

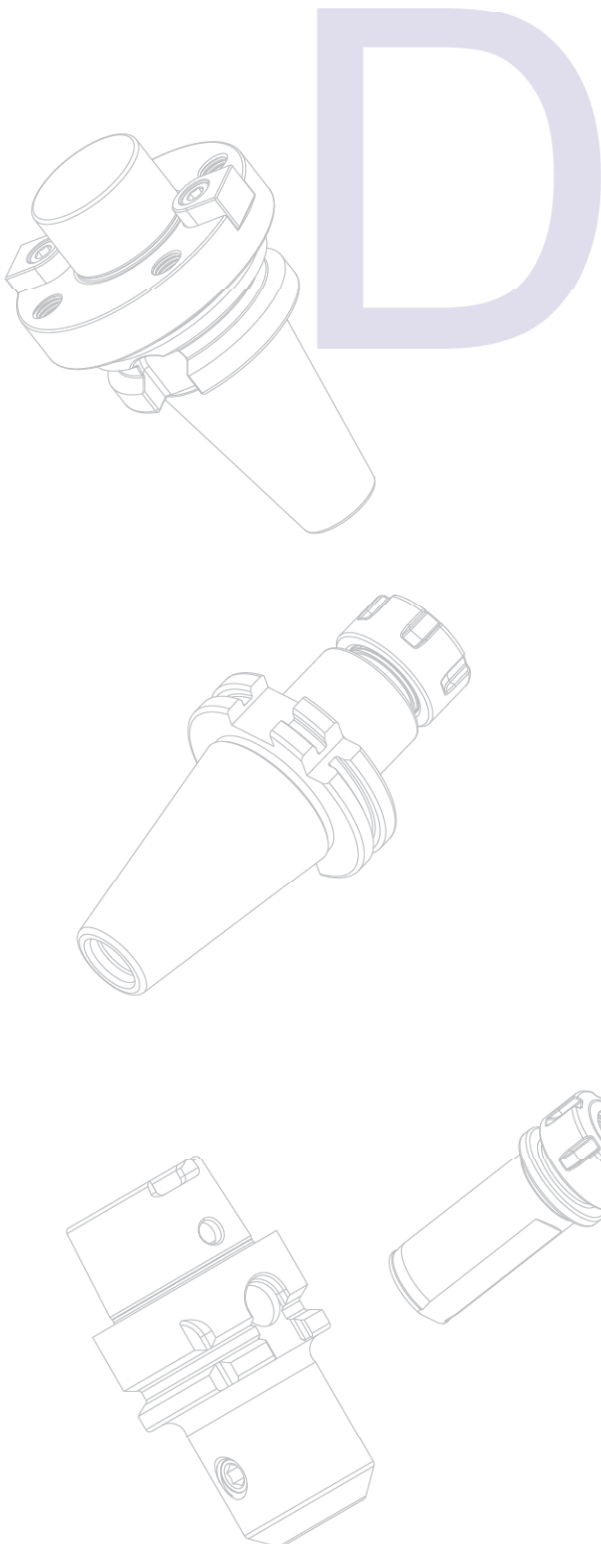

® pod



Shrink Fit Tool System 热胀工具系统

- DIN 69893 HSK-A D009
- DIN 69893 HSK-C/E D013
- JIS B 6339 BT30/40/50 D016
- DIN 69871 JT40/50 D019

HSK Tool System HSK 工具系统

- DIN 69893 HSK-A
- DIN 69893 HSK-C/E/F

TMG21 Tool System TMG21工具系统

- DIN 69893 HSK-A D062
- JIS B 6339 BT30/40/50 D065
- DIN 69871 JT40/50 D069

7:24 Tool System 7:24 工具系统

- JIS B 6339 BT30/40/50
- DIN 69871 JT40/50

Special Tool System 其它工具系统

- DM模块手柄 D133
- ER Collet Extension卡簧接杆 D141
- Morse Taper Shank with Tang有扁尾莫氏圆锥孔变径套 D143

General Accessories 配件

D 工具系统 Tool System

工具系统

SHRINK FIT HOLDER
热胀工具系统

HSK TOOL SYSTEM
HSK工具系统









TMG21 TOOL SYSTEM
TMG21工具系统

7:24 TOOL SYSTEM
7:24工具系统

SPECIAL TOOL SYSTEM
其它工具系统

ACCESSORIES
附件

工具系统产品一览表

	工具系统产品一览表				
	热胀刀柄 标准型 Shrink Fit Holders	热胀刀柄 轻型 Shrink Fit Holders	TMG21 模块主柄 TMG Modular Arbor	GSK 弹簧夹头刀柄 GSK Collet Chucks	
					
	HSK32A	D009			
	HSK40A	D009			
	HSK50A	D009			
	HSK63A	D010	D021	D062	
	HSK80A	D011			
	HSK100A	D012		D063 D064	
	HSK32E	D013			
	HSK40E	D013			
	HSK50E	D014			
	HSK63F	D015			
	BT30	D016	D022	D066	D081
	BT40	D017	D023	D065 D066	D082
	BT50	D018		D067 D068	D083
	JT40	D019		D069 D070	
	JT50	D020		D069 D070	
	莫氏锥柄				
	直柄		D024		

D 工具系统 Tool System

工具系统产品一览表

GSER 弹簧夹头刀柄 GSER Collet Chucks	ER 弹簧夹头刀柄 ER Collet Chucks	液压刀柄 Hydraulic Chucks	强力夹头刀柄 Power Chucks	侧固式刀柄 Side-Locked Holders	2° 侧固式刀柄 2° Side-Locked Holders
					
	D032				
	D032				
	D032				
	D033	D037	D039	D041	
	D034	D038	D040	D042	
	D035				
	D035				
	D035				
	D036				
D084	D087	D092	D094		
D085	D087 D088	D092	D094	D097 D098	D102
D086	D089	D092	D094	D097 D099	D102
	D090	D093	D095	D100	D103
	D091	D093	D095	D101	D103
			D096		

工具系统
 热胀工具系统
 SHRINK FIT HOLDER
 HSK工具系统
 HSK TOOL SYSTEM
 TMG21工具系统
 TMG21 TOOL SYSTEM
 7:24工具系统
 7:24 TOOL SYSTEM
 其它工具系统
 SPECIAL TOOL SYSTEM
 附件
 ACCESSORIES

D 工具系统 Tool System

		工具系统产品一览表			
		面铣刀柄 Shell Mill Holder	套式立铣刀及 三面刃铣刀刀柄 Shell Mill&Disc Mill Holder	三面刃 铣刀刀柄 Disc Cutter Holder	有扁尾 莫氏圆锥孔刀柄 Morse Taper Shank with Tang
					
	HSK32A				
	HSK40A	D043			
	HSK50A				
	HSK63A	D044	D047	D049	D051
	HSK80A				
	HSK100A	D045	D048	D050	D052
	HSK32E				
	HSK40E				
	HSK50E				
	HSK63F	D046			
	BT30	D104			D118
	BT40	D104	D112	D116	D118
	BT50	D105	D113	D116	D118
	JT40	D108	D114	D117	D119
	JT50	D109	D115	D117	D119
	莫氏锥柄				
	直柄				

D 工具系统 Tool System

工具系统产品一览表

无扁尾 莫氏圆锥孔刀柄 Morse Taper Shank without Tang	整体式 钻夹头刀柄 Integral Drill Chucks	变径柄 Adapter Arbor	DM 钢制接杆 Steel Extension For DM Milling Cutters	DM 模块主柄 DM Modular Arbor	DM 硬质合金接杆 Carbide Extension Milling Cutters
					
D053	D055			D137	
D054	D056				
	D122			D135	
D120	D122	D124		D136	
D120	D122	D124			
D121	D123	D124			
D121	D123	D124			
			D134		D138

工具系统
HSK工具系统
HSK TOOL SYSTEM
热胀工具系统
SHRINK FIT HOLDER
7:24工具系统
7:24 TOOL SYSTEM
TMG21工具系统
TMG21 TOOL SYSTEM
其它工具系统
SPECIAL TOOL SYSTEM
附件
ACCESSORIES

D 工具系统 Tool System

热胀工具系统
Shrink Fit Tool System

高刚性
高夹持力
高精度
高动平衡精度



标准型

标准型采用4.5°半角设计，刀体强度高，夹紧力可靠，多用于中、重型加工



结构

结构简单，无需其他配件



轻型

轻型采用3°半角设计，形状细长可尽量避免与工件干涉，可最大限度减小刀具的悬伸，降低加工时振动，进行高刚性稳定的切削。



高精度

跳动精度3um以内
高速动平衡，可实现超精加工铣削

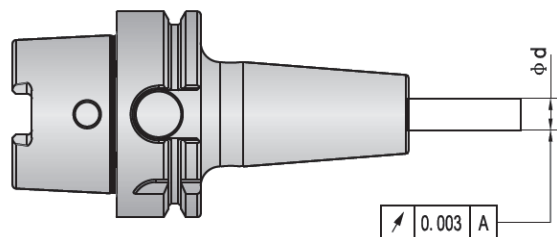

D 工具系统 Tool System

热胀工具系统
Shrink Fit Tool System

历久弥新

高耐久性，同一刀柄经过2000次以上装夹也不会发生精度降低现象。

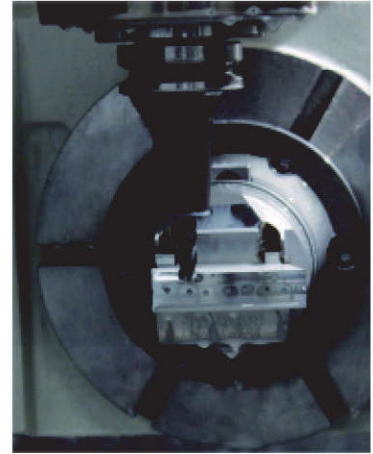

加工方式

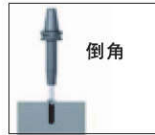
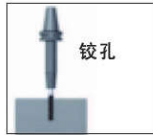

加工方式多样

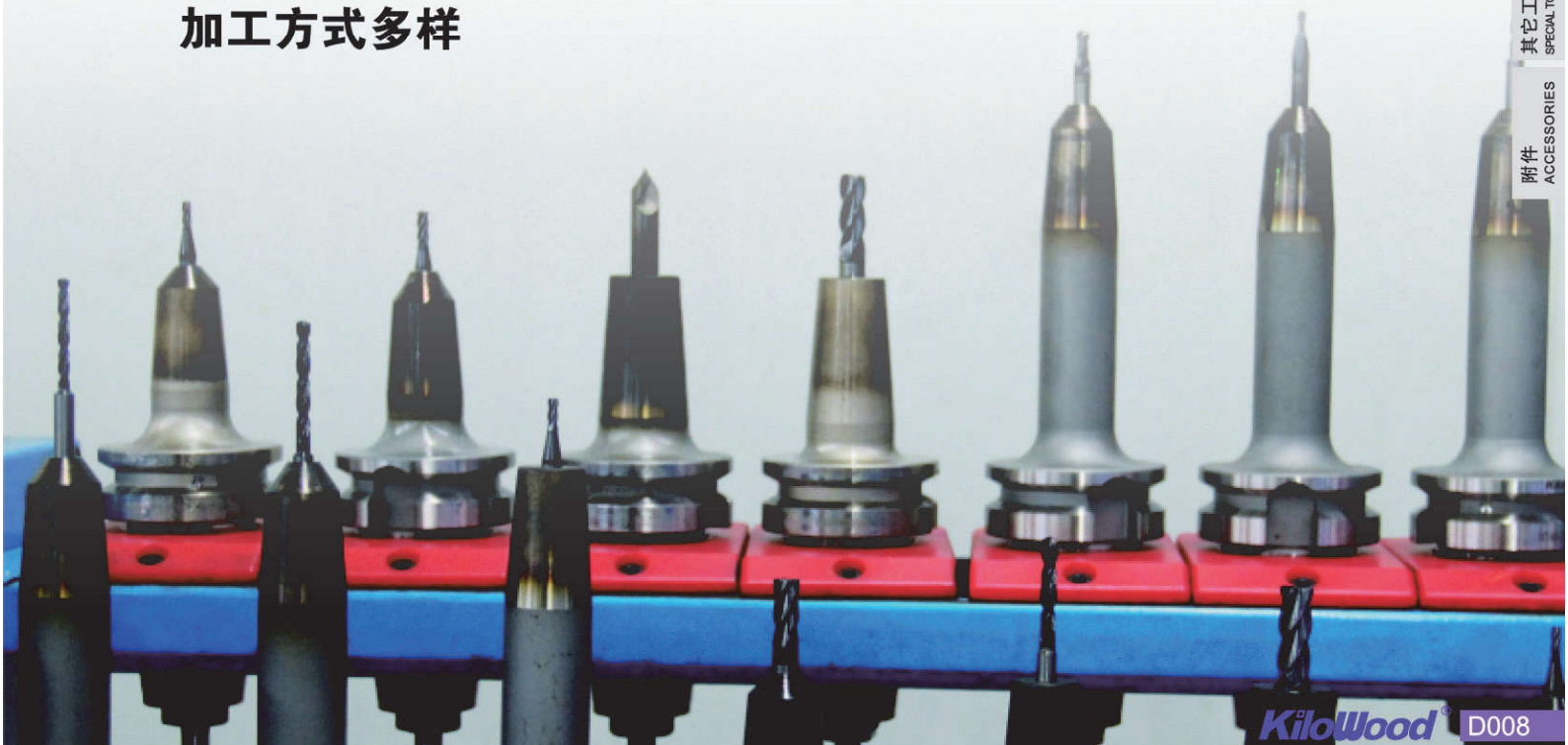

D 工具系统 Tool System

热胀刀柄-HSK32A/HSK40A/HSK50A标准型
Shrink Fit Holders-Standard

DIN 69893
Form A
G2.5 25000/min
 $\lambda = 0.003$
中心冷却
N

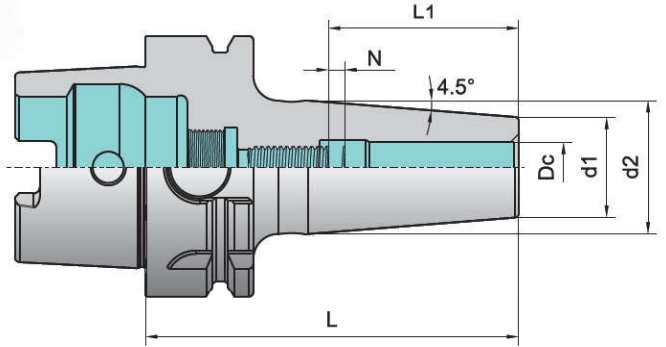

工具系统

SHRINK FIT HOLDER
热胀工具系统

HSK TOOL SYSTEM
HSK工具系统

TMG21 TOOL SYSTEM
TMG21工具系统

7:24 TOOL SYSTEM
7:24工具系统

SPECIAL TOOL SYSTEM
其它工具系统

ACCESSORIES
附件

型号 Type	库存 Stock	锥柄型式 Taper type	尺寸(mm) Dimension						轴向调节螺钉 Axial adjustment screw	重量 (kg)
			Dc	d1	d2	L	L1	N		
HSK32A-TE04-60	●	HSK32A	4	15	20	60	20	-	-	
HSK32A-TE06-70	●	HSK32A	6	21	26	70	36	10	SGC050150	
HSK32A-TE08-70	●	HSK32A	8	21	26	70	36	10	SGC060150	
HSK32A-TE10-80	●	HSK32A	10	24	26	80	40	10	SGC080150	
HSK40A-TE04-60	●	HSK40A	4	15	20	60	20	-	-	
HSK40A-TE06-80	●	HSK40A	6	21	27	80	36	10	SGC050150	
HSK40A-TE08-80	●	HSK40A	8	21	27	80	36	10	SGC060150	
HSK40A-TE10-80	●	HSK40A	10	24	32	80	40	10	SGC080150	
HSK40A-TE12-90	●	HSK40A	12	24	32	90	45	10	SGC100150	
HSK50A-TE04-60	●	HSK50A	4	15	20	60	20	-	-	
HSK50A-TE06-80	●	HSK50A	6	21	27	80	36	10	SGC050150	
HSK50A-TE08-80	●	HSK50A	8	21	27	80	36	10	SGC060150	
HSK50A-TE10-85	●	HSK50A	10	24	32	85	40	10	SGC080150	
HSK50A-TE12-90	●	HSK50A	12	24	32	90	45	10	SGC100150	
HSK50A-TE16-95	●	HSK50A	16	27	34	95	48	10	SGC120200	

订货示例:HSK32A-TE04-60 G2.5 25000rpm

● 常备库存 Unallocated stock
● 可备库存 Available stock
○ 订单生产 Order production

D 工具系统 Tool System

热胀刀柄-HSK63A标准型
Shrink Fit Holders-Standard

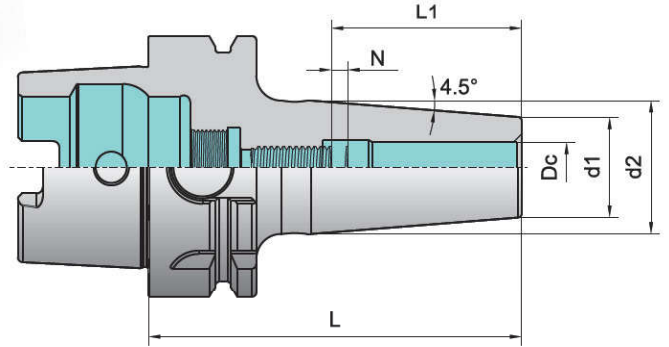

型号 Type	库存 Stock	锥柄型式 Taper type	尺寸(mm) Dimension						轴向调节螺钉 Axial adjustment screw	重量 (kg)
			Dc	d1	d2	L	L1	N		
HSK63A-TE04-80	●	HSK63A	4	15	20	80	20	-	-	
HSK63A-TE06-80	●	HSK63A	6	21	27	80	36	10	SGC050150	
-120	●	HSK63A	6	21	27	120	36	10	SGC050150	
-160	●	HSK63A	6	21	27	160	36	10	SGC050150	
HSK63A-TE08-80	●	HSK63A	8	21	27	80	36	10	SGC060150	
-120	●	HSK63A	8	21	27	120	36	10	SGC060150	
-160	●	HSK63A	8	21	27	160	36	10	SGC060150	
HSK63A-TE10-85	●	HSK63A	10	24	32	85	40	10	SGC080150	
-120	●	HSK63A	10	24	32	120	40	10	SGC080150	
-160	●	HSK63A	10	24	32	160	40	10	SGC080150	
HSK63A-TE12-90	●	HSK63A	12	24	32	90	45	10	SGC100150	
-120	●	HSK63A	12	24	32	120	45	10	SGC100150	
-160	●	HSK63A	12	24	32	160	45	10	SGC100150	
HSK63A-TE16-95	●	HSK63A	16	27	34	95	48	10	SGC120200	
-120	●	HSK63A	16	27	34	120	48	10	SGC120200	
-160	●	HSK63A	16	27	34	160	48	10	SGC120200	
HSK63A-TE20-100	●	HSK63A	20	33	42	100	50	10	SGC160200	
-120	●	HSK63A	20	33	42	120	50	10	SGC160200	
-160	●	HSK63A	20	33	42	160	50	10	SGC160200	
HSK63A-TE25-115	●	HSK63A	25	44	53	115	56	10	SGD220250	
-160	●	HSK63A	25	44	53	160	56	10	SGD220250	
HSK63A-TE32-120	●	HSK63A	32	44	53	120	60	10	SGD280250	
-160	●	HSK63A	32	44	53	160	60	10	SGD280250	

订货示例:HSK63A-TE04-80 G2.5 25000rpm

● 常备库存 Unallocated stock ● 可备库存 Available stock ○ 订单生产 Order production

D 工具系统 Tool System

热胀刀柄-HSK80A标准型
Shrink Fit Holders-Standard

DIN 69893
Form A
G2.5 20000/min
 $\lambda = 0.003$
中心冷却
N

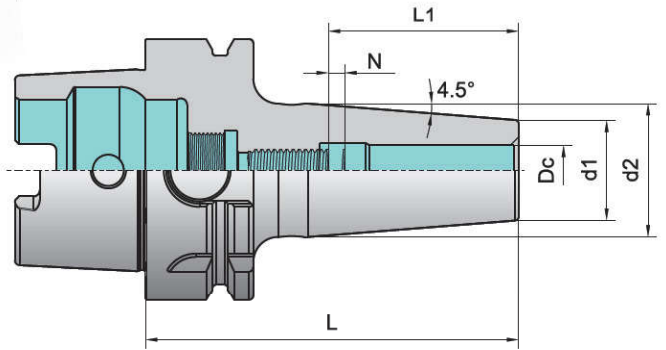

工具系统

SHRINK FIT HOLDER
热胀工具系统

HSK TOOL SYSTEM
HSK工具系统

TMG21 TOOL SYSTEM
TMG21工具系统

7:24 TOOL SYSTEM
7:24工具系统

SPECIAL TOOL SYSTEM
其它工具系统

ACCESSORIES
附件

型号 Type	库存 Stock	锥柄型式 Taper type	尺寸(mm) Dimension						轴向调节螺钉 Axial adjustment screw	重量 (kg)
			Dc	d1	d2	L	L1	N		
HSK80A-TE06-85	○	HSK80A	6	21	27	85	36	10	SGC050150	
HSK80A-TE08-85	○	HSK80A	8	21	27	85	36	10	SGC060150	
HSK80A-TE10-90	○	HSK80A	10	24	32	90	40	10	SGC080150	
HSK80A-TE12-95	○	HSK80A	12	24	32	95	45	10	SGC100150	
HSK80A-TE16-100	○	HSK80A	16	27	34	100	48	10	SGC120200	
HSK80A-TE20-105	○	HSK80A	20	33	42	105	50	10	SGC160200	
HSK80A-TE25-115	○	HSK80A	25	44	53	115	56	10	SGD220250	
HSK80A-TE32-120	○	HSK80A	32	44	53	120	60	10	SGD280250	

订货示例: HSK80A-TE06-85 G2.5 20000rpm

- 常备库存 Unallocated stock
- ◐ 可备库存 Available stock
- 订单生产 Order production

D 工具系统 Tool System

热胀刀柄-HSK100A标准型
Shrink Fit Holders-Standard

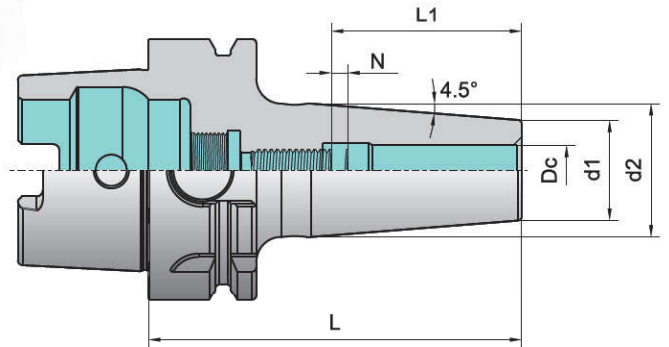

型号 Type	库存 Stock	锥柄型式 Taper type	尺寸(mm) Dimension						轴向调节螺钉 Axial adjustment screw	重量 (kg)
			Dc	d1	d2	L	L1	N		
HSK100A-TE06-85	●	HSK100A	6	21	27	85	36	10	SGC050150	
-120	●	HSK100A	6	21	27	120	36	10	SGC050150	
-160	●	HSK100A	6	21	27	160	36	10	SGC050150	
HSK100A-TE08-85	●	HSK100A	8	21	27	85	36	10	SGC060150	
-120	●	HSK100A	8	21	27	120	36	10	SGC060150	
-160	●	HSK100A	8	21	27	160	36	10	SGC060150	
HSK100A-TE10-90	●	HSK100A	10	24	32	90	40	10	SGC080150	
-120	●	HSK100A	10	24	32	120	40	10	SGC080150	
-160	●	HSK100A	10	24	32	160	40	10	SGC080150	
HSK100A-TE12-95	●	HSK100A	12	24	32	95	45	10	SGC100150	
-120	●	HSK100A	12	24	32	120	45	10	SGC100150	
-160	●	HSK100A	12	24	32	160	45	10	SGC100150	
HSK100A-TE16-100	●	HSK100A	16	27	34	100	48	10	SGC120200	
-160	●	HSK100A	16	27	34	160	48	10	SGC120200	
HSK100A-TE20-105	●	HSK100A	20	33	42	105	50	10	SGC160200	
-160	●	HSK100A	20	33	42	160	50	10	SGC160200	
HSK100A-TE25-115	●	HSK100A	25	44	53	115	56	10	SGD220250	
-160	●	HSK100A	25	44	53	160	56	10	SGD220250	
HSK100A-TE32-120	●	HSK100A	32	44	53	120	60	10	SGD280250	
-160	●	HSK100A	32	44	53	160	60	10	SGD280250	

订货示例:HSK100A-TE06-85 G2.5 15000rpm

● 常备库存 Unallocated stock ● 可备库存 Available stock ○ 订单生产 Order production

D 工具系统 Tool System

热胀刀柄-HSK32E/HSK40E标准型
Shrink Fit Holders-Standard

DIN 69893
Form E
G2.5 25000/min
 $\lambda = 0.003$
中心冷却
N

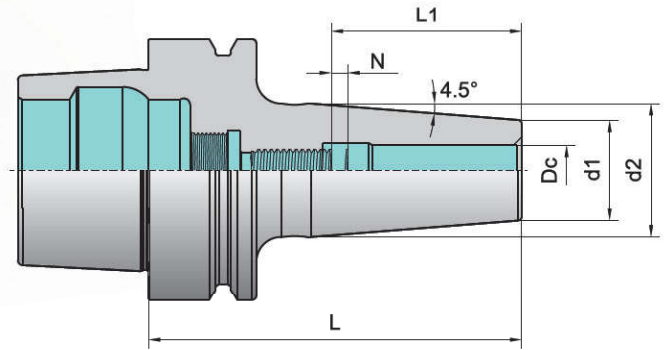

工具系统

SHRINK FIT HOLDER
热胀工具系统

HSK TOOL SYSTEM
HSK工具系统

TMG21 TOOL SYSTEM
TMG21工具系统

7:24 TOOL SYSTEM
7:24工具系统

SPECIAL TOOL SYSTEM
其它工具系统

ACCESSORIES
附件

型号 Type	库存 Stock	锥柄型式 Taper type	尺寸(mm) Dimension						轴向调节螺钉 Axial adjustment screw	重量 (kg)
			Dc	d1	d2	L	L1	N		
HSK32E-TE04-60	●	HSK32E	4	15	20	60	20	-	-	
HSK32E-TE06-70	●	HSK32E	6	21	27	70	36	10	SGC050150	
HSK32E-TE08-70	●	HSK32E	8	21	27	70	36	10	SGC060150	
HSK32E-TE10-80	●	HSK32E	10	24	32	80	40	10	SGC080150	
HSK40E-TE04-60	●	HSK40E	4	15	20	60	20	-	-	
HSK40E-TE06-60	●	HSK40E	6	21	27	60	36	10	SGC050150	
-80	●	HSK40E	6	21	27	80	36	10	SGC050150	
HSK40E-TE08-60	●	HSK40E	8	21	27	60	36	10	SGC060150	
-80	●	HSK40E	8	21	27	80	36	10	SGC060150	
HSK40E-TE10-60	●	HSK40E	10	24	32	60	40	10	SGC080150	
-90	●	HSK40E	10	24	32	90	40	10	SGC080150	
HSK40E-TE12-60	●	HSK40E	12	24	32	60	45	10	SGC100150	
-90	●	HSK40E	12	24	32	90	45	10	SGC100150	

订货示例:HSK32E-TE04-60 G2.5 25000rpm

● 常备库存 Unallocated stock
● 可备库存 Available stock
○ 订单生产 Order production

D 工具系统 Tool System

热胀刀柄-HSK50E标准型
Shrink Fit Holders-Standard

DIN 69893
Form E
G2.5 25000/min
 $\lambda = 0.003$
中心冷却
N

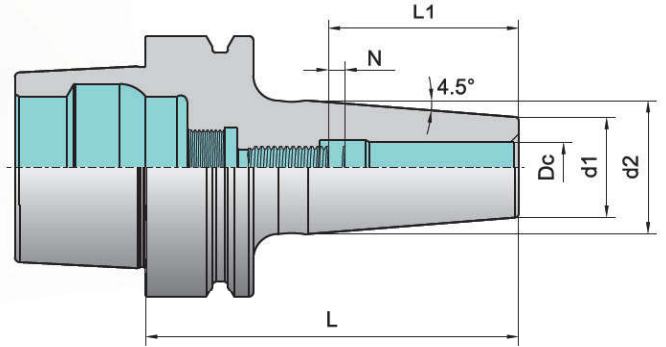

型号 Type	库存 Stock	锥柄型式 Taper type	尺寸(mm) Dimension						轴向调节螺钉 Axial adjustment screw	重量 (kg)
			Dc	d1	d2	L	L1	N		
HSK50E-TE04-60	●	HSK50E	4	15	20	60	20	-	-	
HSK50E-TE06-80	●	HSK50E	6	21	27	80	36	10	SGC050150	
HSK50E-TE08-80	●	HSK50E	8	21	27	80	36	10	SGC060150	
HSK50E-TE10-85	●	HSK50E	10	24	32	85	40	10	SGC080150	
HSK50E-TE12-90	●	HSK50E	12	24	32	90	45	10	SGC100150	
HSK50E-TE16-95	●	HSK50E	16	27	34	95	48	10	SGC120200	

订货示例:HSK50E-TE04-60 G2.5 25000rpm

● 常备库存 Unallocated stock
● 可备库存 Available stock
○ 订单生产 Order production

工具系统
 热胀工具系统 SHRINK FIT HOLDER
 HSK工具系统 HSK TOOL SYSTEM
 TMG21工具系统 TMG21 TOOL SYSTEM
 7:24工具系统 7:24 TOOL SYSTEM
 其它工具系统 SPECIAL TOOL SYSTEM
 附件 ACCESSORIES

D 工具系统 Tool System

热胀刀柄-HSK63F标准型
Shrink Fit Holders-Standard

DIN 69893
Form F
G2.5 25000/min
 $\lambda = 0.003$
中心冷却
N

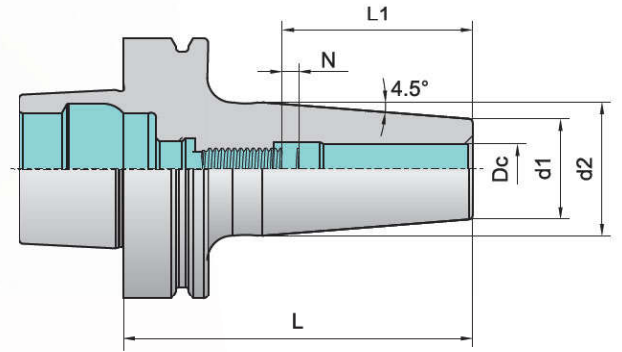

工具系统

SHRINK FIT HOLDER
热胀工具系统

HSK TOOL SYSTEM
HSK工具系统

TMG21 TOOL SYSTEM
TMG21工具系统

7:24 TOOL SYSTEM
7:24工具系统

SPECIAL TOOL SYSTEM
其它工具系统

ACCESSORIES
附件

型号 Type	库存 Stock	锥柄型式 Taper type	尺寸(mm) Dimension						轴向调节螺钉 Axial adjustment screw	重量 (kg)
			Dc	d1	d2	L	L1	N		
HSK63F-TE04-80	●	HSK63F	4	15	20	80	20	-	-	
HSK63F-TE06-80	●	HSK63F	6	21	27	80	36	10	SGC050150	
HSK63F-TE08-80	●	HSK63F	8	21	27	80	36	10	SGC060150	
HSK63F-TE10-85	●	HSK63F	10	24	32	85	40	10	SGC080150	
HSK63F-TE12-90	●	HSK63F	12	24	32	90	45	10	SGC100150	
HSK63F-TE16-95	●	HSK63F	16	27	34	95	48	10	SGC120200	
HSK63F-TE20-100	●	HSK63F	20	33	42	100	50	10	SGC160200	

订货示例: HSK63F-TE04-80 G2.5 25000rpm

● 常备库存 Unallocated stock
● 可备库存 Available stock
○ 订单生产 Order production

D 工具系统 Tool System

热胀刀柄-BT30标准型
Shrink Fit Holders-Standard

JIS B 6339
G2.5 25000/min
 $\lambda = 0.003$
中心冷却
N

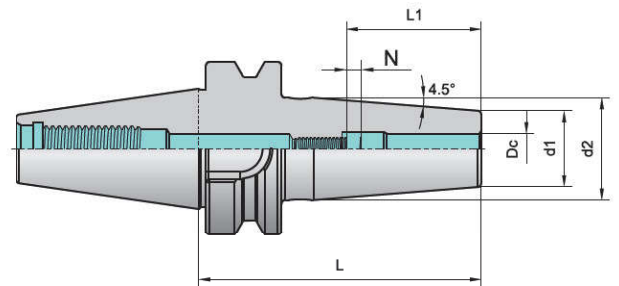

型号 Type	库存 Stock	锥柄型式 Taper type	尺寸(mm) Dimension						轴向调节螺钉 Axial adjustment screw	重量 (kg)
			Dc	d1	d2	L	L1	N		
BT30-TE04-60	●	BT30	4	15	20	60	20	-	-	
BT30-TE06-80	●	BT30	6	21	27	80	36	10	SGC050150	
BT30-TE08-80	●	BT30	8	21	27	80	36	10	SGC060150	
BT30-TE10-80	●	BT30	10	24	32	80	40	10	SGC080150	
BT30-TE12-80	●	BT30	12	24	32	80	45	10	SGC100150	
BT30-TE16-80	◐	BT30	16	27	34	80	48	10	SGC120200	

订货示例:BT30-TE04-60 G2.5 25000rpm

● 常备库存 Unallocated stock
◐ 可备库存 Available stock
○ 订单生产 Order production

工具系统
 热胀工具系统 SHRINK FIT HOLDER
 HSK工具系统 HSK TOOL SYSTEM
 TMG21工具系统 TMG21 TOOL SYSTEM
 7:24工具系统 7:24 TOOL SYSTEM
 其它工具系统 SPECIAL TOOL SYSTEM
 附件 ACCESSORIES

D 工具系统 Tool System

热胀刀柄-BT40标准型
Shrink Fit Holders-Standard

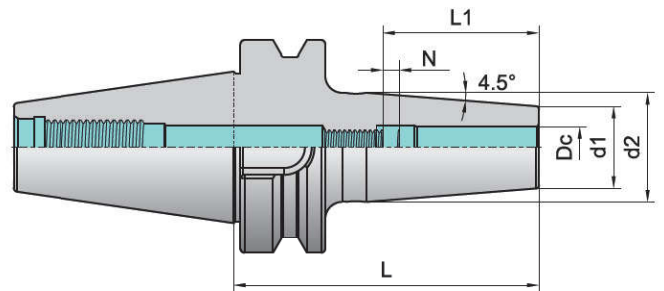
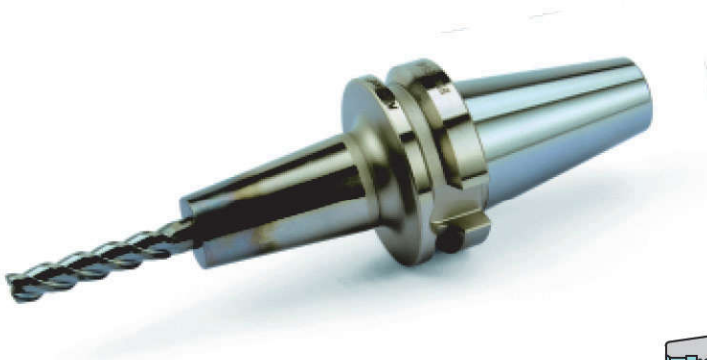
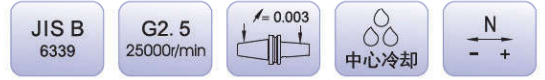

工具系统

SHRINK FIT HOLDER
热胀工具系统

HSK TOOL SYSTEM
HSK工具系统

TMG21 TOOL SYSTEM
TMG21工具系统

7:24 TOOL SYSTEM
7:24工具系统

SPECIAL TOOL SYSTEM
其它工具系统

ACCESSORIES
附件

型号 Type	库存 Stock	锥柄型式 Taper type	尺寸(mm) Dimension						轴向调节螺钉 Axial adjustment screw	重量 (kg)
			Dc	d1	d2	L	L1	N		
BT40-TE04-90	●	BT40	4	15	20	90	20	-	-	
BT40-TE06-90	●	BT40	6	21	27	90	36	10	SGC050150	
-120	◐	BT40	6	21	27	120	36	10	SGC050150	
-160	◑	BT40	6	21	27	160	36	10	SGC050150	
BT40-TE08-90	●	BT40	8	21	27	90	36	10	SGC060150	
-120	◐	BT40	8	21	27	120	36	10	SGC060150	
-160	◑	BT40	8	21	27	160	36	10	SGC060150	
BT40-TE10-90	●	BT40	10	24	32	90	40	10	SGC080150	
-120	◐	BT40	10	24	32	120	40	10	SGC080150	
-160	◑	BT40	10	24	32	160	40	10	SGC080150	
BT40-TE12-90	●	BT40	12	24	32	90	45	10	SGC100150	
-120	◐	BT40	12	24	32	120	45	10	SGC100150	
-160	◑	BT40	12	24	32	160	45	10	SGC100150	
BT40-TE16-90	●	BT40	16	27	34	90	48	10	SGC120200	
-120	◐	BT40	16	27	34	120	48	10	SGC120200	
-160	◑	BT40	16	27	34	160	48	10	SGC120200	
BT40-TE20-90	◐	BT40	20	33	42	90	50	10	SGC160200	
-120	◑	BT40	20	33	42	120	50	10	SGC160200	
-160	◒	BT40	20	33	42	160	50	10	SGC160200	
BT40-TE25-100	◐	BT40	25	44	53	100	56	10	SGD220250	
-160	◑	BT40	25	44	53	160	56	10	SGD220250	
BT40-TE32-100	◐	BT40	32	44	53	100	60	10	SGD280250	
-160	◑	BT40	32	44	53	160	60	10	SGD280250	

订货示例:BT40-TE04-90 G2.5 25000rpm

● 常备库存 Unallocated stock ◐ 可备库存 Available stock ◑ 订单生产 Order production

D 工具系统 Tool System

热胀刀柄-BT50标准型
Shrink Fit Holders-Standard

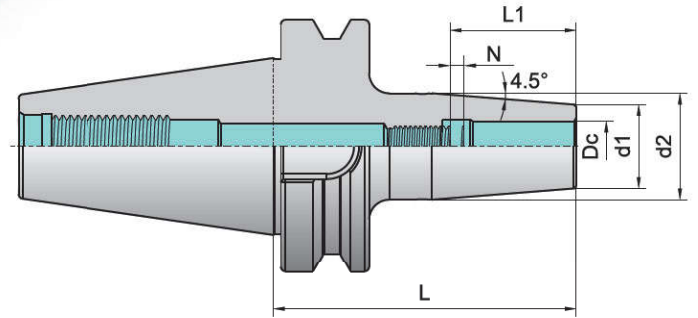
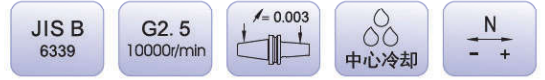

型号 Type	库存 Stock	锥柄型式 Taper type	尺寸(mm) Dimension						轴向调节螺钉 Axial adjustment screw 	重量 (kg)
			Dc	d1	d2	L	L1	N		
BT50-TE06-100	●	BT50	6	21	27	100	36	10	SGC050150	
-160	●	BT50	6	21	27	160	36	10	SGC050150	
BT50-TE08-100	●	BT50	8	21	27	100	36	10	SGC060150	
-160	●	BT50	8	21	27	160	36	10	SGC060150	
BT50-TE10-100	●	BT50	10	24	32	100	45	10	SGC080150	
-160	●	BT50	10	24	32	160	45	10	SGC080150	
BT50-TE12-100	●	BT50	12	24	32	100	45	10	SGC100150	
-160	●	BT50	12	24	32	160	45	10	SGC100150	
BT50-TE16-100	●	BT50	16	27	34	100	48	10	SGC120200	
-160	●	BT50	16	27	34	160	48	10	SGC120200	
BT50-TE20-100	●	BT50	20	33	42	100	50	10	SGC160200	
-160	●	BT50	20	33	42	160	50	10	SGC160200	
BT50-TE25-100	●	BT50	25	44	53	100	56	10	SGD220250	
-160	●	BT50	25	44	53	160	56	10	SGD220250	
BT50-TE32-100	●	BT50	32	44	53	100	60	10	SGD280250	
-160	●	BT50	32	44	53	160	60	10	SGD280250	

订货示例:BT50-TE06-100 G2.5 10000rpm

● 常备库存 Unallocated stock ● 可备库存 Available stock ○ 订单生产 Order production

D 工具系统 Tool System

热胀刀柄-JT40标准型
Shrink Fit Holders-Standard

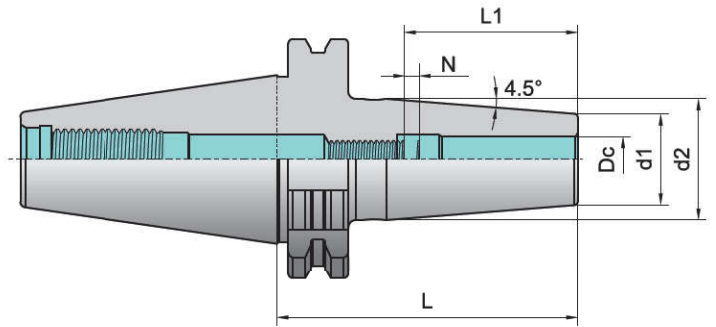
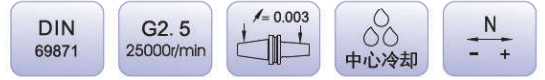

型号 Type	库存 Stock	锥柄型式 Taper type	尺寸(mm) Dimension						轴向调节螺钉 Axial adjustment screw	重量 (kg)
			Dc	d1	d2	L	L1	N		
JT40-TE04-80	●	JT40	4	15	20	80	20	-	-	
JT40-TE06-80	●	JT40	6	21	27	80	36	10	SGC050150	
-120	●	JT40	6	21	27	120	36	10	SGC050150	
-160	●	JT40	6	21	27	160	36	10	SGC050150	
JT40-TE08-80	●	JT40	8	21	27	80	36	10	SGC060150	
-120	●	JT40	8	21	27	120	36	10	SGC060150	
-160	●	JT40	8	21	27	160	36	10	SGC060150	
JT40-TE10-80	●	JT40	10	24	32	80	40	10	SGC080150	
-120	●	JT40	10	24	32	120	40	10	SGC080150	
-160	●	JT40	10	24	32	160	40	10	SGC080150	
JT40-TE12-80	●	JT40	12	24	32	80	45	10	SGC100150	
-120	●	JT40	12	24	32	120	45	10	SGC100150	
-160	●	JT40	12	24	32	160	45	10	SGC100150	
JT40-TE16-80	●	JT40	16	27	34	80	48	10	SGC120200	
-120	●	JT40	16	27	34	120	48	10	SGC120200	
-160	●	JT40	16	27	34	160	48	10	SGC120200	
JT40-TE20-80	●	JT40	20	33	42	80	50	10	SGC160200	
-120	●	JT40	20	33	42	120	50	10	SGC160200	
-160	●	JT40	20	33	42	160	50	10	SGC160200	
JT40-TE25-100	●	JT40	25	44	53	100	56	10	SGD220250	
-160	●	JT40	25	44	53	160	56	10	SGD220250	
JT40-TE32-100	●	JT40	32	44	53	100	60	10	SGD280250	
-160	●	JT40	32	44	53	160	60	10	SGD280250	

订货示例: JT40-TE04-80 G2.5 25000rpm

● 常备库存 Unallocated stock ● 可备库存 Available stock ○ 订单生产 Order production

D 工具系统 Tool System

热胀刀柄-JT50标准型
Shrink Fit Holders-Standard

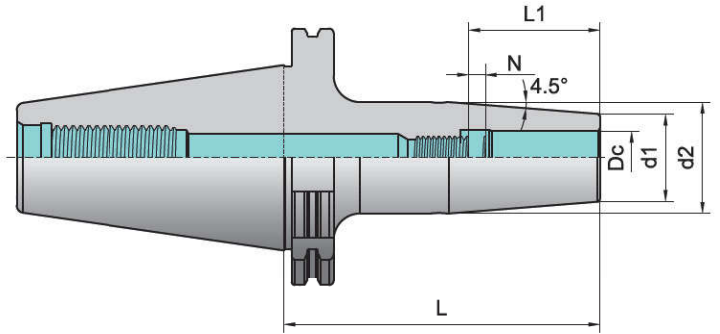
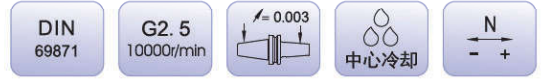

型号 Type	库存 Stock	锥柄型式 Taper type	尺寸(mm) Dimension						轴向调节螺钉 Axial adjustment screw	重量 (kg)
			Dc	d1	d2	L	L1	N		
JT50-TE06-80	●	JT50	6	21	27	80	36	10	SGC050150	
-120	●	JT50	6	21	27	120	36	10	SGC050150	
-160	●	JT50	6	21	27	160	36	10	SGC050150	
JT50-TE08-80	●	JT50	8	21	27	80	36	10	SGC060150	
-120	●	JT50	8	21	27	120	36	10	SGC060150	
-160	●	JT50	8	21	27	160	36	10	SGC060150	
JT50-TE10-80	●	JT50	10	24	32	80	40	10	SGC080150	
-120	●	JT50	10	24	32	120	40	10	SGC080150	
-160	●	JT50	10	24	32	160	40	10	SGC080150	
JT50-TE12-80	●	JT50	12	24	32	80	45	10	SGC100150	
-120	●	JT50	12	24	32	120	45	10	SGC100150	
-160	●	JT50	12	24	32	160	45	10	SGC100150	
JT50-TE16-80	●	JT50	16	27	34	80	48	10	SGC120200	
-120	●	JT50	16	27	34	120	48	10	SGC120200	
-160	●	JT50	16	27	34	160	48	10	SGC120200	
JT50-TE20-80	●	JT50	20	33	42	80	50	10	SGC160200	
-120	●	JT50	20	33	42	120	50	10	SGC160200	
-160	●	JT50	20	33	42	160	50	10	SGC160200	
JT50-TE25-100	●	JT50	25	44	53	100	56	10	SGD220250	
-160	●	JT50	25	44	53	160	56	10	SGD220250	
JT50-TE32-100	●	JT50	32	44	53	100	60	10	SGD280250	
-160	●	JT50	32	44	53	160	60	10	SGD280250	

订货示例:JT50-TE06-80 G2.5 10000rpm

● 常备库存 Unallocated stock ● 可备库存 Available stock ○ 订单生产 Order production

D 工具系统 Tool System

热胀刀柄-HSK63A轻型 Shrink Fit Holders-Slim

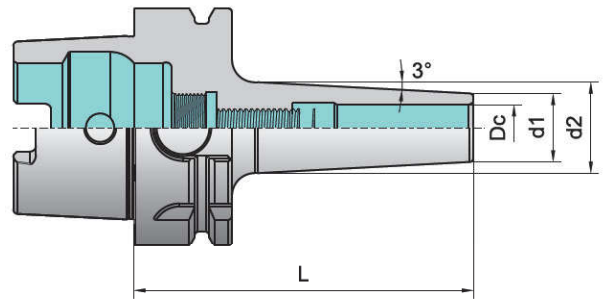

工具系统

SHRINK FIT HOLDER
热胀工具系统

HSK TOOL SYSTEM
HSK工具系统

TMG21 TOOL SYSTEM
TMG21工具系统

7:24 TOOL SYSTEM
7:24工具系统

SPECIAL TOOL SYSTEM
其它工具系统

ACCESSORIES
附件

型号 Type	库存 Stock	锥柄型式 Taper type	尺寸(mm) Dimension				轴向调节螺钉 Axial adjustment screw	重量 (kg)
			Dc	d1	d2	L		
HSK63A-TES04-80	●	HSK63A	4	10	16	80	-	
-120	●	HSK63A	4	10	19	120	-	
-160	●	HSK63A	4	10	22	160	-	
HSK63A-TES06-80	●	HSK63A	6	12	18	80	SGC050150	
-120	●	HSK63A	6	12	21	120	SGC050150	
-160	●	HSK63A	6	12	24	160	SGC050150	
HSK63A-TES08-80	●	HSK63A	8	14	20	80	SGC060150	
-120	●	HSK63A	8	14	23	120	SGC060150	
-160	●	HSK63A	8	14	26	160	SGC060150	
HSK63A-TES10-85	●	HSK63A	10	16	22	85	SGC080150	
-120	●	HSK63A	10	16	25	120	SGC080150	
-160	●	HSK63A	10	16	28	160	SGC080150	
HSK63A-TES12-90	●	HSK63A	12	18	24	90	SGC100150	
-120	●	HSK63A	12	18	27	120	SGC100150	
-160	●	HSK63A	12	18	30	160	SGC100150	

订货示例: HSK63A-TES04-90 C2.5 25000rpm

● 常备库存
Unallocated stock

● 可备库存
Available stock

○ 订单生产
Order production

D 工具系统 Tool System

热胀刀柄-BT30轻型
Shrink Fit Holders-Slim

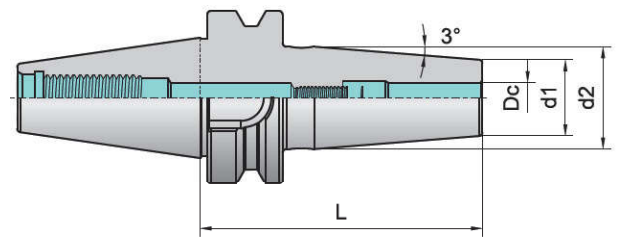
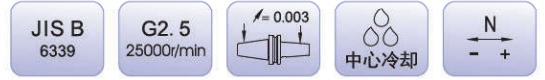

型号 Type	库存 Stock	锥柄型式 Taper type	尺寸(mm) Dimension				轴向调节螺钉 Axial adjustment screw	重量 (kg)
			Dc	d1	d2	L		
BT30-TES03-60	●	BT30	3	8	14	60	-	
BT30-TES04-60	●	BT30	4	10	16	60	-	
BT30-TES06-80	●	BT30	6	12	18	80	SGC050150	
BT30-TES08-80	●	BT30	8	14	20	80	SGC060150	
BT30-TES10-80	●	BT30	10	16	22	80	SGC080150	
BT30-TES12-80	●	BT30	12	18	24	80	SGC100150	

订货示例:BT30-TES03-80 G2.5 25000rpm

● 常备库存 Unallocated stock ◐ 可备库存 Available stock ○ 订单生产 Order production

工具系统
热胀工具系统 SHRINK FIT HOLDER
HSK工具系统 HSK TOOL SYSTEM
TMG21工具系统 TMG21 TOOL SYSTEM
7:24工具系统 7:24 TOOL SYSTEM
其它工具系统 SPECIAL TOOL SYSTEM
附件 ACCESSORIES

D 工具系统 Tool System

热胀刀柄-BT40轻型 Shrink Fit Holders-Slim

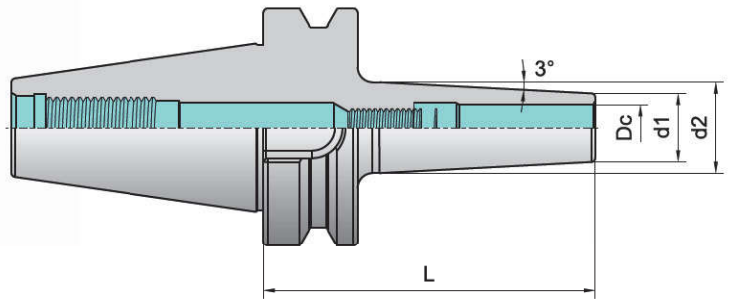
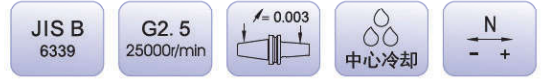

工具系统

SHRINK FIT HOLDER
热胀工具系统

HSK TOOL SYSTEM
HSK工具系统

TMG21 TOOL SYSTEM
TMG21工具系统

7:24 TOOL SYSTEM
7:24工具系统

SPECIAL TOOL SYSTEM
其它工具系统

ACCESSORIES
附件

型号 Type	库存 Stock	锥柄型式 Taper type	尺寸(mm) Dimension				轴向调节螺钉 Axial adjustment screw	重量 (kg)
			Dc	d1	d2	L		
BT40-TES04-90	●	BT40	4	10	16	90	-	
-120	●	BT40	4	10	19	120	-	
-160	●	BT40	4	10	22	160	-	
BT40-TES06-90	●	BT40	6	12	18	90	SGC050150	
-120	●	BT40	6	12	21	120	SGC050150	
-160	●	BT40	6	12	24	160	SGC050150	
BT40-TES08-90	●	BT40	8	14	20	90	SGC060150	
-120	●	BT40	8	14	23	120	SGC060150	
-160	●	BT40	8	14	26	160	SGC060150	
BT40-TES10-90	●	BT40	10	16	22	90	SGC080150	
-120	●	BT40	10	16	25	120	SGC080150	
-160	●	BT40	10	16	28	160	SGC080150	
BT40-TES12-90	●	BT40	12	18	24	90	SGC100150	
-120	●	BT40	12	18	27	120	SGC100150	
-160	●	BT40	12	18	30	160	SGC100150	

订货示例:BT40-TES04-90 G2.5 25000rpm

● 常备库存
Unallocated stock

● 可备库存
Available stock

○ 订单生产
Order production

D 工具系统 Tool System

迷你型-热胀延长杆
Shrink Fit Extension Bar

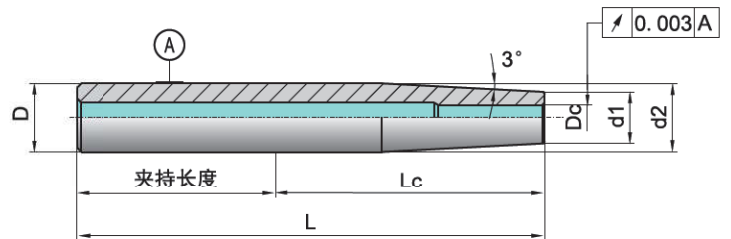

型号 Type	库存 Stock	尺寸(mm) Dimension						重量 (kg)
		D	Dc	d1	d2	Lc	L	
A12-TES04-110	●	12	4	10	11.8	63	110	0.08
A16-TES04-110	●	16	4	10	14	60	110	0.13
-200	●	16	4	10	16	150	200	0.27
A16-TES06-110	●	16	6	12	15.8	60	110	0.14
-200	●	16	6	12	16	150	200	0.26
A20-TES04-110	●	20	4	10	14	58	110	0.18
A20-TES06-110	●	20	6	12	16	58	110	0.18
-250	●	20	6	12	20	198	250	0.50
A20-TES08-110	●	20	8	14	19	58	110	0.19
-250	●	20	8	14	20	198	250	0.48
A20-TES10-110	●	20	10	16	19.8	58	110	0.19
-250	●	20	10	16	20	198	250	0.45
A20-TES12-110	●	20	12	18	19.8	58	110	0.17
A25-TES12-250	●	25	12	18	25	193	250	0.68
A25-TES16-250	●	25	16	22	25	193	250	0.56





订货示例:A12-TES04-110

● 常备库存 Unallocated stock ● 可备库存 Available stock ○ 订单生产 Order production

D 工具系统 Tool System

热胀延长杆叠套示意图
Shrink Fit Extension Bar Diagram

提供以下接口的热胀刀柄

				
BT	CAT	JT	ST	HSK
JIS B6339	ANSI B5.50	DIN69871	DIN2080	DIN69893

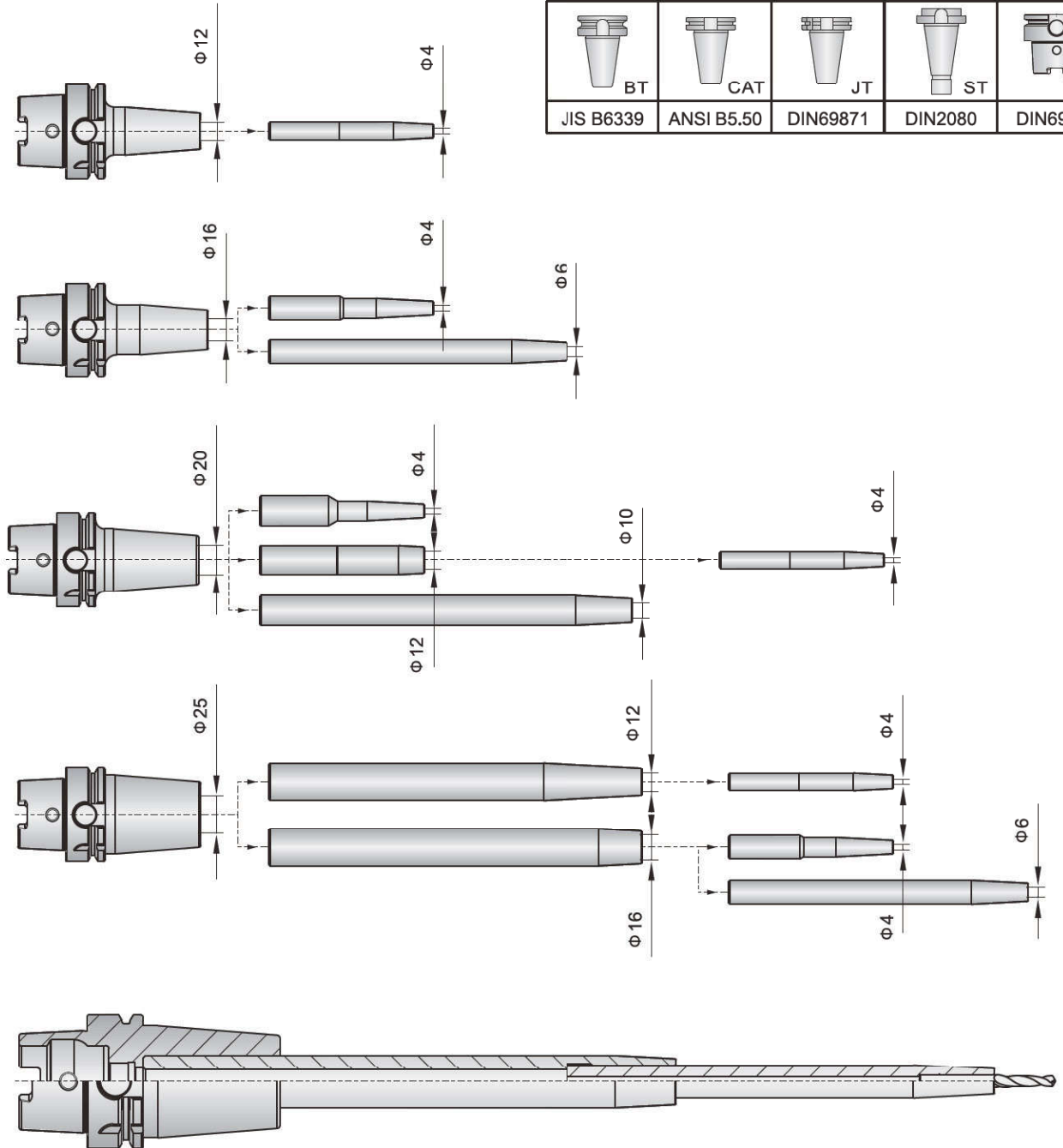

D 工具系统 Tool System

工具系统

SHRINK FIT HOLDER
热胀工具系统

HSK TOOL SYSTEM
HSK工具系统

TMG21 TOOL SYSTEM
TMG21工具系统

7:24 TOOL SYSTEM
7:24工具系统

SPECIAL TOOL SYSTEM
其它工具系统

ACCESSORIES
附件



D 工具系统 Tool System

技术资料
Technical Data

HSK锥柄结构

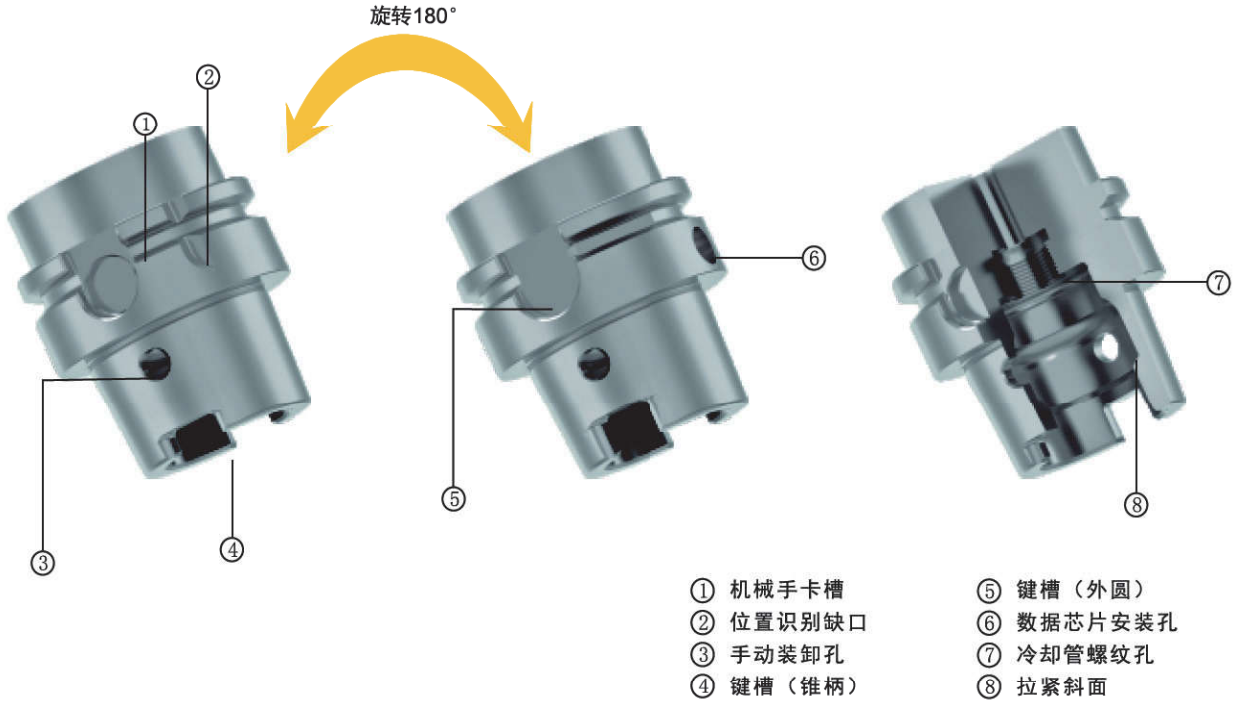

HSK刀柄与主轴的连接结构及工作原理

图一 拉杆未拉紧前

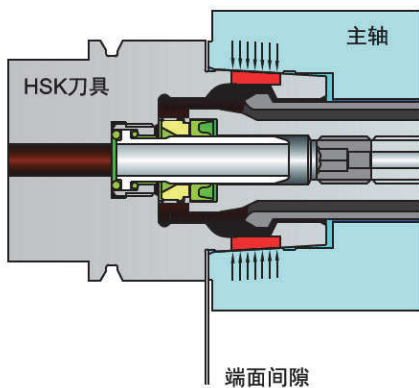

图二 拉杆拉紧后

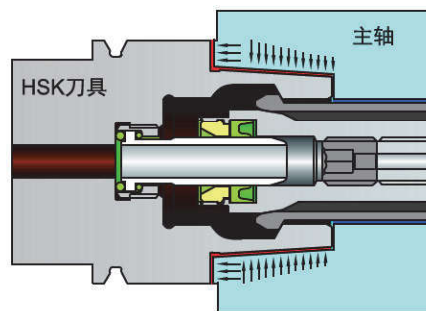

HSK刀柄的空心锥柄与主轴孔完全接触时，HSK刀柄端面与主轴端面有约0.1mm间隙(如图一)。在夹紧机构作用下，拉杆向右移动，夹爪胀开，夹爪外锥面顶在空心锥柄30°锥面上，拉动HSK刀柄向右移动，空心锥柄产生变形。刀柄端面与主轴端面靠紧，实现了刀柄与主轴锥面和端面两面同时定位和夹紧(如上图二)。

D 工具系统 Tool System

HSK短锥型式-A型 HSK-A

对于加工中心的标准设计
带有机手卡槽，适合自动刀具交换
通过冷却润滑管，支持中心冷却润滑供应
锥柄末端有驱动键槽
数据芯片孔 (DIN 69873)为可选配置
包含手动装卸孔，也可以用于C型柄

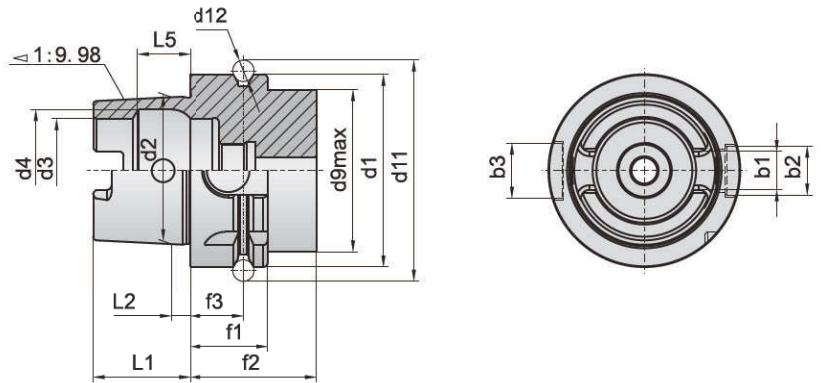

锥柄型式 Taper type	尺寸(mm) Dimension															
	b1	b2	b3	d1	d2	d3	d4	d9	d11	d12	f1	f2	f3	L1	L2	L5
HSK-25A	6.05	6	7	25	19.006	14	15	20	28.5	3	10	20	4.5	13	2.5	7.21
HSK-32A	7.05	7	9	32	24.007	17	19	26	37	4	20	35	16	16	3.2	8.92
HSK-40A	8.05	9	11	40	30.007	21	23	34	45	4	20	35	16	20	4	11.42
HSK-50A	10.54	12	14	50	38.009	26	29	42	59.3	7	26	42	18	25	5	14.13
HSK-63A	12.54	16	18	63	48.010	34	37	53	72.3	7	26	42	18	32	6.3	18.13
HSK-80A	16.04	18	20	80	60.012	42	50	68	88.8	7	26	42	18	40	8	22.85
HSK-100A	20.02	20	22	100	75.013	53	58	88	109.75	7	29	45	20	50	10	28.56

HSK短锥型式-B型 HSK-B

适合加工中心
通过加大法兰接触面可增大径向压力
带有机手卡槽，适合自动刀具交换
通过法兰端面提供冷却润滑供应
锥柄末端有驱动键槽
具有数据芯片孔 (DIN 69873)

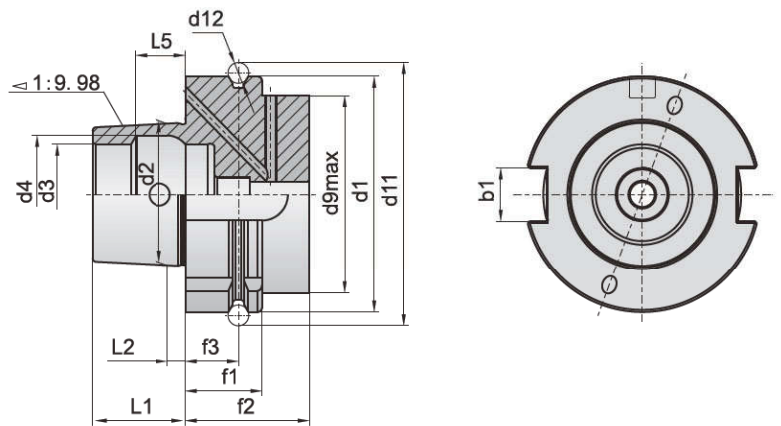

锥柄型式 Taper type	尺寸(mm) Dimension													
	b1	d1	d2	d3	d4	d9	d11	d12	f1	f2	f3	L1	L2	L5
HSK-40B	9	40	24.007	17	19	34	45	4	20	35	16	16	3.2	8.92
HSK-50B	12	50	30.007	21	23	42	59.3	7	26	42	18	20	4	11.42
HSK-63B	16	63	38.009	26	29	53	72.3	7	26	42	18	25	5	14.13
HSK-80B	18	80	48.010	34	37	68	88.8	7	26	42	18	32	6.3	18.13
HSK-100B	20	100	60.012	42	46	88	109.25	7	29	45	20	40	8	22.85
HSK-125B	25	125	75.013	53	58	111	134.75	7	29	45	20	50	10	28.56

D 工具系统 Tool System

HSK短锥型式-C型 HSK-C

适合专机和模块化刀具系统
带有机手卡槽，适合手动换刀
支持中心冷却润滑供应
锥柄末端有驱动键槽

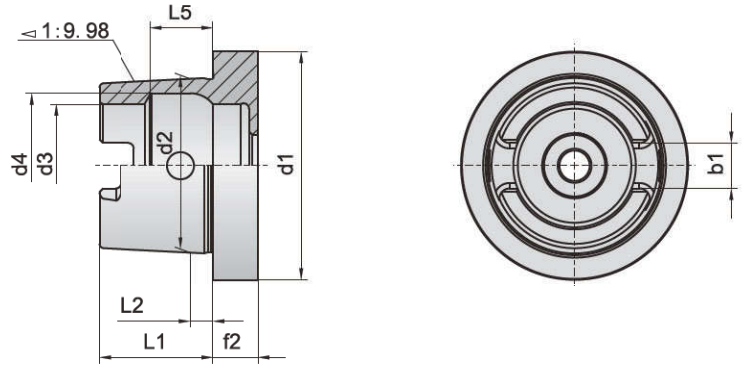

锥柄型式 Taper type	尺寸(mm) Dimension								
	b1	d1	d2	d3	d4	f2	L1	L2	L5
HSK-25C	6.05	25	19.006	14	15	8	13	2.5	7.21
HSK-32C	7.05	32	24.007	17	19	10	16	3.2	8.92
HSK-40C	8.05	40	30.007	21	23	10	20	4	11.42
HSK-50C	10.54	50	38.009	26	29	12.5	25	5	14.13
HSK-63C	12.54	63	48.010	34	37	12.5	32	6.3	18.13
HSK-80C	16.04	80	60.012	42	50	16	40	8	22.85
HSK-100C	20.02	100	75.013	53	58	16	50	10	28.56

HSK短锥型式-D型 HSK-D

适合专机
通过加大法兰接触面可增大径向压力
带有机手卡槽，适合手动刀具交换
通过法兰端面提供冷却润滑供应
锥柄末端有驱动键槽

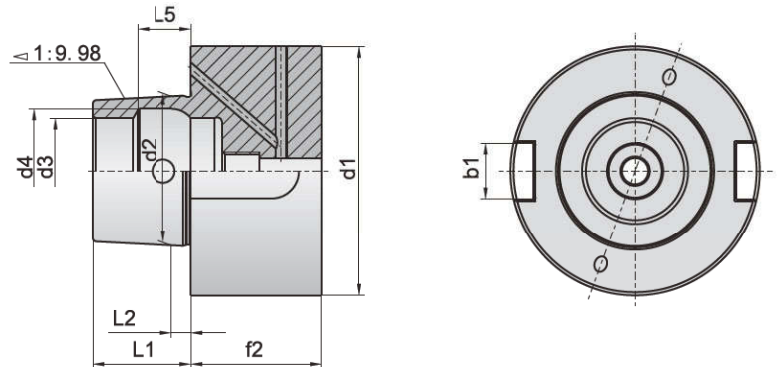

锥柄型式 Taper type	尺寸(mm) Dimension								
	b1	d1	d2	d3	d4	f2	L1	L2	L5
HSK-40D	10	40	24.007	17	19	35	16	3.2	8.92
HSK-50D	12	50	30.007	21	23	35	20	4	11.42
HSK-63D	16	63	38.009	26	29	42	25	5	14.13
HSK-80D	18	80	48.010	34	37	42	32	6.3	18.13
HSK-100D	20	100	60.012	42	50	42	40	8	22.85

工具系统
热胀工具系统
SHRINK FIT HOLDER
HSK工具系统
HSK TOOL SYSTEM
TMG21工具系统
TMG21 TOOL SYSTEM
7:24工具系统
7:24 TOOL SYSTEM
其它工具系统
SPECIAL TOOL SYSTEM
附件
ACCESSORIES

D 工具系统 Tool System

HSK短锥型式-E型 HSK-E

适合高速机床
带有机手卡槽，适合自动刀具交换
通过冷却润滑管，支持中心冷却润滑供应
没有驱动键槽，旋转对称

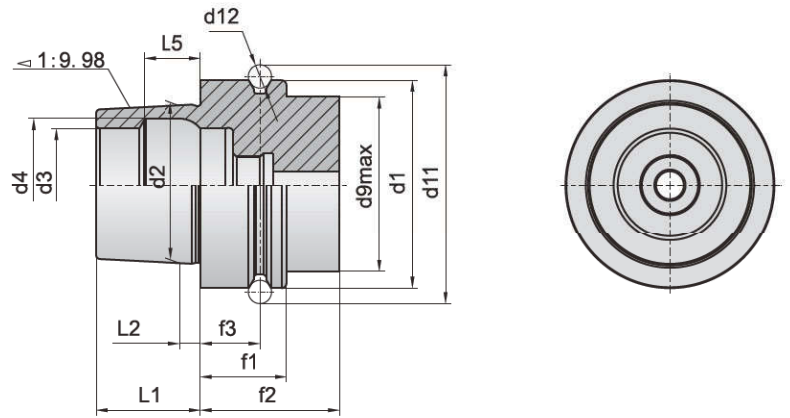

锥柄型式 Taper type	尺寸(mm) Dimension												
	d1	d2	d3	d4	d9	d11	d12	f1	f2	f3	L1	L2	L5
HSK-32E	32	24.007	17	19	26	37	4	20	35	16	16	3.2	8.92
HSK-40E	40	30.007	21	23	34	45	4	20	35	16	20	4	11.42
HSK-50E	50	38.009	26	29	42	59.3	7	26	42	18	25	5	14.13
HSK-63E	63	48.010	34	37	53	72.3	7	26	42	18	32	6.3	18.13
HSK-80E	80	60.012	42	50	68	88.8	7	29	42	18	40	8	22.85

HSK短锥型式-F型 HSK-F

适合高速机床，多用于木工领域
通过加大法兰接触面可增大径向压力
带有机手卡槽，适合自动刀具交换
通过冷却润滑管，支持中心冷却润滑供应
没有驱动键槽，旋转对称

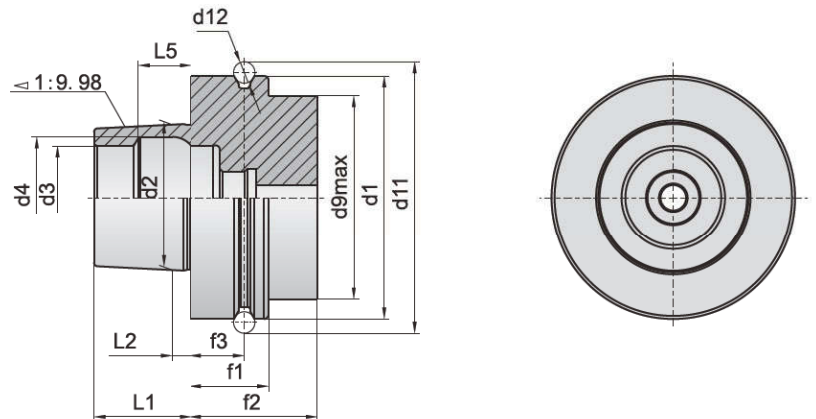

锥柄型式 Taper type	尺寸(mm) Dimension												
	d1	d2	d3	d4	d9	d11	d12	f1	f2	f3	L1	L2	L5
HSK-50F	50	30.007	21	23	42	45	4	20	35	16	20	4	11.42
HSK-63F	63	38.009	26	29	53	59.3	7	26	42	18	25	5	14.13
HSK-80F	80	48.010	34	37	67	72.3	7	26	42	18	32	6.3	18.13

D 工具系统 Tool System

弹簧夹头刀柄-HSK32A/HSK40A/HSK50A
ER Collet Chucks

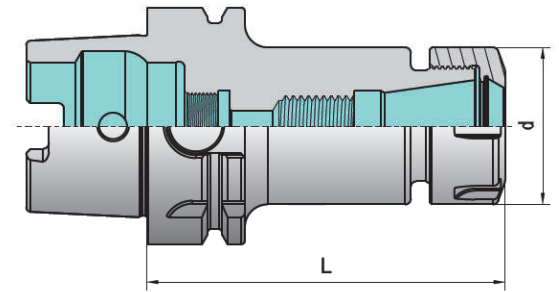

型号 Type	库存 Stock	锥柄型式 Taper type	尺寸(mm) Dimension		螺母 Nut	扳手 Wrench	卡簧 ER collet	螺钉 Screw	重量 (kg)
			d	L					
HSK32A-ER11-80	●	HSK32A	19	80	LN11S	-	ER11	SGC060150	
HSK32A-ER16-80	●	HSK32A	28	80	LN16S	-	ER16	SGC100150	
HSK32A-ER20-80	●	HSK32A	34	80	LN20S	-	ER20	SGC120200	
HSK32A-ER25-80	●	HSK32A	42	80	LN25	WER25	ER25	SGC160200	
HSK40A-ER11-80	●	HSK40A	19	80	LN11S	-	ER11	SGC060150	
HSK40A-ER16-80	●	HSK40A	28	80	LN16S	-	ER16	SGC100150	
HSK40A-ER20-80	●	HSK40A	34	80	LN20S	-	ER20	SGC120200	
HSK40A-ER25-80	●	HSK40A	42	80	LN25	WER25	ER25	SGC160200	
HSK50A-ER16-60	●	HSK50A	28	60	LN16S	-	ER16	SGC100150	
-100	●	HSK50A	28	100	LN16S	-	ER16	SGC100150	
HSK50A-ER20-70	●	HSK50A	34	70	LN20S	-	ER20	SGC120200	
-100	●	HSK50A	34	100	LN20S	-	ER20	SGC120200	
HSK50A-ER25-70	●	HSK50A	42	70	LN25	WER25	ER25	SGC160200	
-100	●	HSK50A	42	100	LN25	WER25	ER25	SGC160200	
HSK50A-ER32-80	●	HSK50A	50	80	LN32	WER32	ER32	SGD220250	
-100	●	HSK50A	50	100	LN32	WER32	ER32	SGD220250	

订货示例: HSK32A-ER11-80 G2.5 25000rpm

● 常备库存 Unallocated stock ● 可备库存 Available stock ○ 订单生产 Order production

工具系统
热胀工具系统 SHRINK FIT HOLDER
HSK工具系统 HSK TOOL SYSTEM
TMG21工具系统 TMG21 TOOL SYSTEM
7:24工具系统 7:24 TOOL SYSTEM
其它工具系统 SPECIAL TOOL SYSTEM
附件 ACCESSORIES

D 工具系统 Tool System

弹簧夹头刀柄-HSK63A ER Collet Chucks

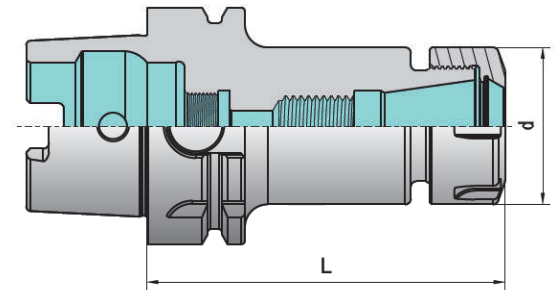
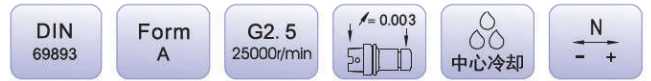

工具系统

SHRINK FIT HOLDER
热胀工具系统

HSK TOOL SYSTEM
HSK工具系统

TMG21 TOOL SYSTEM
TMG21工具系统

7:24 TOOL SYSTEM
7:24工具系统

SPECIAL TOOL SYSTEM
其它工具系统

ACCESSORIES
附件

型号 Type	库存 Stock	锥柄型式 Taper type	尺寸(mm) Dimension		螺母 Nut	扳手 Wrench	卡簧 ER collet	螺钉 Screw	重量 (kg)
			d	L					
HSK63A-ER16-80	●	HSK63A	28	80	LN16S	-	ER16	SGC100150	
-100	●	HSK63A	28	100	LN16S	-	ER16	SGC100150	
-160	●	HSK63A	28	160	LN16S	-	ER16	SGC100150	
HSK63A-ER20-80	●	HSK63A	34	80	LN20S	-	ER20	SGC120200	
-100	●	HSK63A	34	100	LN20S	-	ER20	SGC120200	
-160	●	HSK63A	34	160	LN20S	-	ER20	SGC120200	
HSK63A-ER25-80	●	HSK63A	42	80	LN25	WER25	ER25	SGC160200	
-100	●	HSK63A	42	100	LN25	WER25	ER25	SGC160200	
-160	●	HSK63A	42	160	LN25	WER25	ER25	SGC160200	
HSK63A-ER32-80	●	HSK63A	50	80	LN32	WER32	ER32	SGD220250	
-100	●	HSK63A	50	100	LN32	WER32	ER32	SGD220250	
-160	●	HSK63A	50	160	LN32	WER32	ER32	SGD220250	
HSK63A-ER40-80	●	HSK63A	63	80	LN40	WER40	ER40	SGD280250	
-100	●	HSK63A	63	100	LN40	WER40	ER40	SGD280250	
-160	●	HSK63A	63	160	LN40	WER40	ER40	SGD280250	

订货示例: HSK63A-ER16-80 G2.5 25000rpm

● 常备库存 Unallocated stock ● 可备库存 Available stock ○ 订单生产 Order production

D 工具系统 Tool System

弹簧夹头刀柄-HSK100A
ER Collet Chucks

DIN 69893
Form A
G2.5 15000/min
 ± 0.003
中心冷却
N

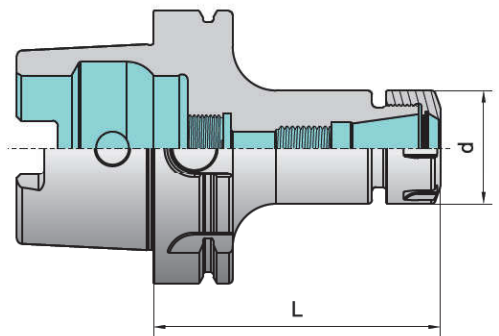

型号 Type	库存 Stock	锥柄型式 Taper type	尺寸(mm) Dimension		螺母 Nut	扳手 Wrench	卡簧 ER collet	螺钉 Screw	重量 (kg)
			d	L					
HSK100A-ER16-100	●	HSK100A	28	100	LN16S	-	ER16	SGC100150	
-160	●	HSK100A	28	160	LN16S	-	ER16	SGC100150	
HSK100A-ER20-100	●	HSK100A	34	100	LN20S	-	ER20	SGC120200	
-160	●	HSK100A	34	160	LN20S	-	ER20	SGC120200	
HSK100A-ER25-100	●	HSK100A	42	100	LN25	WER25	ER25	SGC160200	
-160	●	HSK100A	42	160	LN25	WER25	ER25	SGC160200	
HSK100A-ER32-100	●	HSK100A	50	100	LN32	WER32	ER32	SGD220250	
-160	●	HSK100A	50	160	LN32	WER32	ER32	SGD220250	
HSK100A-ER40-100	●	HSK100A	63	100	LN40	WER40	ER40	SGD280250	
-160	●	HSK100A	63	160	LN40	WER40	ER40	SGD280250	

订货示例: HSK100A-ER16-100 G2.5 15000rpm

● 常备库存 Unallocated stock
● 可备库存 Available stock
○ 订单生产 Order production

工具系统
热胀工具系统 SHRINK FIT HOLDER
HSK工具系统 HSK TOOL SYSTEM
TMG21工具系统 TMG21 TOOL SYSTEM
7:24工具系统 7:24 TOOL SYSTEM
其它工具系统 SPECIAL TOOL SYSTEM
附件 ACCESSORIES

D 工具系统 Tool System

弹簧夹头刀柄-HSK32E/40E/50E
ER Collet Chucks

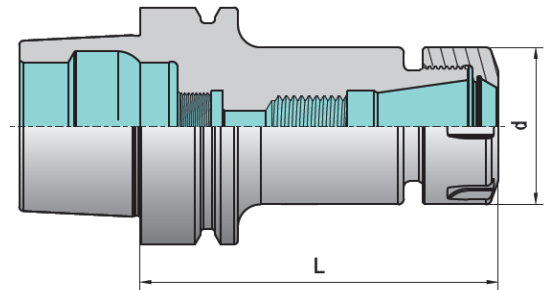
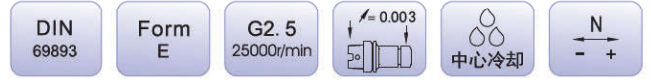

型号 Type	库存 Stock	锥柄型式 Taper type	尺寸(mm) Dimension		螺母 Nut	扳手 Wrench	卡簧 ER collet	螺钉 Screw	重量 (kg)
			d	L					
HSK32E-ER11-80	●	HSK32E	19	80	LN11S	-	ER11	SGC060150	
HSK32E-ER16-80	●	HSK32E	28	80	LN16S	-	ER16	SGC100150	
HSK32E-ER20-80	●	HSK32E	34	80	LN20S	-	ER20	SGC120200	
HSK32E-ER25-80	●	HSK32E	42	80	LN25	WER25	ER25	SGC160200	
HSK40E-ER11-80	●	HSK40E	19	80	LN11S	-	ER11	SGC060150	
HSK40E-ER16-80	●	HSK40E	28	80	LN16S	-	ER16	SGC100150	
HSK40E-ER20-80	●	HSK40E	34	80	LN20S	-	ER20	SGC120200	
HSK40E-ER25-80	●	HSK40E	42	80	LN25	WER25	ER25	SGC160200	
HSK50E-ER16-60	●	HSK50E	28	60	LN16S	-	ER16	SGC100150	
-100	●	HSK50E	28	100	LN16S	-	ER16	SGC100150	
HSK50E-ER20-70	●	HSK50E	34	70	LN20S	-	ER20	SGC120200	
HSK50E-ER25-70	●	HSK50E	42	70	LN25	WER25	ER25	SGC160200	
-100	●	HSK50E	42	100	LN25	WER25	ER25	SGC160200	
HSK50E-ER32-80	●	HSK50E	50	80	LN32	WER32	ER32	SGD220250	
-100	●	HSK50E	50	100	LN32	WER32	ER32	SGD220250	

订货示例: HSK32E-ER11-80 G2.5 25000rpm

● 常备库存 Unallocated stock ● 可备库存 Available stock ○ 订单生产 Order production

D 工具系统 Tool System

弹簧夹头刀柄-HSK63F
ER Collet Chucks

DIN 69893
Form F
G2.5 25000/min
 $\nabla = 0.003$
中心冷却
N

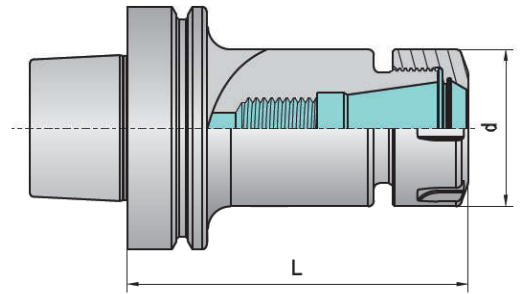

型号 Type	库存 Stock	锥柄型式 Taper type	尺寸(mm) Dimension		螺母 Nut	扳手 Wrench	卡簧 ER collet	螺钉 Screw	重量 (kg)
			d	L					
HSK63F-ER16-75	●	HSK63F	28	75	LN16S	-	ER16	SGC100150	
-100	●	HSK63F	28	100	LN16S	-	ER16	SGC100150	
HSK63F-ER20-75	●	HSK63F	34	75	LN20S	-	ER20	SGC120200	
-100	●	HSK63F	34	100	LN20S	-	ER20	SGC120200	
HSK63F-ER25-75	●	HSK63F	42	75	LN25	WER25	ER25	SGC160200	
-100	●	HSK63F	42	100	LN25	WER25	ER25	SGC160200	
HSK63F-ER32-75	●	HSK63F	50	80	LN32	WER32	ER32	SGD220250	
-100	●	HSK63F	50	100	LN32	WER32	ER32	SGD220250	
HSK63F-ER40-75	●	HSK63F	63	80	LN40	WER40	ER40	SGD280250	
-100	●	HSK63F	63	100	LN40	WER40	ER40	SGD280250	

订货示例: HSK63F-ER16-75 G2.5 25000rpm

● 常备库存 Unallocated stock
● 可备库存 Available stock
○ 订单生产 Order production

工具系统
 热胀工具系统 SHRINK FIT HOLDER
 HSK工具系统 HSK TOOL SYSTEM
 TMG21工具系统 TMG21 TOOL SYSTEM
 7:24工具系统 7:24 TOOL SYSTEM
 其它工具系统 SPECIAL TOOL SYSTEM
 附件 ACCESSORIES

D 工具系统 Tool System

液压刀柄-HSK63A
Hydraulic Chucks

DIN 69893
Form A
 $\sqrt{r=0.003}$
中心冷却
N

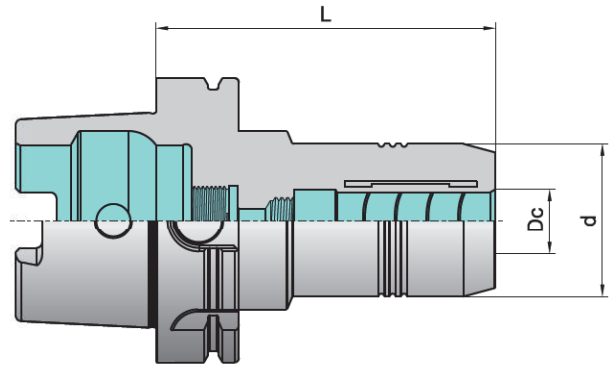

型号 Type	库存 Stock	锥柄型式 Taper type	尺寸(mm) Dimension			卡簧 HC collet	扳手 Wrench	重量 (kg)
			Dc	d	L			
HSK63A-KHC12-85	●	HSK63A	12	34	85	HC12	TS4	
HSK63A-KHC20-90	●	HSK63A	20	43	90	HC20	TS4	
HSK63A-KHC25-120	●	HSK63A	25	57	120	-	TS5	
HSK63A-KHC32-125	●	HSK63A	32	64	125	HC32	TS5	

订货示例: HSK63A-KHC12-85

● 常备库存 Unallocated stock
● 可备库存 Available stock
○ 订单生产 Order production

工具系统
 SHRINK FIT HOLDER 热胀工具系统
 HSK TOOL SYSTEM HSK工具系统
 TMG21 TOOL SYSTEM TMG21工具系统
 7:24 TOOL SYSTEM 7:24工具系统
 SPECIAL TOOL SYSTEM 其它工具系统
 ACCESSORIES 附件

D 工具系统 Tool System

液压刀柄-HSK100A
Hydraulic Chucks

DIN 69893
Form A
 $\lambda = 0.003$
中心冷却
N

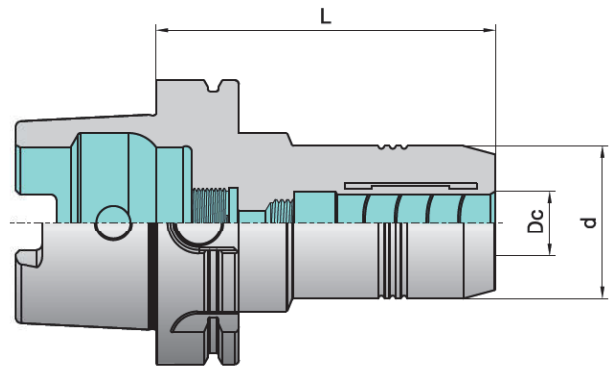

型号 Type	库存 Stock	锥柄型式 Taper type	尺寸(mm) Dimension			卡簧 HC collet	扳手 Wrench	重量 (kg)
			Dc	d	L			
HSK100A-KHC12-95	●	HSK100A	12	34	95	HC12	TS4	
HSK100A-KHC20-105	●	HSK100A	20	43	105	HC20	TS4	
HSK100A-KHC25-110	●	HSK100A	25	57	110	-	TS5	
HSK100A-KHC32-110	●	HSK100A	32	63	110	HC32	TS5	

订货示例: HSK63A-KHC12-85

- 常备库存 Unallocated stock
- 可备库存 Available stock
- 订单生产 Order production

工具系统
热胀工具系统 SHRINK FIT HOLDER
HSK工具系统 HSK TOOL SYSTEM
TMG21工具系统 TMG21 TOOL SYSTEM
7:24工具系统 7:24 TOOL SYSTEM
其它工具系统 SPECIAL TOOL SYSTEM
附件 ACCESSORIES

D 工具系统 Tool System

强力夹头刀柄-HSK63A
Power Chucks

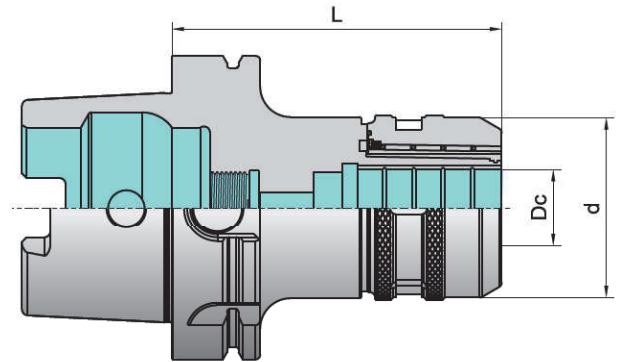
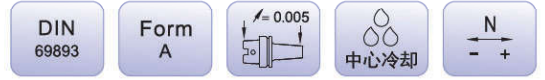

工具系统

SHRINK FIT HOLDER
热胀工具系统

HSK TOOL SYSTEM
HSK工具系统

TMG21 TOOL SYSTEM
TMG21工具系统

7:24 TOOL SYSTEM
7:24工具系统

SPECIAL TOOL SYSTEM
其它工具系统

ACCESSORIES
附件

型号 Type	库存 Stock	锥柄型式 Taper type	尺寸(mm) Dimension			卡簧 C collet	扳手 Wrench	重量 (kg)
			Dc	d	L			
HSK63A-KMC20-100	●	HSK63A	20	53	100	C20	WKMC20	
HSK63A-KMC25-110	●	HSK63A	25	62	110	C25	WKMC25	
HSK63A-KMC32-105	●	HSK63A	32	70	105	C32	WKMC32	

订货示例: HSK63A-KMC20-100

● 常备库存 Unallocated stock ● 可备库存 Available stock ○ 订单生产 Order production

D 工具系统 Tool System

强力夹头刀柄-HSK100A
Power Chucks

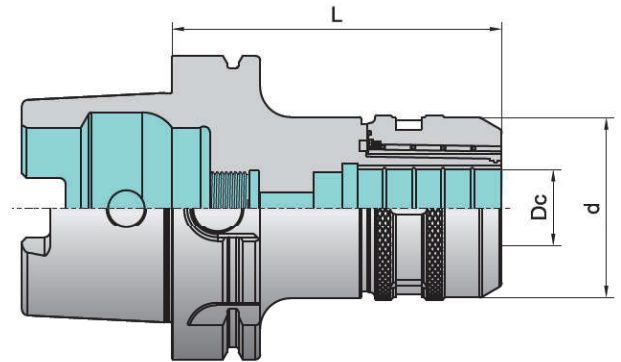
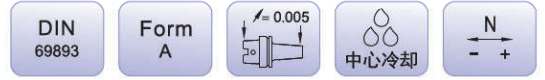

型号 Type	库存 Stock	锥柄型式 Taper type	尺寸(mm) Dimension			卡簧 C collet	扳手 Wrench	重量 (kg)
			Dc	d	L			
HSK100A-KMC25-110	●	HSK100A	25	62	110	C25	WKMC25	
HSK100A-KMC32-135	●	HSK100A	32	70	135	C32	WKMC32	
HSK100A-KMC42-140	●	HSK100A	42	92	140	C42	WKMC42	

订货示例: HSK100A-KMC25-110

● 常备库存 Unallocated stock ● 可备库存 Available stock ○ 订单生产 Order production

工具系统
热胀工具系统 SHRINK FIT HOLDER
HSK工具系统 HSK TOOL SYSTEM
TMG21工具系统 TMG21 TOOL SYSTEM
7:24工具系统 7:24 TOOL SYSTEM
其它工具系统 SPECIAL TOOL SYSTEM
附件 ACCESSORIES

D 工具系统 Tool System

侧固式刀柄-HSK63A Side-Locked Holders

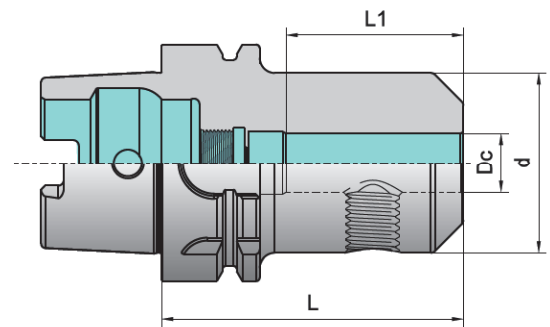
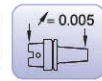

型号 Type	库存 Stock	锥柄型式 Taper type	尺寸(mm) Dimension				螺钉 Screw	扳手 Wrench	重量 (kg)
			Dc	d	L1	L			
HSK63A-XP12-80	●	HSK63A	12	42	44	80	SXP12	S6	
-160	●	HSK63A	12	42	44	160	SXP12	S6	
HSK63A-XP16-80	●	HSK63A	16	48	47	80	SXP16	S6	
-160	●	HSK63A	16	48	47	160	SXP16	S6	
HSK63A-XP20-80	●	HSK63A	20	52	49	80	SXP20	S8	
-160	●	HSK63A	20	52	49	160	SXP20	S8	
HSK63A-XP25-110	●	HSK63A	25	65	54	110	SXP25	S8	
-160	●	HSK63A	25	65	54	160	SXP25	S8	
HSK63A-XP32-110	●	HSK63A	32	72	58	110	SXP32	S10	
-160	●	HSK63A	32	72	58	160	SXP32	S10	

订货示例: HSK63A-XP12-80

● 常备库存
Unallocated stock

● 可备库存
Available stock

○ 订单生产
Order production

D 工具系统 Tool System

侧固式刀柄-HSK100A
Side-Locked Holders

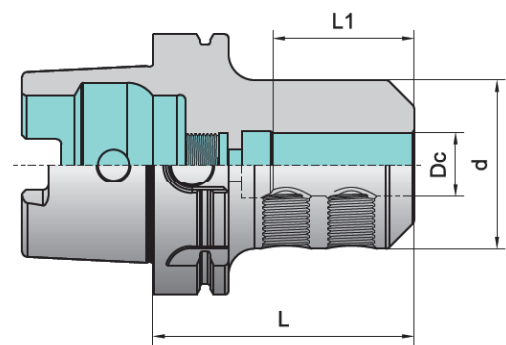
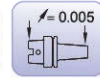

型号 Type	库存 Stock	锥柄型式 Taper type	尺寸(mm) Dimension				螺钉 Screw	扳手 Wrench	重量 (kg)
			Dc	d	L1	L			
HSK100A-XP16-100	●	HSK100A	16	48	47	100	SXP16	S6	
-160	●	HSK100A	16	48	47	160	SXP16	S6	
HSK100A-XP20-100	●	HSK100A	20	52	49	100	SXP20	S8	
-160	●	HSK100A	20	52	49	160	SXP20	S8	
HSK100A-XP25-100	●	HSK100A	25	65	54	100	SXP25	S8	
-160	●	HSK100A	25	65	54	160	SXP25	S8	
HSK100A-XP32-100	●	HSK100A	32	72	58	100	SXP32	S10	
-160	●	HSK100A	32	72	58	160	SXP32	S10	
HSK100A-XP40-120	●	HSK100A	40	80	68	120	SXP40	S10	
-160	●	HSK100A	40	80	68	160	SXP40	S10	

订货示例: HSK100A-XP16-100

● 常备库存
Unallocated stock

● 可备库存
Available stock

○ 订单生产
Order production

工具系统
HSK工具系统
HSK TOOL SYSTEM
HSK TOOL SYSTEM
HSK TOOL SYSTEM
7:24工具系统
7/24 TOOL SYSTEM
其它工具系统
SPECIAL TOOL SYSTEM
附件
ACCESSORIES

D 工具系统 Tool System

面铣刀刀柄-HSK40A
Shell Mill Holder

DIN 69893
Form A
G2.5 25000r/min
 $\sqrt{R=0.01}$



型式 I

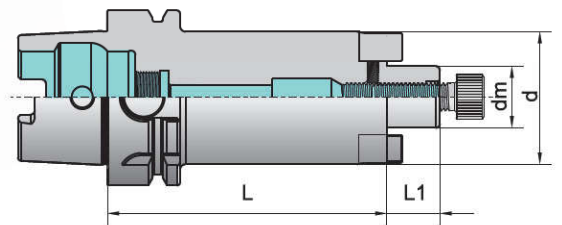
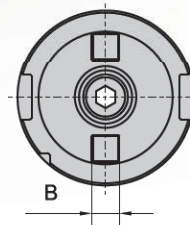

型号 Type	库存 Stock	锥柄型式 Taper type	尺寸(mm) Dimension						螺钉 Screw	扳手 Wrench	键 Key	型式 Model	重量 (kg)
			dm	d	d1	B	L1	L					
HSK40A-XMA16-50	●	HSK40A	16	38	-	8	17	50	SCC080300	S6	KXMA16	I	
HSK40A-XMA22-50	●	HSK40A	22	48	-	10	19	50	SCC100300	S8	KXMA22	I	
HSK40A-XMA27-60	●	HSK40A	27	60	-	12	21	60	SCC120350	S10	KXMA27	I	

订货示例: HSK40A-XMA16-50 G2.5 25000rpm

- 常备库存 Unallocated stock
- 可备库存 Available stock
- 订单生产 Order production

D 工具系统 Tool System

面铣刀刀柄-HSK63A Shell Mill Holder

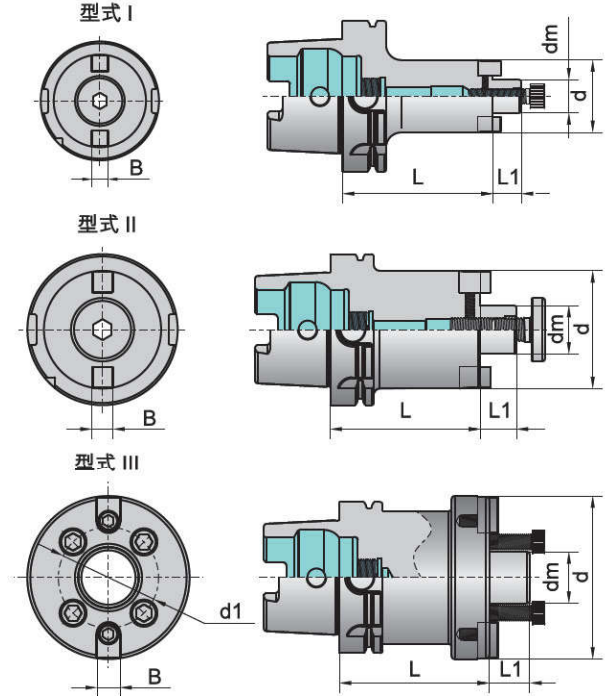

型号 Type	库存 Stock	锥柄型式 Taper type	尺寸(mm) Dimension						螺钉 Screw	扳手 Wrench	键 Key	型式 Model	重量 (kg)
			dm	d	d1	B	L1	L					
HSK63A-XMA22-50	●	HSK63A	22	48	—	10	19	50	SCC100300	S8	KXMA22	I	
-100	●	HSK63A	22	48	—	10	19	100	SCC100300	S8	KXMA22	I	
-160	●	HSK63A	22	48	—	10	19	160	SCC100300	S8	KXMA22	I	
HSK63A-XMA27-60	●	HSK63A	27	60	—	12	21	60	SCC120350	S10	KXMA27	I	
-100	●	HSK63A	27	60	—	12	21	100	SCC120350	S10	KXMA27	I	
-160	●	HSK63A	27	60	—	12	21	160	SCC120350	S10	KXMA27	I	
HSK63A-XMB32-60	●	HSK63A	32	78	—	14	24	60	SXMB32	S12	KXMB32	II	
-100	●	HSK63A	32	78	—	14	24	100	SXMB32	S12	KXMB32	II	
-160	●	HSK63A	32	78	—	14	24	160	SXMB32	S12	KXMB32	II	
HSK63A-XMB40-60	●	HSK63A	40	89	—	16	27	60	SXMB40	S14	KXMB40	II	
-100	●	HSK63A	40	89	—	16	27	100	SXMB40	S14	KXMB40	II	
-160	●	HSK63A	40	89	—	16	27	160	SXMB40	S14	KXMB40	II	
HSK63A-XMC40-60	●	HSK63A	40	108	66.7	16	27	60	SCC120350	S10	KXMC40	III	

订货示例: HSK63A-XMA22-50 G2.5 25000rpm

● 常备库存 Unallocated stock ● 可备库存 Available stock ○ 订单生产 Order production

D 工具系统 Tool System

面铣刀刀柄-HSK100A
Shell Mill Holder

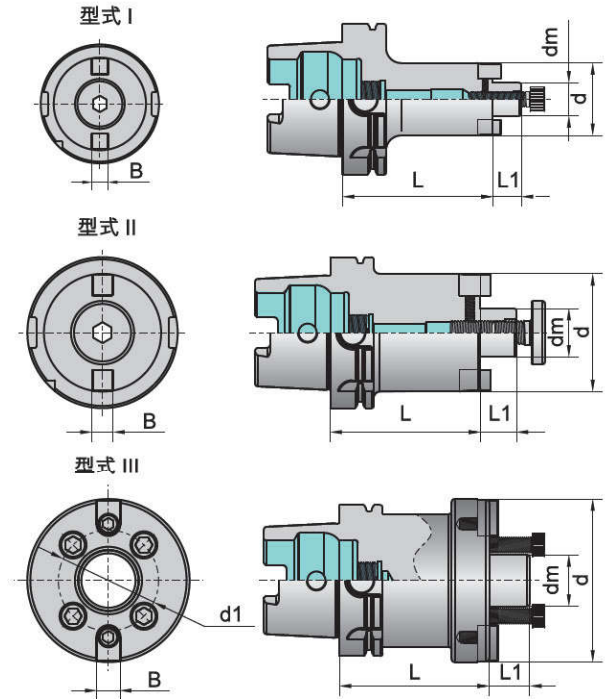

型号 Type	库存 Stock	锥柄型式 Taper type	尺寸(mm) Dimension						螺钉 Screw	扳手 Wrench	键 Key	型式 Model	重量 (kg)
			dm	d	d1	B	L1	L					
HSK100A-XMA22-50	●	HSK100A	22	48	—	10	19	50	SCC100300	S8	KXMA22	I	
-100	●	HSK100A	22	48	—	10	19	100	SCC100300	S8	KXMA22	I	
-160	●	HSK100A	22	48	—	10	19	160	SCC100300	S8	KXMA22	I	
HSK100A-XMA27-50	●	HSK100A	27	60	—	12	21	50	SCC120350	S10	KXMA27	I	
-100	●	HSK100A	27	60	—	12	21	100	SCC120350	S10	KXMA27	I	
-160	●	HSK100A	27	60	—	12	21	160	SCC120350	S10	KXMA27	I	
HSK100A-XMB32-50	●	HSK100A	32	78	—	14	24	50	SXMB32	S12	KXMB32	II	
-100	●	HSK100A	32	78	—	14	24	100	SXMB32	S12	KXMB32	II	
-160	●	HSK100A	32	78	—	14	24	160	SXMB32	S12	KXMB32	II	
HSK100A-XMB40-60	●	HSK100A	40	89	—	16	27	60	SXMB40	S14	KXMB40	II	
-100	●	HSK100A	40	89	—	16	27	100	SXMB40	S14	KXMB40	II	
-160	●	HSK100A	40	89	—	16	27	160	SXMB40	S14	KXMB40	II	
HSK100A-XMC40-60	●	HSK100A	40	108	66.7	16	27	60	SCC120350	S10	KXMC40	III	
HSK100A-XMC60-70	●	HSK100A	40	129	101.6	25.4	38	70	SCC160450	S14	KXMC60	III	

订货示例: HSK100A-XMA22-50 G2.5 15000rpm

● 常备库存 Unallocated stock ● 可备库存 Available stock ○ 订单生产 Order production

D 工具系统 Tool System

面铣刀刀柄-HSK63F
Shell Mill Holder

DIN 69893
Form F
G2.5 25000r/min
 $\sqrt{0.01}$



型式 I

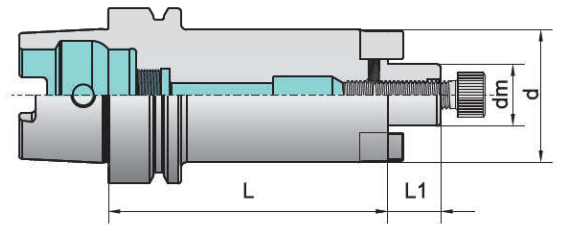
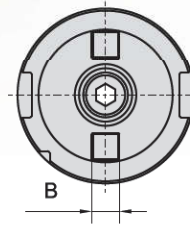

型号 Type	库存 Stock	锥柄型式 Taper type	尺寸(mm) Dimension						螺钉 Screw	扳手 Wrench	键 Key	型式 Model	重量 (kg)
			dm	d	d1	B	L1	L					
HSK63F-XMA22-50	●	HSK63F	22	48	—	10	19	50	SCC100300	S8	KXMA22	I	
HSK63F-XMA27-60	●	HSK63F	27	60	—	12	21	60	SCC120350	S10	KXMA27	I	

订货示例: HSK63F-XMA22-50 G2.5 25000rpm

- 常备库存 Unallocated stock
- 可备库存 Available stock
- 订单生产 Order production

工具系统
 热胀工具系统 SHRINK FIT HOLDER
 HSK工具系统 HSK TOOL SYSTEM
 TMG21工具系统 TMG21 TOOL SYSTEM
 7:24工具系统 7:24 TOOL SYSTEM
 其它工具系统 SPECIAL TOOL SYSTEM
 附件 ACCESSORIES

D 工具系统 Tool System

套式立铣刀及三面刃铣刀刀柄-HSK63A
Shell Mill&Disc Mill Holder

DIN
69893

Form
A

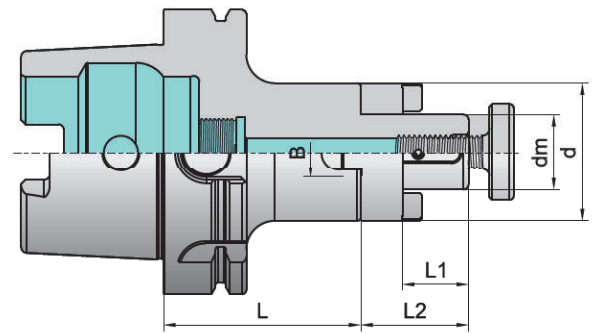
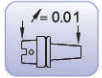

工具系统

SHRINK FIT HOLDER
热胀工具系统

HSK TOOL SYSTEM
HSK工具系统

TMG21 TOOL SYSTEM
TMG21工具系统

7:24 TOOL SYSTEM
7:24工具系统

SPECIAL TOOL SYSTEM
其它工具系统

ACCESSORIES
附件

型号 Type	库存 Stock	锥柄型式 Taper type	尺寸(mm) Dimension						驱动环 Driven ring	键 Key	螺钉 Screw	扳手 Wrench	重量 (kg)
			dm	d	B	L1	L2	L					
HSK63A-XSL16-60	●	HSK63A	16	32	8	17	27	60	DXSL16	KXSL16	SXSL16	S6	
-100	●	HSK63A	16	32	8	17	27	100	DXSL16	KXSL16	SXSL16	S6	
HSK63A-XSL22-60	●	HSK63A	22	40	10	19	31	60	DXSL22	KXSL22	SXSL22	S8	
-100	●	HSK63A	22	40	10	19	31	100	DXSL22	KXSL22	SXSL22	S8	
HSK63A-XSL27-60	●	HSK63A	27	48	12	21	33	60	DXSL27	KXSL27	SXSL27	S10	
-100	●	HSK63A	27	48	12	21	33	100	DXSL27	KXSL27	SXSL27	S10	
HSK63A-XSL32-60	●	HSK63A	32	58	14	24	38	60	DXSL32	KXSL32	SXSL32	S12	
-100	●	HSK63A	32	58	14	24	38	100	DXSL32	KXSL32	SXSL32	S12	
HSK63A-XSL40-70	●	HSK63A	40	70	16	27	41	70	DXSL40	KXSL40	SXSL40	S14	
-100	●	HSK63A	40	70	16	27	41	100	DXSL40	KXSL40	SXSL40	S14	

订货示例: HSK63A-XSL16-60

● 常备库存
Unallocated stock

● 可备库存
Available stock

○ 订单生产
Order production

D 工具系统 Tool System

套式立铣刀及三面刃铣刀刀柄-HSK100A
Shell Mill&Disc Mill Holder

DIN
69893

Form
A

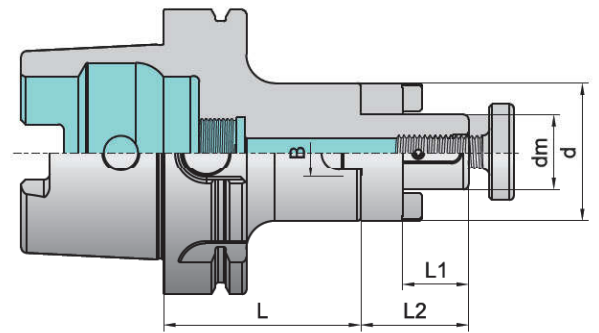
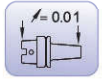

型号 Type	库存 Stock	锥柄型式 Taper type	尺寸(mm) Dimension						驱动环 Driven ring	键 Key	螺钉 Screw	扳手 Wrench	重量 (kg)
			dm	d	B	L1	L2	L					
HSK100A-XSL16-60	●	HSK100A	16	32	8	17	27	60	DXSL16	KXSL16	SXSL16	S6	
-100	●	HSK100A	16	32	8	17	27	100	DXSL16	KXSL16	SXSL16	S6	
HSK100A-XSL22-60	●	HSK100A	22	40	10	19	31	60	DXSL22	KXSL22	SXSL22	S8	
-100	●	HSK100A	22	40	10	19	31	100	DXSL22	KXSL22	SXSL22	S8	
HSK100A-XSL27-60	●	HSK100A	27	48	12	21	33	60	DXSL27	KXSL27	SXSL27	S10	
-100	●	HSK100A	27	48	12	21	33	100	DXSL27	KXSL27	SXSL27	S10	
HSK100A-XSL32-60	●	HSK100A	32	58	14	24	38	60	DXSL32	KXSL32	SXSL32	S12	
-100	●	HSK100A	32	58	14	24	38	100	DXSL32	KXSL32	SXSL32	S12	
HSK100A-XSL40-70	●	HSK100A	40	70	16	27	41	70	DXSL40	KXSL40	SXSL40	S14	
-100	●	HSK100A	40	70	16	27	41	100	DXSL40	KXSL40	SXSL40	S15	

订货示例: HSK100A-XSL16-60

● 常备库存
Unallocated stock

● 可备库存
Available stock

○ 订单生产
Order production

工具系统
热胀工具系统
SHRINK FIT HOLDER
HSK工具系统
HSK TOOL SYSTEM
TMG21工具系统
TMG21 TOOL SYSTEM
7:24工具系统
7:24 TOOL SYSTEM
其它工具系统
SPECIAL TOOL SYSTEM
附件
ACCESSORIES

D 工具系统 Tool System

三面刃铣刀刀柄-HSK63A Disc Cutter Holders

DIN
69893

Form
A

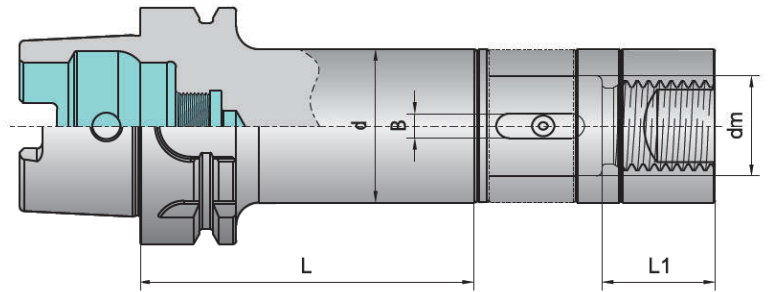
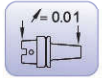

型号 Type	库存 Stock	锥柄型式 Taper type	尺寸(mm) Dimension					三面刃铣刀直径 Slotting cutter dia.	锯片铣刀直径 Disc dia.	键 Key	垫圈(成组) Shim set	螺母 Nut	重量 (kg)
			dm	d	B	L1	L						
HSK63A-XS13-75	●	HSK63A	13	20	—	15	75	—	50	—	GXS13	NXS13	
HSK63A-XS16-90	●	HSK63A	16	27	4	20	90	50	63	KXS16	GXS16	NXS16	
-120	●	HSK63A	16	27	4	20	120	50	63	KXS16	GXS16	NXS16	
HSK63A-XS22-90	●	HSK63A	22	34	6	25	90	63	80、100、125	KXS22	GXS22	NXS22	
-135	●	HSK63A	22	34	6	25	135	63	80、100、125	KXS22	GXS22	NXS22	
HSK63A-XS27-90	●	HSK63A	27	41	7	30	90	80	100、125	KXS27	GXS27	NXS27	
-135	●	HSK63A	27	41	7	30	135	80	100、125	KXS27	GXS27	NXS27	
HSK63A-XS32-90	●	HSK63A	32	47	8	35	90	100、125	160、200、250	KXS32	GXS32	NXS32	
-135	●	HSK63A	32	47	8	35	135	100、125	160、200、250	KXS32	GXS32	NXS32	

订货示例: HSK63A-XS13-75

● 常备库存
Unallocated stock

● 可备库存
Available stock

○ 订单生产
Order production

D 工具系统 Tool System

三面刃铣刀刀柄-HSK100A
Disc Cutter Holders

DIN
69893

Form
A

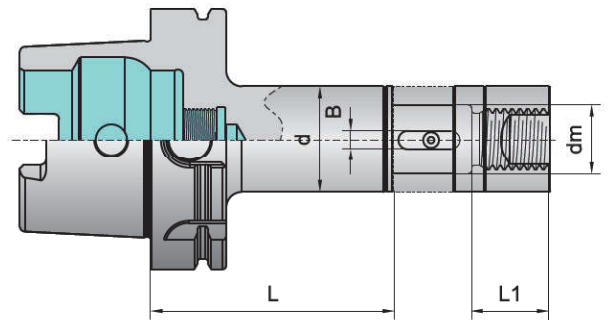
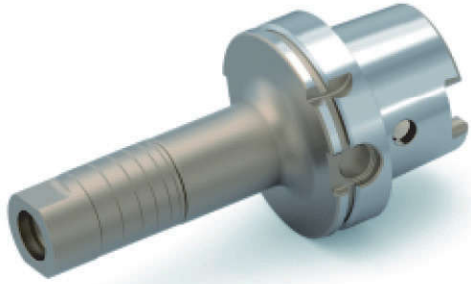
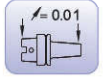

型号 Type	库存 Stock	锥柄型式 Taper type	尺寸(mm) Dimension					三面刃铣刀直径 Slotting cutter dia.	锯片铣刀直径 Disc dia.	键 Key	垫圈(成组) Shim set	螺母 Nut	重量 (kg)
			dm	d	B	L1	L						
HSK100A-XS13-75	●	HSK100A	13	20	—	15	75	—	50	—	GXS13	NXS13	
HSK100A-XS16-90	●	HSK100A	16	27	4	20	90	50	63	KXS16	GXS16	NXS16	
-120	●	HSK100A	16	27	4	20	120	50	63	KXS16	GXS16	NXS16	
HSK100A-XS22-90	●	HSK100A	22	34	6	25	90	63	80、100、125	KXS22	GXS22	NXS22	
-135	●	HSK100A	22	34	6	25	135	63	80、100、125	KXS22	GXS22	NXS22	
HSK100A-XS27-90	●	HSK100A	27	41	7	30	90	80	100、125	KXS27	GXS27	NXS27	
-135	●	HSK100A	27	41	7	30	135	80	100、125	KXS27	GXS27	NXS27	
HSK100A-XS32-90	●	HSK100A	32	47	8	35	90	100、125	160、200、250	KXS32	GXS32	NXS32	
-135	●	HSK100A	32	47	8	35	135	100、125	160、200、250	KXS32	GXS32	NXS32	
HSK100A-XS40-90	●	HSK100A	40	55	10	40	90	160、200	315	KXS40	GXS40	NXS40	
-135	●	HSK100A	40	55	10	40	135	160、200	315	KXS40	GXS40	NXS40	

订货示例: HSK100A-XS13-75

● 常备库存
Unallocated stock

● 可备库存
Available stock

○ 订单生产
Order production

D 工具系统 Tool System

有扁尾莫氏圆锥孔刀柄-HSK63A
Morse Taper Shank with Tang

DIN
69893

Form
A

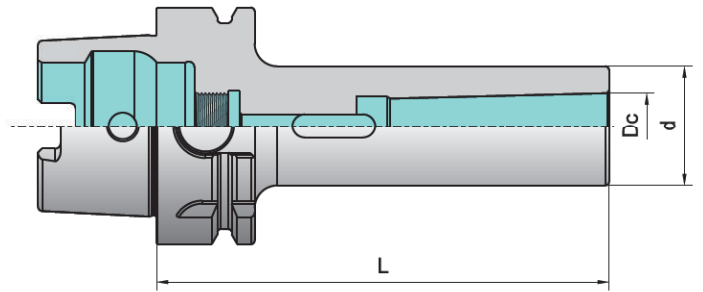
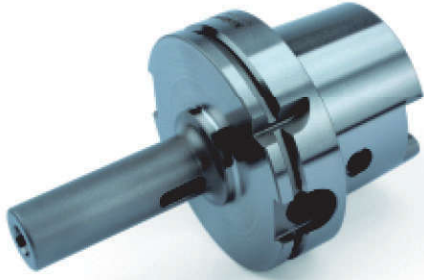
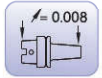

型号 Type	库存 Stock	锥柄型式 Taper type	莫氏锥度 Morse taper	尺寸(mm) Dimension			安装钻头直径 Drill bit dia.	重量 (kg)
				Dc	d	L		
HSK63A-M1-100	●	HSK63A	MT1	12.065	25	100	3~14	
HSK63A-M2-120	●	HSK63A	MT2	17.78	32	120	14.25~23	
HSK63A-M3-140	●	HSK63A	MT3	23.825	40	140	23.25~31.75	
HSK63A-M4-160	●	HSK63A	MT4	31.267	50	160	32~50.5	

订货示例: HSK63A-M1-100

- 常备库存 Unallocated stock
- 可备库存 Available stock
- 订单生产 Order production

工具系统
 SHRINK FIT HOLDER 热胀工具系统
 HSK TOOL SYSTEM HSK工具系统
 TMG21 TOOL SYSTEM TMG21工具系统
 7:24 TOOL SYSTEM 7:24工具系统
 SPECIAL TOOL SYSTEM 其它工具系统
 ACCESSORIES 附件

D 工具系统 Tool System

有扁尾莫氏圆锥孔刀柄-HSK100A
Morse Taper Shank with Tang

DIN
69893

Form
A

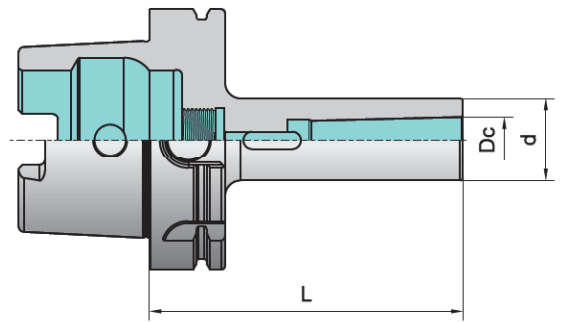
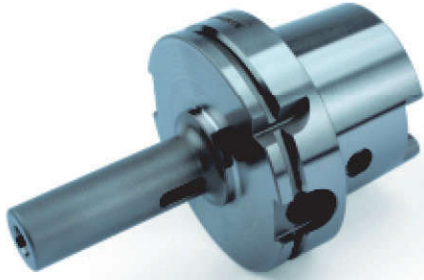
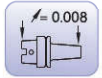

型号 Type	库存 Stock	锥柄型式 Taper type	莫氏锥度 Morse taper	尺寸(mm) Dimension			安装钻头直径 Drill bit dia.	重量 (kg)
				Dc	d	L		
HSK100A-M1-110	●	HSK100A	MT1	12.065	25	110	3~14	
HSK100A-M2-120	●	HSK100A	MT2	17.78	32	120	14.25~23	
HSK100A-M3-150	●	HSK100A	MT3	23.825	40	150	23.25~31.75	
HSK100A-M4-170	●	HSK100A	MT4	31.267	50	170	32~50.5	
HSK100A-M5-200	●	HSK100A	MT5	44.399	70	200	51~76	

订货示例: HSK100A-M1-110

● 常备库存
Unallocated stock

● 可备库存
Available stock

○ 订单生产
Order production

D 工具系统 Tool System

无扁尾莫氏圆锥孔刀柄-HSK63A
Morse Taper Shank without Tang

DIN
69893

Form
A

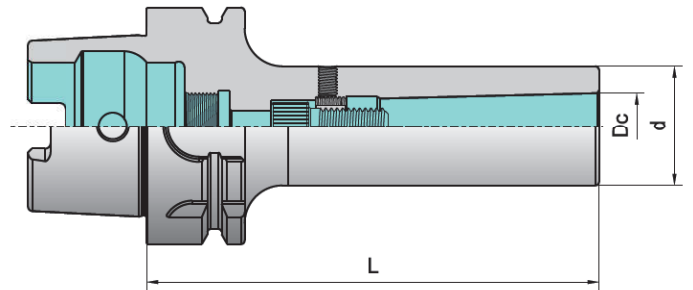
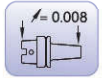

型号 Type	库存 Stock	锥柄型式 Taper type	莫氏锥度 Morse taper	尺寸(mm) Dimension			螺钉 Screw	扳手 Wrench	安装钻头直径 Drill bit dia.	重量 (kg)
				Dc	d	L				
HSK63A-MW1-100	●	HSK63A	MT1	12.065	25	100	SCC060250	S5	3~14	
HSK63A-MW2-120	●	HSK63A	MT2	17.78	32	120	SCC100300A	S8	14.25~23	
HSK63A-MW3-140	●	HSK63A	MT3	23.825	40	140	SCC120350A	S10	23.25~31.75	
HSK63A-MW4-160	●	HSK63A	MT4	31.267	50	160	SCC160400B	S12	32~50.5	

订货示例: HSK63A-MW1-100

● 常备库存 Unallocated stock ● 可备库存 Available stock ○ 订单生产 Order production

D 工具系统 Tool System

无扁尾莫氏圆锥孔刀柄-HSK100A
Morse Taper Shank without Tang

DIN
69893

Form
A

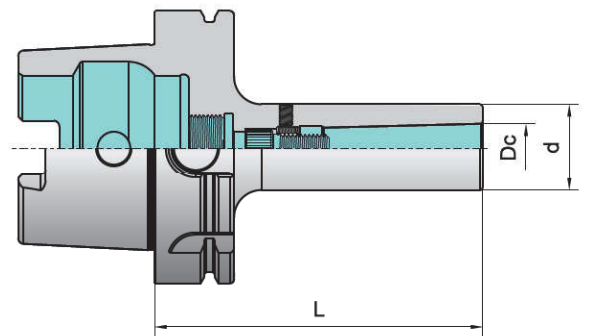
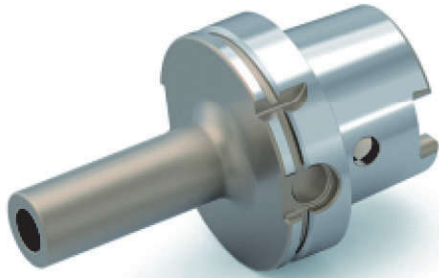
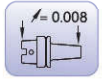

型号 Type	库存 Stock	锥柄型式 Taper type	莫氏锥度 Morse taper	尺寸(mm) Dimension			螺钉 Screw	扳手 Wrench	安装钻头直径 Drill bit dia.	重量 (kg)
				Dc	d	L				
HSK100A-MW2-120	●	HSK100A	MT2	17.78	32	120	SCC100300	S8	14.25~23	
HSK100A-MW3-150	●	HSK100A	MT3	23.825	40	150	SCC120350	S10	23.25~31.75	
HSK100A-MW4-170	●	HSK100A	MT4	31.267	50	170	SCC160400A	S14	32~50.5	

订货示例: HSK100A-MW2-120

● 常备库存 Unallocated stock ● 可备库存 Available stock ○ 订单生产 Order production

工具系统
热胀工具系统 SHRINK FIT HOLDER
HSK工具系统 HSK TOOL SYSTEM
TMG21工具系统 TMG21 TOOL SYSTEM
7:24工具系统 7:24 TOOL SYSTEM
其它工具系统 SPECIAL TOOL SYSTEM
附件 ACCESSORIES

D 工具系统 Tool System

整体式钻夹头刀柄-HSK63A
Integral Drill Chucks

DIN
69893

Form
A

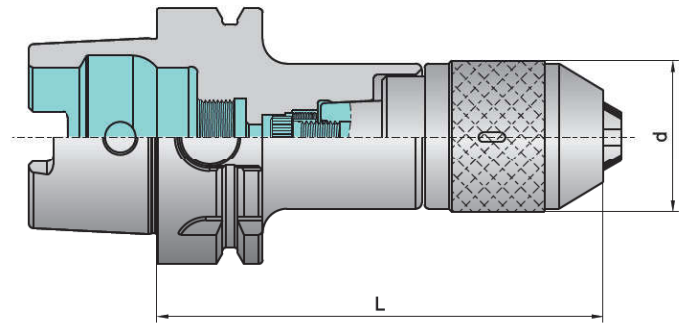

型号 Type	库存 Stock	锥柄型式 Taper type	尺寸(mm) Dimension		夹持范围 Holding range	重量 (kg)
			d	L		
HSK63A-KPU08-130	●	HSK63A	37.5	130	0.5~8	
HSK63A-KPU13-155	●	HSK63A	50.5	155	0.5~13	
HSK63A-KPU16-160	●	HSK63A	57	160	3~16	

订货示例: HSK63A-KPU08-130

- 常备库存 Unallocated stock
- 可备库存 Available stock
- 订单生产 Order production

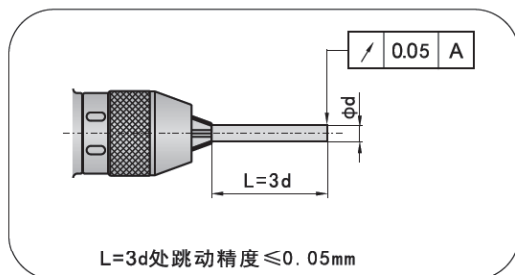

D 工具系统 Tool System

整体式钻夹头刀柄-HSK100A
Integral Drill Chucks

DIN
69893

Form
A

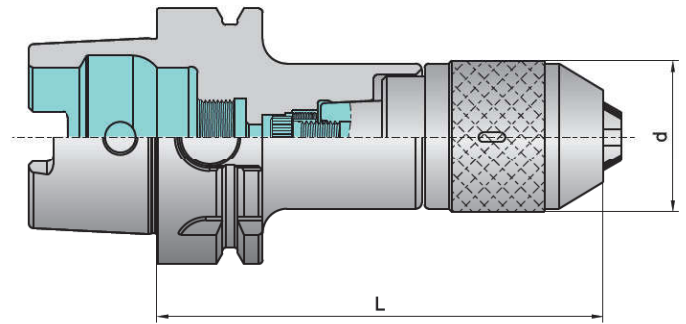

型号 Type	库存 Stock	锥柄型式 Taper type	尺寸(mm) Dimension		夹持范围 Holding range	重量 (kg)
			d	L		
HSK100A-KPU08-135	●	HSK100A	37.5	135	0.5~8	
HSK100A-KPU13-165	●	HSK100A	50.5	165	0.5~13	
HSK100A-KPU16-170	●	HSK100A	57	170	3~16	

订货示例: HSK100A-KPU08-135

- 常备库存 Unallocated stock
- 可备库存 Available stock
- 订单生产 Order production

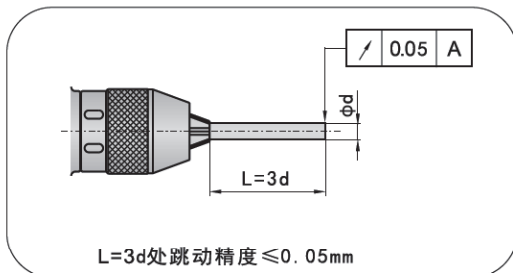

工具系统
热胀工具系统 SHRINK FIT HOLDER
HSK工具系统 HSK TOOL SYSTEM
TMG21工具系统 TMG21 TOOL SYSTEM
7:24工具系统 7:24 TOOL SYSTEM
其它工具系统 SPECIAL TOOL SYSTEM
附件 ACCESSORIES

D 工具系统 Tool System

HSK冷却管扳手 HSK Coolant Wrench

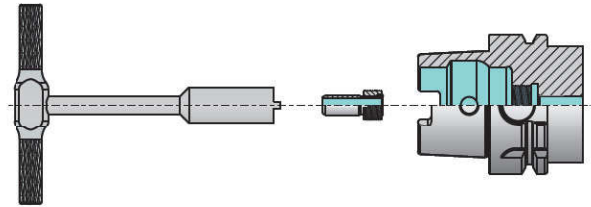
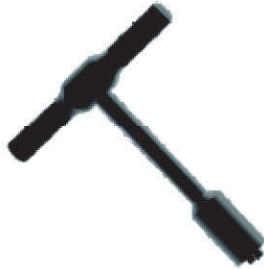

型号 Type	库存 Stock	锥柄型式 Taper type	尺寸(mm) Dimension		重量 (kg)
			d	L1	
WHSK32	●	HSK-32	7.5	107	0.09
WHSK40	●	HSK-40	10.5	112	0.10
WHSK50	●	HSK-50	14.5	117	0.13
WHSK63	●	HSK-63	16.5	122	0.14
WHSK80	●	HSK-80	18	131	0.15
WHSK100	●	HSK-100	22	141	0.19

订货示例WHSK32

HSK冷却管 HSK Coolant Sleeve

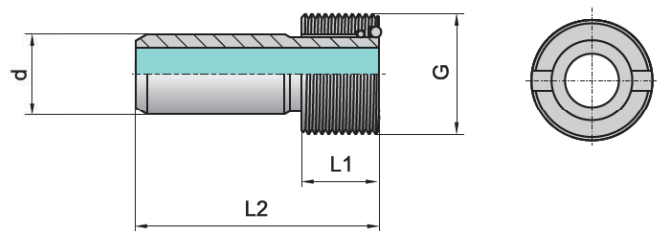

型号 Type	库存 Stock	锥柄型式 Taper type	尺寸(mm) Dimension				重量 (kg)
			G	d	L1	L2	
CHSK32	●	HSK-32	M10x1	6	5.5	26	0.005
CHSK40	●	HSK-40	M12x1	8	7.5	29.5	0.009
CHSK50	●	HSK-50	M16x1	10	9.5	33	0.018
CHSK63	●	HSK-63	M18x1	12	11.5	36.5	0.027
CHSK80	●	HSK-80	M20x1.5	14	13.5	40	0.036
CHSK100	●	HSK-100	M24x1.5	16	15.5	44	0.051

订货示例: CHSK32

● 常备库存 Unallocated stock ● 可备库存 Available stock ○ 订单生产 Order production

D 工具系统 Tool System

HSK主轴清洁棒 HSK Spindle Cleaning Rod

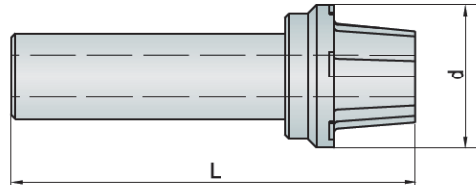

型号 Type	库存 Stock	锥柄型式 Taper type	尺寸(mm) Dimension		重量 (kg)
			d	L	
CLHSK32	●	HSK-32	46	140	
CLHSK40	●	HSK-40	46	145	
CLHSK50	●	HSK-50	55	155	
CLHSK63	●	HSK-63	67	170	
CLHSK80	●	HSK-80	85	180	
CLHSK100	●	HSK-100	105	200	

订货示例CLHSK32

HSK测试棒 HSK Test Rod

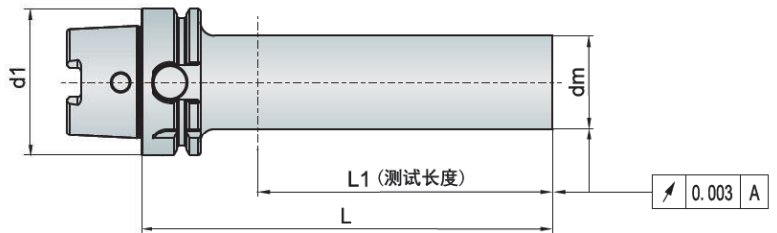

型号 Type	库存 Stock	锥柄型式 Taper type	尺寸(mm) Dimension				重量 (kg)
			d1	dm	L	L1	
HSK63A-TSB40-300	●	HSK-63A	63	40	300	260	3.39
HSK100A-TSB50-350	●	HSK-100A	100	50	350	300	7.02

订货示例: HSK63A-TSB40-300

● 常备库存 Unallocated stock ● 可备库存 Available stock ○ 订单生产 Order production

D 工具系统 Tool System

TMG21模块工具系统配置图

TMG21 Module Tool System Configuration Diagram



专用接口
Special Interface

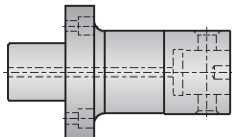

主柄
Main Handle

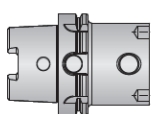

主柄
Main Handle

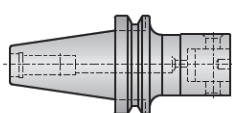

变径模块
Modular Reducer

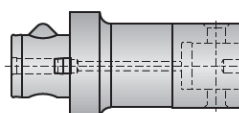

等径模块
Modular Extension



等径模块
Modular Extension

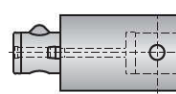

SMB小孔径微调精镗刀
SMB Micro-Adjustable Boring

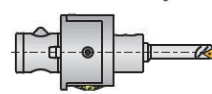

MBQ微调精镗刀
MBQ Micro-Adjustable Boring

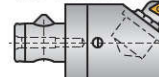

HBM微调精镗刀
HBM Micro-Adjustable Boring

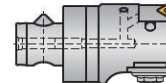

HBA双刃镗刀
HBA Double-edge Boring

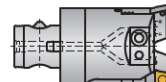

HBH大直径镗刀
HBH Large diameter Boring

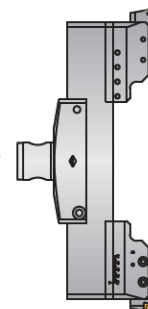

D 工具系统 Tool System

TMG21模块工具系统型号编制 Code System for TMG21 Module Tool System

TMG21手柄模块型号编制说明

21 A. □ □ . □ - □
① ② ③ ④ ⑤ ⑥

- 1、TMG21工具系统。
- 2、A表示此模块为主柄。
- 3、用两个字母表示柄部形式。
- 4、用两位数字表示柄部的锥度代号。
- 5、表示模块联结处的直径。
- 6、表示从圆锥大端直径到前端面的距离。



中间模块型号编制说明

21 B. □ / □ - □
① ② ③ ④ ⑤

- 1、TMG21工具系统。
- 2、B表示此模块为中间模块。
- 3、表示近手柄模块接口模块外径。
- 4、表示近工作模块接口模块外径。
- 5、表示此中间模块的接长长度。

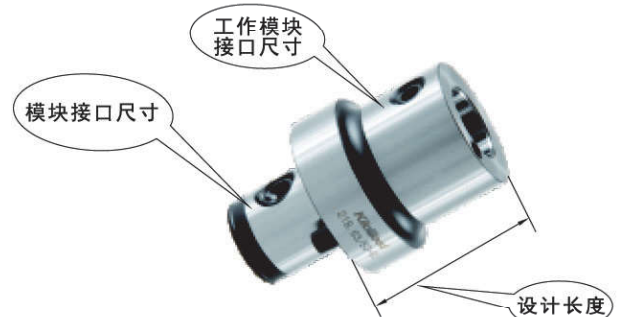

工作模块型号编制说明

21 C. □ - □ - □
① ② ③ ④ ⑤

- 1、TMG21工具系统。
- 2、C表示此模块为工作模块。用来装夹不同的刀具。
- 3、表示模块接口处的外径。
- 4、表示此工作模块的用途。
- 5、表示此工作模块接长长度。

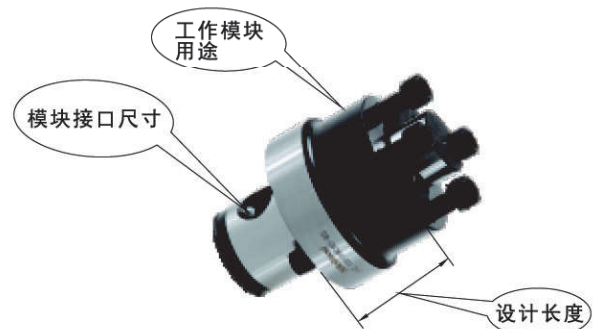

D 工具系统 Tool System

TMG21模块工具系统特点

刚性高，连接强度大。

内锥端螺钉、外锥端螺钉和滑销的锥形模块作用，使模块与主柄紧固连接。

切削扭矩作为扭力施加在主轴上，可使连接部的轴向紧固力提高50%-80%。

高精度。

连接部的重复定位精度可保持在 $2\sim 3\mu\text{m}$ 。

可应用于小直径（ $\phi 20$ ）到大直径（ $\phi 200$ 以上）的广泛领域。

在标准机床上即可使用内部冷却。

采用等径中间模块，可轻松调整刀具长度。

采用变径中间模块，可进行不同直径刀头的安装。

TMG21模块工具系统结构

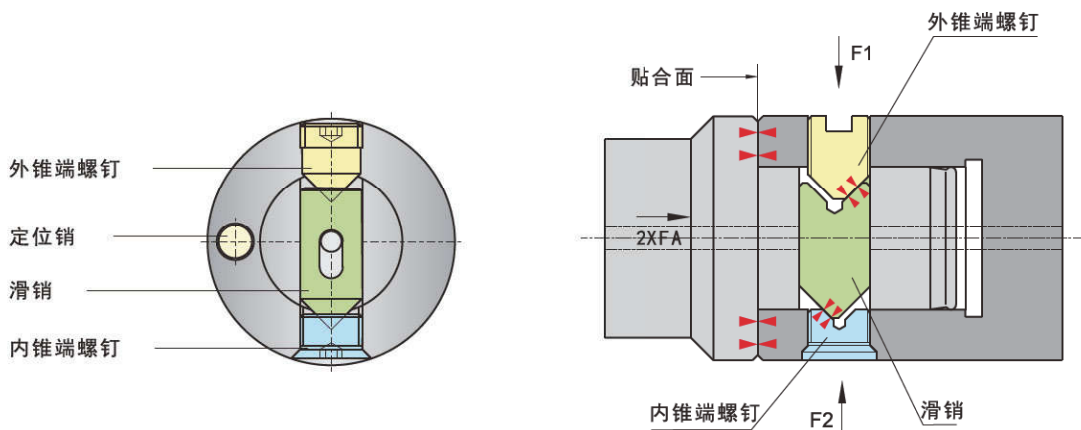

用 F_1 的力拧紧螺钉，滑销沿径向移动，与固定的锥形螺钉相接触，产生反作用力 F_2 。由于内锥端螺钉、外锥端螺钉与滑销的中心之间的偏心，内锥端螺钉与滑销相当于在锥形模块的右侧接触，滑销与外锥端螺钉相当于在锥形模块的左侧接触，接触的位置不在一条直线上。因此，对这个力进行矢量分析，如上图所示，轴向力作用于同一方向，连接力 FA 增至2倍。另外，切削时产生的切削力作为扭力传导出来，使在内锥端螺钉、外锥端螺钉上产生的力 F_1 、 F_2 增大，从而进一步增大连接力 FA 。

D 工具系统 Tool System

TMG21模块手柄HSK63A
TMG21 Modular Arbor

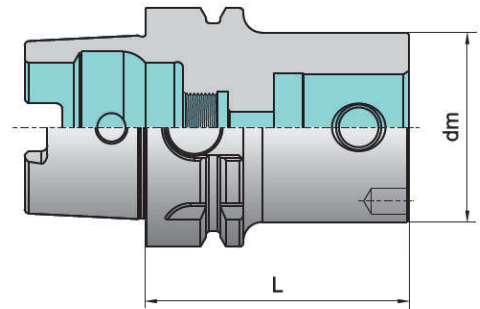
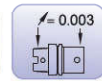

型号 Type	库存 Stock	锥柄型式 Taper type	尺寸(mm) Dimension		外锥端螺钉 Outer taper screw	扳手 Wrench	内锥端螺钉 Inner taper screw	扳手 Wrench	重量 (kg)
			dm	L					
21A.HSK63A.25-50	●	HSK63A	25	50	21A25-E1	S3	21A25-E2	S2	
-100	●	HSK63A	25	100	21A25-E1	S3	21A25-E2	S2	
-130	●	HSK63A	25	130	21A25-E1	S3	21A25-E2	S2	
21A.HSK63A.32-50	●	HSK63A	32	50	21A32-E1	S4	21A32-E2	S2.5	
-85	●	HSK63A	32	85	21A32-E1	S4	21A32-E2	S2.5	
-110	●	HSK63A	32	110	21A32-E1	S4	21A32-E2	S2.5	
-140	●	HSK63A	32	140	21A32-E1	S4	21A32-E2	S2.5	
21A.HSK63A.40-60	●	HSK63A	40	60	21A40-E1	S5	21A40-E2	S3	
-90	●	HSK63A	40	90	21A40-E1	S5	21A40-E2	S3	
-120	●	HSK63A	40	120	21A40-E1	S5	21A40-E2	S3	
-150	●	HSK63A	40	150	21A40-E1	S5	21A40-E2	S3	
21A.HSK63A.50-70	●	HSK63A	50	70	21A50-E1	S6	21A50-E2	S4	
-95	●	HSK63A	50	95	21A50-E1	S6	21A50-E2	S4	
-125	●	HSK63A	50	125	21A50-E1	S6	21A50-E2	S4	
-165	●	HSK63A	50	165	21A50-E1	S6	21A50-E2	S4	
21A.HSK63A.63-80	●	HSK63A	63	80	21A63-E1	S8	21A63-E2	S5	
-105	●	HSK63A	63	105	21A63-E1	S8	21A63-E2	S5	
-145	●	HSK63A	63	145	21A63-E1	S8	21A63-E2	S5	
-180	●	HSK63A	63	180	21A63-E1	S8	21A63-E2	S5	
21A.HSK63A.80-100	●	HSK63A	80	100	21A80-E1	S10	21A80-E2	S6	

订货示例: 21A.HSK63A.25-50

● 常备库存
Unallocated stock

● 可备库存
Available stock

○ 订单生产
Order production

D 工具系统 Tool System

TMG21模块手柄HSK100A
TMG21 Modular Arbor

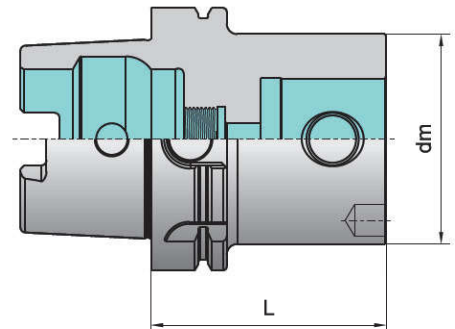
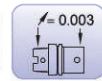

工具系统

SHRINK FIT HOLDER
热胀工具系统

HSK TOOL SYSTEM
HSK工具系统

TMG21 TOOL SYSTEM
TMG21工具系统

7:24 TOOL SYSTEM
7:24工具系统

SPECIAL TOOL SYSTEM
其它工具系统

ACCESSORIES
附件

型号 Type	库存 Stock	锥柄型式 Taper type	尺寸(mm) Dimension		外锥端螺钉 Outer taper screw	扳手 Wrench	内锥端螺钉 Inner taper screw	扳手 Wrench	重量 (kg)
			dm	L					
21A.HSK100A.25-60	●	HSK100A	25	60	21A25-E1	S3	21A25-E2	S2	
-100	●	HSK100A	25	100	21A25-E1	S3	21A25-E2	S2	
-125	●	HSK100A	25	125	21A25-E1	S3	21A25-E2	S2	
-150	●	HSK100A	25	150	21A25-E1	S3	21A25-E2	S2	
21A.HSK100A.32-60	●	HSK100A	32	60	21A32-E1	S4	21A32-E2	S2.5	
-100	●	HSK100A	32	100	21A32-E1	S4	21A32-E2	S2.5	
-130	●	HSK100A	32	130	21A32-E1	S4	21A32-E2	S2.5	
-160	●	HSK100A	32	160	21A32-E1	S4	21A32-E2	S2.5	
-190	●	HSK100A	32	190	21A32-E1	S4	21A32-E2	S2.5	
21A.HSK100A.40-80	●	HSK100A	40	80	21A40-E1	S5	21A40-E2	S3	
-105	●	HSK100A	40	105	21A40-E1	S5	21A40-E2	S3	
-140	●	HSK100A	40	140	21A40-E1	S5	21A40-E2	S3	
-175	●	HSK100A	40	175	21A40-E1	S5	21A40-E2	S3	
-210	●	HSK100A	40	210	21A40-E1	S5	21A40-E2	S3	
21A.HSK100A.50-80	●	HSK100A	50	80	21A50-E1	S6	21A50-E2	S4	
-105	●	HSK100A	50	105	21A50-E1	S6	21A50-E2	S4	
-145	●	HSK100A	50	145	21A50-E1	S6	21A50-E2	S4	
-185	●	HSK100A	50	185	21A50-E1	S6	21A50-E2	S4	
-230	●	HSK100A	50	230	21A50-E1	S6	21A50-E2	S4	
-280	●	HSK100A	50	280	21A50-E1	S6	21A50-E2	S4	

订货示例: 21A.HSK100A.25-60

● 常备库存
Unallocated stock

● 可备库存
Available stock

○ 订单生产
Order production

D 工具系统 Tool System

TMG21模块手柄HSK100A
TMG21 Modular Arbor

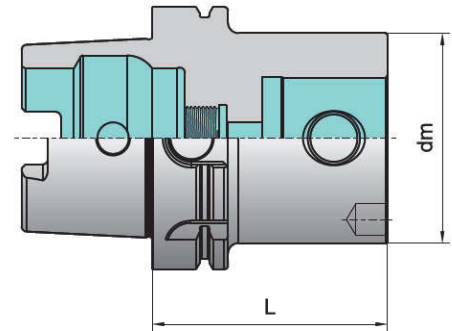
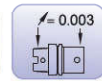

型号 Type	库存 Stock	锥柄型式 Taper type	尺寸(mm) Dimension		外锥端螺钉 Outer taper screw	扳手 Wrench	内锥端螺钉 Inner taper screw	扳手 Wrench	重量 (kg)
			dm	L					
21A.HSK100A.63-80	●	HSK100A	63	80	21A63-E1	S8	21A63-E2	S5	
-120	●	HSK100A	63	120	21A63-E1	S8	21A63-E2	S5	
-165	●	HSK100A	63	165	21A63-E1	S8	21A63-E2	S5	
-210	●	HSK100A	63	210	21A63-E1	S8	21A63-E2	S5	
-260	●	HSK100A	63	260	21A63-E1	S8	21A63-E2	S5	
-310	●	HSK100A	63	310	21A63-E1	S8	21A63-E2	S5	
-360	●	HSK100A	63	360	21A63-E1	S8	21A63-E2	S5	
21A.HSK100A.80-90	●	HSK100A	80	90	21A80-E1	S10	21A80-E2	S6	
-175	●	HSK100A	80	175	21A80-E1	S10	21A80-E2	S6	
-235	●	HSK100A	80	235	21A80-E1	S10	21A80-E2	S6	
-300	●	HSK100A	80	300	21A80-E1	S10	21A80-E2	S6	
-380	●	HSK100A	80	380	21A80-E1	S10	21A80-E2	S6	
21A.HSK100A.100-100	●	HSK100A	100	100	21A100-E1	S12	21A100-E2	S8	
-200	●	HSK100A	100	200	21A100-E1	S12	21A100-E2	S8	

订货示例: 21A.HSK100A.63-80

● 常备库存
Unallocated stock

● 可备库存
Available stock

○ 订单生产
Order production

D 工具系统 Tool System

TMG21模块主柄-BT40
TMG21 Modular Arbor

JIS B
6339

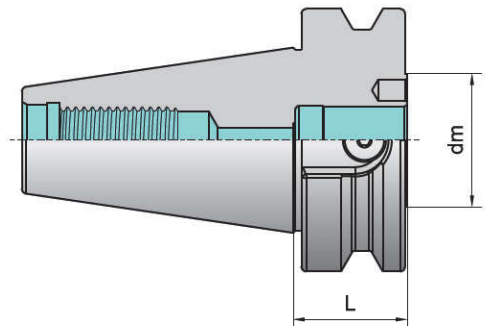
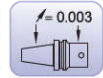

工具系统

SHRINK FIT HOLDER
热胀工具系统

HSK TOOL SYSTEM
HSK工具系统

TMG21 TOOL SYSTEM
TMG21工具系统

7:24 TOOL SYSTEM
7:24工具系统

SPECIAL TOOL SYSTEM
其它工具系统

ACCESSORIES
附件

型号 Type	库存 Stock	锥柄型式 Taper type	尺寸(mm) Dimension		外锥端螺钉 Outer taper screw	扳手 Wrench	内锥端螺钉 Inner taper screw	扳手 Wrench	重量 (kg)
			dm	L					
21A.BT40.25-27.5	○	BT40	25	27.5	21A25-E1	S3	21A25-E2	S2	0.96
21A.BT40.32-27.5	○	BT40	32	27.5	21A32-E1	S4	21A32-E2	S2.5	0.95
21A.BT40.40-27.5	○	BT40	40	27.5	21A40-E1	S5	21A40-E2	S3	0.9
21A.BT50.32-38.5	○	BT50	32	38.5	21A32-E1	S4	21A32-E2	S2.5	3.54
21A.BT50.40-38.5	○	BT50	40	38.5	21A40-E1	S5	21A40-E2	S3	3.5
21A.BT50.50-38.5	○	BT50	50	38.5	21A50-E1	S6	21A50-E2	S4	3.39
21A.BT50.63-38.5	●	BT50	63	38.5	21A63-E1	S8	21A63-E2	S5	3.28

订货示例: 21A.BT40.25-27.5

● 常备库存
Unallocated stock

◐ 可备库存
Available stock

○ 订单生产
Order production

D 工具系统 Tool System

TMG21模块手柄-BT30/BT40
TMG21 Modular Arbor

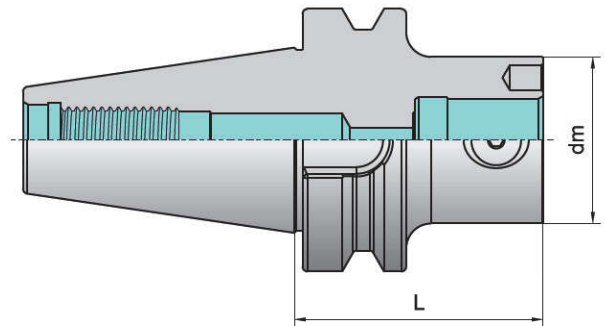
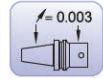

型号 Type	库存 Stock	锥柄型式 Taper type	尺寸(mm) Dimension		外锥端螺钉 Outer taper screw	扳手 Wrench	内锥端螺钉 Inner taper screw	扳手 Wrench	重量 (kg)
			dm	L					
21A.BT30.25-40	○	BT30	25	40	21A25-E1	S3	21A25-E2	S2	0.42
21A.BT30.32-50	○	BT30	32	50	21A32-E1	S4	21A32-E2	S2.5	0.51
21A.BT30.40-50	○	BT30	40	50	21A40-E1	S5	21A40-E2	S3	0.57
21A.BT40.25-60	●	BT40	25	60	21A25-E1	S3	21A25-E2	S2	1.05
-100	●	BT40	25	100	21A25-E1	S3	21A25-E2	S2	1.22
-130	◐	BT40	25	130	21A25-E1	S3	21A25-E2	S2	1.38
21A.BT40.32-60	●	BT40	32	60	21A32-E1	S4	21A32-E2	S2.5	1.1
-85	●	BT40	32	85	21A32-E1	S4	21A32-E2	S2.5	1.24
-110	●	BT40	32	110	21A32-E1	S4	21A32-E2	S2.5	1.43
-140	◐	BT40	32	140	21A32-E1	S4	21A32-E2	S2.5	1.61
21A.BT40.40-60	●	BT40	40	60	21A40-E1	S5	21A40-E2	S3	1.2
-90	●	BT40	40	90	21A40-E1	S5	21A40-E2	S3	1.47
-120	●	BT40	40	120	21A40-E1	S5	21A40-E2	S3	1.75
-150	◐	BT40	40	150	21A40-E1	S5	21A40-E2	S3	2.02
21A.BT40.50-60	●	BT40	50	60	21A50-E1	S6	21A50-E2	S4	1.26
-95	●	BT40	50	95	21A50-E1	S6	21A50-E2	S4	1.74
-125	●	BT40	50	125	21A50-E1	S6	21A50-E2	S4	2.22
-165	◐	BT40	50	165	21A50-E1	S6	21A50-E2	S4	2.7
21A.BT40.63-70	●	BT40	63	70	21A63-E1	S8	21A63-E2	S5	1.66
-105	◐	BT40	63	105	21A63-E1	S8	21A63-E2	S5	2.41
-145	◐	BT40	63	145	21A63-E1	S8	21A63-E2	S5	3.16
-180	●	BT40	63	180	21A63-E1	S8	21A63-E2	S5	3.97

订货示例: 21A.BT30.25-40

● 常备库存 Unallocated stock

◐ 可备库存 Available stock

○ 订单生产 Order production

D 工具系统 Tool System

TMG21模块手柄-BT50
TMG21 Modular Arbor

JIS B
6339

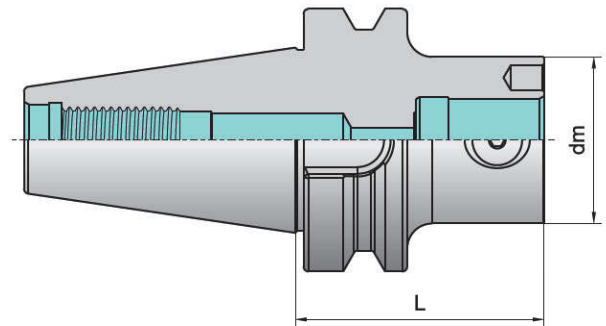
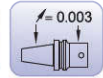

工具系统

SHRINK FIT HOLDER
热胀工具系统

HSK TOOL SYSTEM
HSK工具系统

TMG21 TOOL SYSTEM
TMG21工具系统

Z24 TOOL SYSTEM
7:24工具系统

SPECIAL TOOL SYSTEM
其它工具系统

ACCESSORIES
附件

型号 Type	库存 Stock	锥柄型式 Taper type	尺寸(mm) Dimension		外锥端螺钉	扳手	内锥端螺钉	扳手	重量 (kg)
			dm	L					
21A.BT50.25-70	●	BT50	25	70	21A25-E1	S3	21A25-E2	S2	3.6
-100	◐	BT50	25	100	21A25-E1	S3	21A25-E2	S2	3.72
-125	●	BT50	25	125	21A25-E1	S3	21A25-E2	S2	3.87
-150	◐	BT50	25	150	21A25-E1	S3	21A25-E2	S2	3.99
21A.BT50.32-70	●	BT50	32	70	21A32-E1	S4	21A32-E2	S2.5	3.67
-100	◐	BT50	32	100	21A32-E1	S4	21A32-E2	S2.5	3.87
-130	●	BT50	32	130	21A32-E1	S4	21A32-E2	S2.5	4.07
-160	◐	BT50	32	160	21A32-E1	S4	21A32-E2	S2.5	4.27
-190	◐	BT50	32	190	21A32-E1	S4	21A32-E2	S2.5	4.47
21A.BT50.40-70	●	BT50	40	70	21A40-E1	S5	21A40-E2	S3	3.74
-105	◐	BT50	40	105	21A40-E1	S5	21A40-E2	S3	4.09
-140	●	BT50	40	140	21A40-E1	S5	21A40-E2	S3	4.45
-175	◐	BT50	40	175	21A40-E1	S5	21A40-E2	S3	4.8
-210	◐	BT50	40	210	21A40-E1	S5	21A40-E2	S3	5.15
21A.BT50.50-70	●	BT50	50	70	21A50-E1	S6	21A50-E2	S4	4.7
-105	◐	BT50	50	105	21A50-E1	S6	21A50-E2	S4	4.81
-145	●	BT50	50	145	21A50-E1	S6	21A50-E2	S4	4.92
-185	◐	BT50	50	185	21A50-E1	S6	21A50-E2	S4	5.03
-230	◐	BT50	50	230	21A50-E1	S6	21A50-E2	S4	5.14
-280	○	BT50	50	280	21A50-E1	S6	21A50-E2	S4	5.25

订货示例: 21A.BT50.25-70

● 常备库存
Unallocated stock

◐ 可备库存
Available stock

○ 订单生产
Order production

D 工具系统 Tool System

TMG21模块手柄-BT50
TMG21 Modular Arbor

JIS B
6339

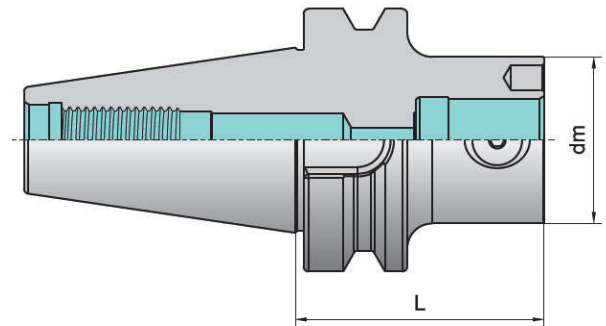
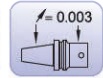

型号 Type	库存 Stock	锥柄型式 Taper type	尺寸(mm) Dimension		外锥端螺钉 Outer taper screw	扳手 Wrench	内锥端螺钉 Inner taper screw	扳手 Wrench	重量 (kg)
			dm	L					
21A.BT50.63-80	●	BT50	63	80	21A63-E1	S8	21A63-E2	S5	4.22
-120	◐	BT50	63	120	21A63-E1	S8	21A63-E2	S5	5.12
-165	●	BT50	63	165	21A63-E1	S8	21A63-E2	S5	6.17
-210	◐	BT50	63	210	21A63-E1	S8	21A63-E2	S5	7.07
-260	◐	BT50	63	260	21A63-E1	S8	21A63-E2	S5	7.92
-310	◐	BT50	63	310	21A63-E1	S8	21A63-E2	S5	8.84
-360	○	BT50	63	360	21A63-E1	S8	21A63-E2	S5	9.71
21A.BT50.80-100	●	BT50	80	100	21A80-E1	S10	21A80-E2	S6	5.28
-175	●	BT50	80	175	21A80-E1	S10	21A80-E2	S6	8.03
-235	◐	BT50	80	235	21A80-E1	S10	21A80-E2	S6	10.78
-300	◐	BT50	80	300	21A80-E1	S10	21A80-E2	S6	13.53
-385	○	BT50	80	385	21A80-E1	S10	21A80-E2	S6	16.38
21A.BT50.100-110	●	BT50	100	110	21A100-E1	S12	21A100-E2	S8	6.54
-200	●	BT50	100	200	21A100-E1	S12	21A100-E2	S8	11.31

订货示例: 21A.BT50.63-80

● 常备库存
Unallocated stock

◐ 可备库存
Available stock

○ 订单生产
Order production

工具系统

热胀工具系统
SHRINK FIT HOLDER

HSK工具系统
HSK TOOL SYSTEM

TMG21工具系统
TMG21 TOOL SYSTEM

7:24工具系统
7/24 TOOL SYSTEM

其它工具系统
SPECIAL TOOL SYSTEM

附件
ACCESSORIES

D 工具系统 Tool System

TMG21模块手柄-JT40
TMG21 Modular Arbor

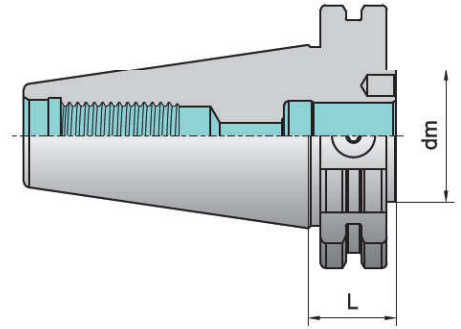

工具系统

SHRINK FIT HOLDER
热胀工具系统

HSK TOOL SYSTEM
HSK工具系统

TMG21 TOOL SYSTEM
TMG21工具系统

7:24 TOOL SYSTEM
7:24工具系统

SPECIAL TOOL SYSTEM
其它工具系统

ACCESSORIES
附件

型号 Type	库存 Stock	锥柄型式 Taper type	尺寸(mm) Dimension		外锥端螺钉 Outer taper screw	扳手 Wrench	内锥端螺钉 Inner taper screw	扳手 Wrench	重量 (kg)
			dm	L					
21A.JT40.25-19.4	○	JT40	25	19.4	21A25-E1	S3	21A25-E2	S2	0.86
21A.JT40.32-21.4	○	JT40	32	21.4	21A32-E1	S4	21A32-E2	S2.5	0.85
21A.JT40.40-22.4	○	JT40	40	22.4	21A40-E1	S5	21A40-E2	S3	0.82
21A.JT40.50-24.4	○	JT40	50	24.4	21A50-E1	S6	21A50-E2	S4	0.8
21A.JT50.25-19.4	○	JT50	25	19.4	21A25-E1	S3	21A25-E2	S2	3.34
21A.JT50.32-21.4	○	JT50	32	21.4	21A32-E1	S4	21A32-E2	S2.5	3.28
21A.JT50.40-22.4	○	JT50	40	22.4	21A40-E1	S5	21A40-E2	S3	3.15
21A.JT50.50-24.4	○	JT50	50	24.4	21A50-E1	S6	21A50-E2	S4	3.06

订货示例: 21A.JT40.25-19.4

● 常备库存
Unallocated stock

◐ 可备库存
Available stock

○ 订单生产
Order production

D 工具系统 Tool System

TMG21模块手柄-JT40/JT50
TMG21 Modular Arbor

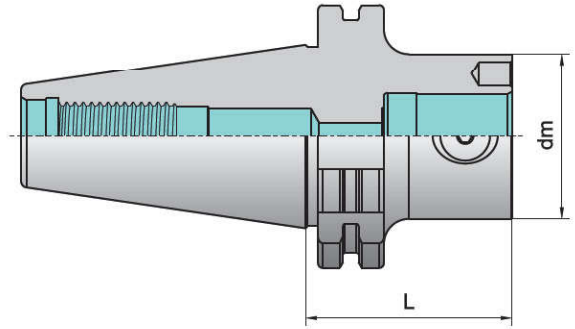

型号 Type	库存 Stock	锥柄型式 Taper type	尺寸(mm) Dimension		外锥端螺钉 Outer taper screw	扳手 Wrench	内锥端螺钉 Inner taper screw	扳手 Wrench	重量 (kg)
			dm	L					
21A.JT40.25-50	○	JT40	25	50	21A25-E1	S3	21A25-E2	S2	0.88
-95	○	JT40	25	95	21A25-E1	S3	21A25-E2	S2	1.09
21A.JT40.32-50	○	JT40	32	50	21A32-E1	S4	21A32-E2	S2.5	0.94
-100	○	JT40	32	100	21A32-E1	S4	21A32-E2	S2.5	1.25
21A.JT40.40-50	○	JT40	40	50	21A40-E1	S5	21A40-E2	S3	1.01
-110	○	JT40	40	110	21A40-E1	S5	21A40-E2	S3	1.59
21A.JT40.50-50	●	JT40	50	50	21A50-E1	S6	21A50-E2	S4	1.1
-115	○	JT40	50	115	21A50-E1	S6	21A50-E2	S4	1.98
21A.JT40.63-90	○	JT40	63	90	21A63-E1	S8	21A63-E2	S5	2
-175	○	JT40	63	175	21A63-E1	S8	21A63-E2	S5	3.19
21A.JT50.25-60	●	JT50	25	60	21A25-E1	S3	21A25-E2	S2	2.67
-105	○	JT50	25	105	21A25-E1	S3	21A25-E2	S2	2.9
21A.JT50.32-60	●	JT50	32	60	21A32-E1	S4	21A32-E2	S2.5	2.76
-110	●	JT50	32	110	21A32-E1	S4	21A32-E2	S2.5	3.1
21A.JT50.40-60	●	JT50	40	60	21A40-E1	S5	21A40-E2	S3	2.86
-120	●	JT50	40	120	21A40-E1	S5	21A40-E2	S3	3.54
21A.JT50.50-60	●	JT50	50	60	21A50-E1	S6	21A50-E2	S4	3
-125	●	JT50	50	125	21A50-E1	S6	21A50-E2	S4	3.96
21A.JT50.63-60	●	JT50	63	60	21A63-E1	S8	21A63-E2	S5	3.24
-145	●	JT50	63	145	21A63-E1	S8	21A63-E2	S5	5.15
21A.JT50.80-70	●	JT50	80	70	21A80-E1	S10	21A80-E2	S6	3.86
-155	●	JT50	80	155	21A80-E1	S10	21A80-E2	S6	6.99
21A.JT50.100-115	●	JT50	100	115	21A100-E1	S12	21A100-E2	S8	6.59
-200	○	JT50	100	200	21A100-E1	S12	21A100-E2	S8	9.77
21A.JT50.125-145	○	JT50	125	145	21A125-E1	S14	21A125-E2	S10	7.62

订货示例: 21A.JT40.25-50

● 常备库存
Unallocated stock

● 可备库存
Available stock

○ 订单生产
Order production

工具系统
热胀工具系统
SHRINK FIT HOLDER
HSK工具系统
HSK TOOL SYSTEM
TMG21工具系统
TMG21 TOOL SYSTEM
7:24工具系统
7/24 TOOL SYSTEM
其它工具系统
SPECIAL TOOL SYSTEM
附件
ACCESSORIES

D 工具系统 Tool System

等径中间模块 Modular Extension

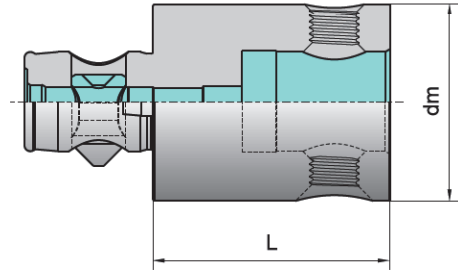

工具系统

SHRINK FIT HOLDER
热胀工具系统

HSK TOOL SYSTEM
HSK工具系统

TMG21 TOOL SYSTEM
TMG21工具系统

7:24 TOOL SYSTEM
7:24工具系统

SPECIAL TOOL SYSTEM
其它工具系统

ACCESSORIES
附件

型号 Type	库存 Stock	尺寸(mm) Dimension		外锥端螺钉 Outertaperscrew	扳手 Wrench	内锥端螺钉 Innertaperscrew	扳手 Wrench	滑销 Slide pin	定位销 Location pin	冷却管 Coolanthose	重量 (kg)
		dm	L								
21B.25/25-45	●	25	45	21A25-E1	S3	21A25-E2	S2	21A25-E3	21A25-E4	21A25-E6	0.19
-60	●	25	60	21A25-E1	S3	21A25-E2	S2	21A25-E3	21A25-E4	21A25-E6	0.22
21B.32/32-35	●	32	35	21A32-E1	S4	21A32-E2	S2.5	21A32-E3	21A32-E4	21A32-E6	0.21
-50	●	32	50	21A32-E1	S4	21A32-E2	S2.5	21A32-E3	21A32-E4	21A32-E6	0.3
-70	●	32	70	21A32-E1	S4	21A32-E2	S2.5	21A32-E3	21A32-E4	21A32-E6	0.42
21B.40/40-40	●	40	40	21A40-E1	S5	21A40-E2	S3	21A40-E3	21A40-E4	21A40-E6	0.37
-60	●	40	60	21A40-E1	S5	21A40-E2	S3	21A40-E3	21A40-E4	21A40-E6	0.56
-90	●	40	90	21A40-E1	S5	21A40-E2	S3	21A40-E3	21A40-E4	21A40-E6	0.86
21B.50/50-50	●	50	50	21A50-E1	S6	21A50-E2	S4	21A50-E3	21A50-E4	21A50-E6	0.72
-65	●	50	65	21A50-E1	S6	21A50-E2	S4	21A50-E3	21A50-E4	21A50-E6	0.95
-100	●	50	100	21A50-E1	S6	21A50-E2	S4	21A50-E3	21A50-E4	21A50-E6	1.47
-150	●	50	150	21A50-E1	S6	21A50-E2	S4	21A50-E3	21A50-E4	21A50-E6	2.23
21B.63/63-60	●	63	60	21A63-E1	S8	21A63-E2	S5	21A63-E3	21A63-E4	21A63-E6	1.38
-85	●	63	85	21A63-E1	S8	21A63-E2	S5	21A63-E3	21A63-E4	21A63-E6	1.98
-125	●	63	125	21A63-E1	S8	21A63-E2	S5	21A63-E3	21A63-E4	21A63-E6	2.93
-190	○	63	190	21A63-E1	S8	21A63-E2	S5	21A63-E3	21A63-E4	21A63-E6	4.98
21B.80/80-70	●	80	70	21A80-E1	S10	21A80-E2	S6	21A80-E3	21A80-E4	21A80-E6	2.59
-85	●	80	85	21A80-E1	S10	21A80-E2	S6	21A80-E3	21A80-E4	21A80-E6	3.16
-125	●	80	125	21A80-E1	S10	21A80-E2	S6	21A80-E3	21A80-E4	21A80-E6	4.69
-240	○	80	240	21A80-E1	S10	21A80-E2	S6	21A80-E3	21A80-E4	21A80-E6	9.13
21B.100/100-85	○	100	85	21A100-E1	S12	21A100-E2	S8	21A100-E3	21A100-E4	21A100-E6	4.91
-125	●	100	125	21A100-E1	S12	21A100-E2	S8	21A100-E3	21A100-E4	21A100-E6	7.32
-160	○	100	160	21A100-E1	S12	21A100-E2	S8	21A100-E3	21A100-E4	21A100-E6	9.43
21B.125/125-160	○	125	160	21A125-E1	S14	21A125-E2	S10	21A125-E3	21A125-E4	21A125-E6	14.7
-200	○	125	200	21A125-E1	S14	21A125-E2	S10	21A125-E3	21A125-E4	21A125-E6	18.46

订货示例: 21B.25/25-45

● 常备库存
Unallocated stock

◐ 可备库存
Available stock

○ 订单生产
Order production

D 工具系统 Tool System

变径中间模块 Modular Reducer

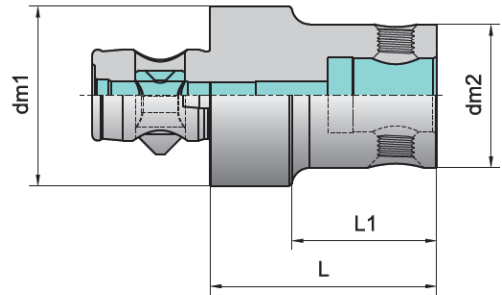

型号 Type	库存 Stock	尺寸(mm) Dimension				外锥端螺钉 Outer taper screw	扳手 Wrench	内锥端螺钉 Inner taper screw	扳手 Wrench	滑销 Slide pin	定位销 Location pin	冷却管 Coolant hose	重量 (kg)
		dm1	dm2	L1	L								
21B.32/25-40	●	32	25	30	40	21A25-E1	S3	21A25-E2	S2	21A32-E3	21A32-E4	21A32-E6	0.18
21B.40/25-40	●	40	25	28	40	21A25-E1	S3	21A25-E2	S2	21A40-E3	21A40-E4	21A40-E6	0.26
21B.40/32-40	●	40	32	28	40	21A32-E1	S4	21A32-E2	S2.5	21A40-E3	21A40-E4	21A40-E6	0.3
21B.50/25-50	●	50	25	35	50	21A25-E1	S3	21A25-E2	S2	21A50-E3	21A50-E4	21A50-E6	0.49
21B.50/32-50	●	50	32	35	50	21A32-E1	S4	21A32-E2	S2.5	21A50-E3	21A50-E4	21A50-E6	0.54
21B.50/40-50	●	50	40	35	50	21A40-E1	S5	21A40-E2	S3	21A50-E3	21A50-E4	21A50-E6	0.63
21B.63/25-60	●	63	25	40	60	21A25-E1	S3	21A25-E2	S2	21A63-E3	21A63-E4	21A63-E6	0.88
21B.63/32-60	●	63	32	40	60	21A32-E1	S4	21A32-E2	S2.5	21A63-E3	21A63-E4	21A63-E6	0.96
21B.63/40-60	●	63	40	40	60	21A40-E1	S5	21A40-E2	S3	21A63-E3	21A63-E4	21A63-E6	1.05
21B.63/50-60	●	63	50	40	60	21A50-E1	S6	21A50-E2	S4	21A63-E3	21A63-E4	21A63-E6	1.17
21B.80/32-60	●	80	32	35	60	21A32-E1	S4	21A32-E2	S2.5	21A80-E3	21A80-E4	21A80-E6	1.56
21B.80/40-60	○	80	40	35	60	21A40-E1	S5	21A40-E2	S3	21A80-E3	21A80-E4	21A80-E6	1.67
21B.80/50-60	●	80	50	35	60	21A50-E1	S6	21A50-E2	S4	21A80-E3	21A80-E4	21A80-E6	1.78
21B.80/63-60	●	80	63	35	60	21A63-E1	S8	21A63-E2	S5	21A80-E3	21A80-E4	21A80-E6	1.98
21B.100/40-80	○	100	40	50	80	21A40-E1	S5	21A40-E2	S3	21A100-E3	21A100-E4	21A100-E6	2.99
21B.100/50-80	○	100	50	50	80	21A50-E1	S6	21A50-E2	S4	21A100-E3	21A100-E4	21A100-E6	3.18
21B.100/63-80	○	100	63	50	80	21A63-E1	S8	21A63-E2	S5	21A100-E3	21A100-E4	21A100-E6	3.58
21B.100/80-80	●	100	80	50	80	21A80-E1	S10	21A80-E2	S6	21A100-E3	21A100-E4	21A100-E6	4.03
21B.125/40-100	○	125	40	50	100	21A40-E1	S5	21A40-E2	S3	21A125-E3	21A125-E4	21A125-E6	5.6
21B.125/50-100	○	125	50	50	100	21A50-E1	S6	21A50-E2	S4	21A125-E3	21A125-E4	21A125-E6	5.88
21B.125/63-100	○	125	63	50	100	21A63-E1	S8	21A63-E2	S5	21A125-E3	21A125-E4	21A125-E6	6.37
21B.125/80-100	○	125	80	50	100	21A80-E1	S10	21A80-E2	S6	21A125-E3	21A125-E4	21A125-E6	7.07
21B.125/100-100	○	125	100	50	100	21A100-E1	S12	21A100-E2	S8	21A125-E3	21A125-E4	21A125-E6	7.91

订货示例: 21B.32/25-40

● 常备库存
Unallocated stock

● 可备库存
Available stock

○ 订单生产
Order production



D 工具系统 Tool System

锥柄标准

锥柄型式 (DIN69871-A)

JT30

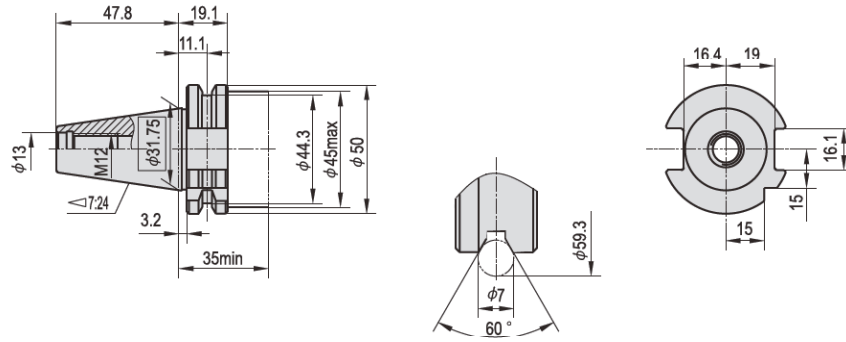

JT40

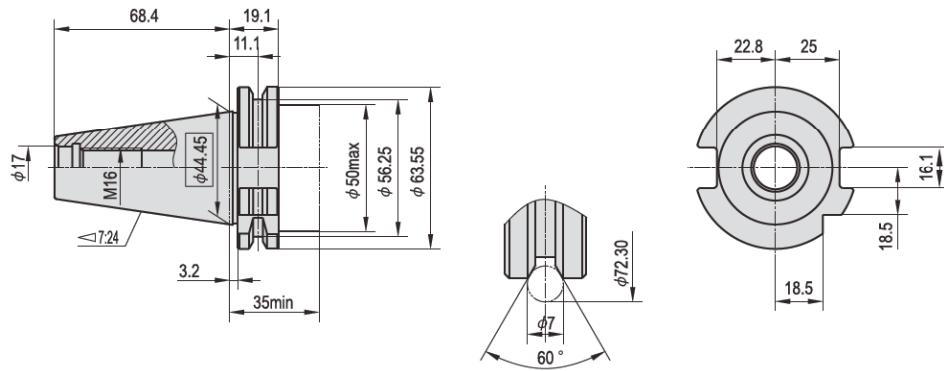

JT50

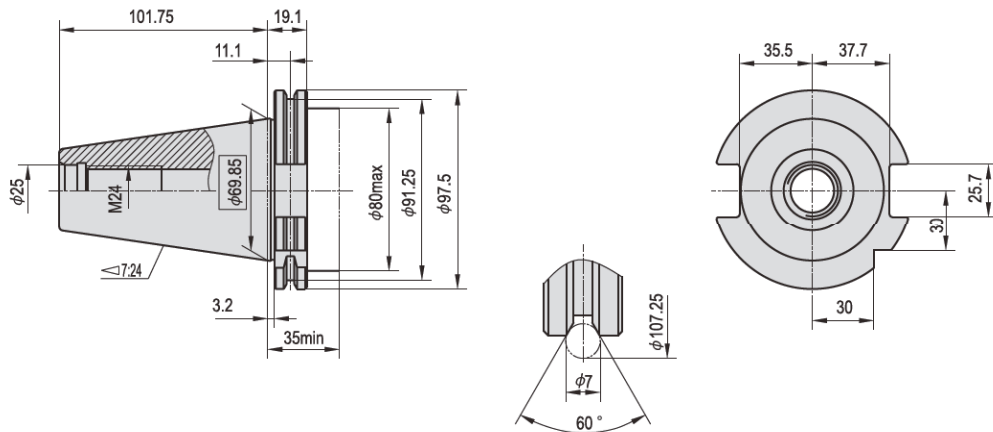

D 工具系统 Tool System

锥柄标准

锥柄型式 (DIN69871-B)

JT30B

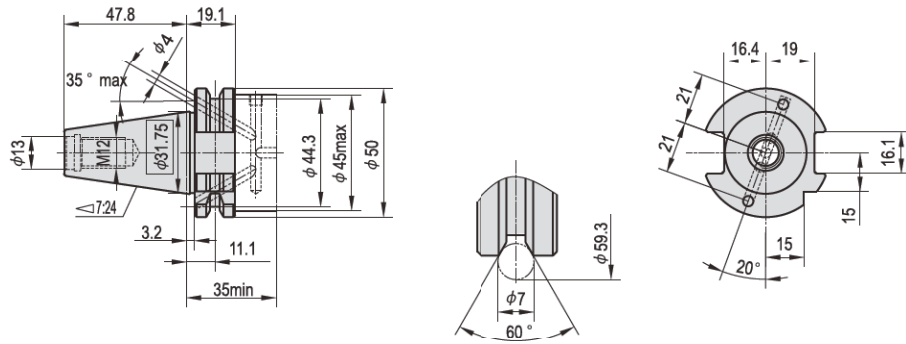

JT40B

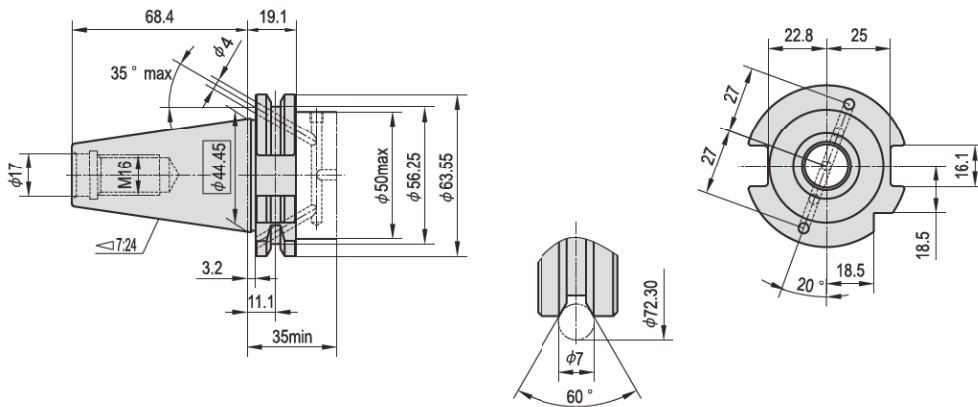

JT50B

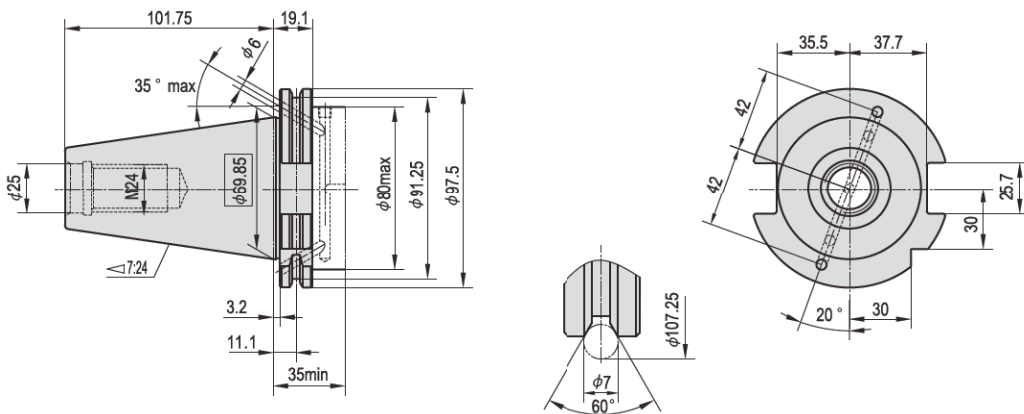

工具系统

SHRINK FIT HOLDER
热胀工具系统

HSK TOOL SYSTEM
HSK工具系统

TMG21 TOOL SYSTEM
TMG21工具系统

7:24 TOOL SYSTEM
7:24工具系统

SPECIAL TOOL SYSTEM
其它工具系统

ACCESSORIES
附件

D 工具系统 Tool System

锥柄标准

锥柄型式 (MAS403BT)

BT30

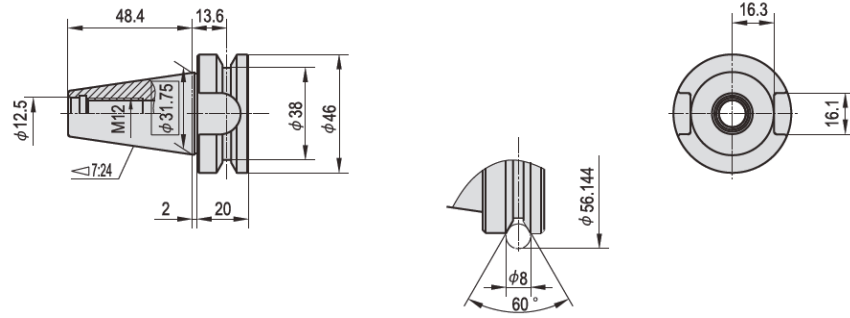

BT40

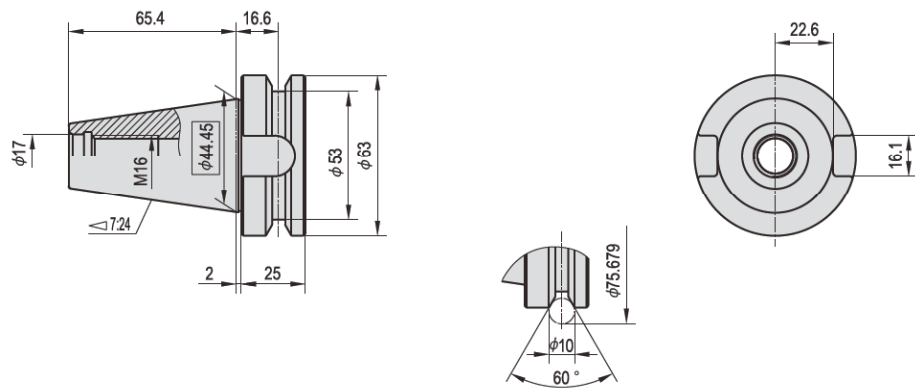

BT50

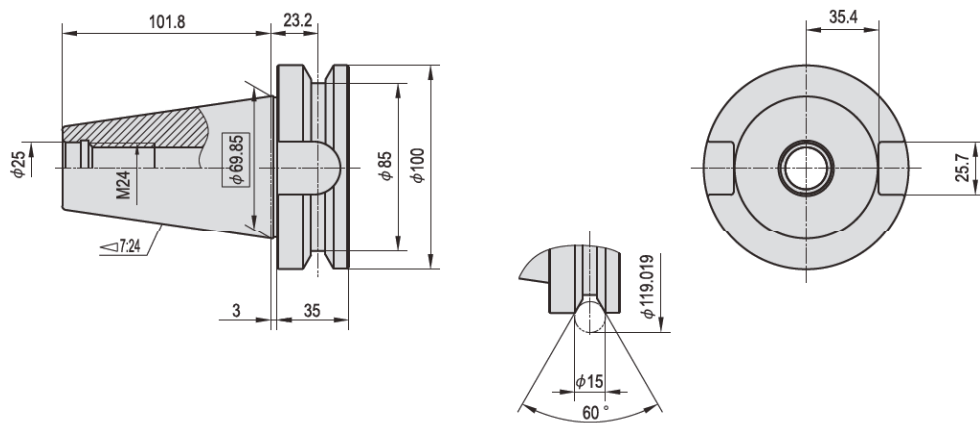

工具系统
热胀工具系统
SHRINK FIT HOLDER
HSK工具系统
HSK TOOL SYSTEM
TMG21工具系统
TMG21 TOOL SYSTEM
7:24工具系统
7:24 TOOL SYSTEM
其它工具系统
SPECIAL TOOL SYSTEM

附件
ACCESSORIES

D 工具系统 Tool System

锥柄标准

锥柄型式 (DIN2080)

ST40

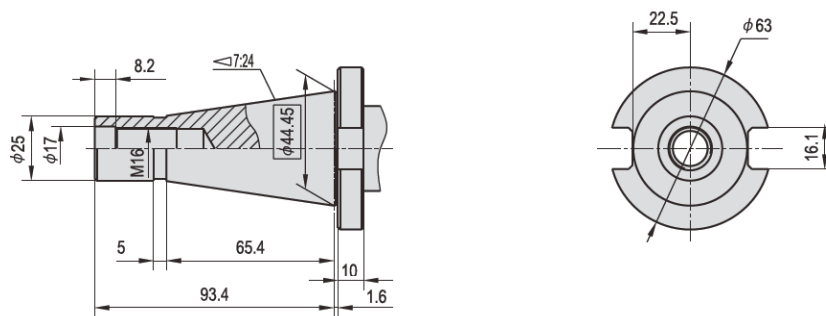

ST50

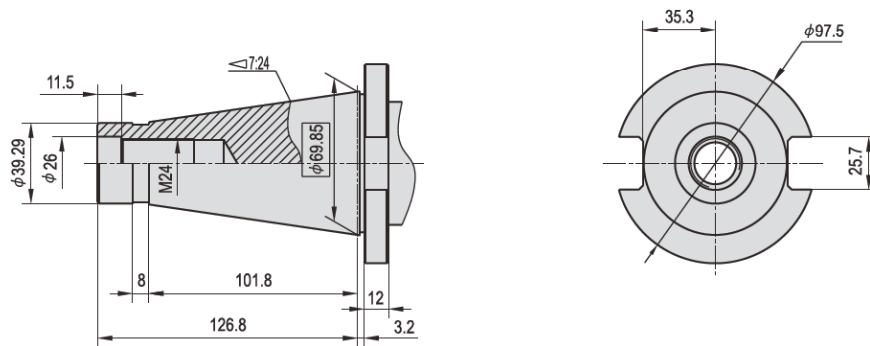

工具系统

SHRINK FIT HOLDER
热胀工具系统

HSK TOOL SYSTEM
HSK工具系统

TMG21 TOOL SYSTEM
TMG21工具系统

7:24 TOOL SYSTEM
7:24工具系统

SPECIAL TOOL SYSTEM
其它工具系统

ACCESSORIES
附件

D 工具系统 Tool System

GSK弹簧夹头刀柄 GSK Collet Chucks

说明:

高品质 Superior quality

秉承Kilowood刀具优良品质，锥柄精度不大于AT3级，
Adhering to the excellent quality of Kilowood cutting tool, taper shank accuracy grade is less than AT3
全体表面镀镍处理，内部冷却
Nickel Plating, internal cooling system

高转速 High speed

转速20000r/min，旋转动平衡G 2.5
Balancing quality: G 2.5 20000 rev./min

高刚性 High rigidity

8°的锥角设计，使夹紧力更大，在高速加工中更加稳定
The design of 8 DEG, the clamping force is larger, more stable in high speed machining

高精度 High precision

4倍长径比处跳动不超过0.005mm
Runout is less than 0.005mm with 4×d



夹紧力强

Strong clamping force

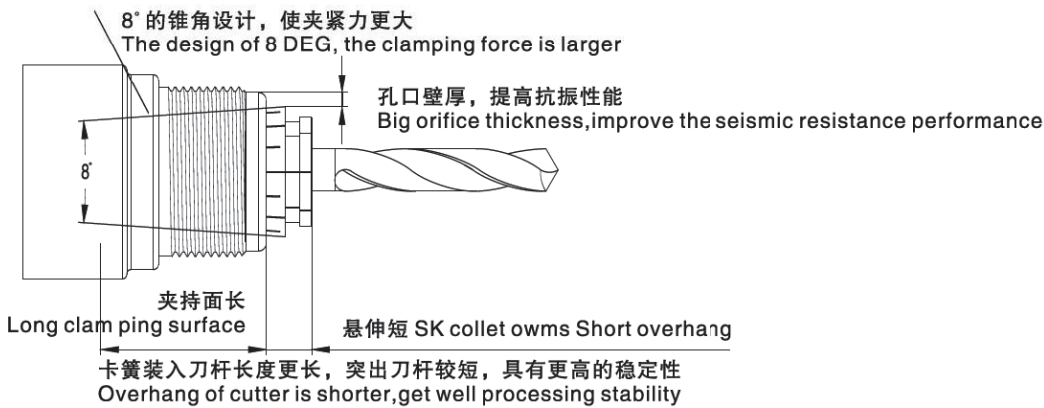

高品质刀柄

High quality knife handle

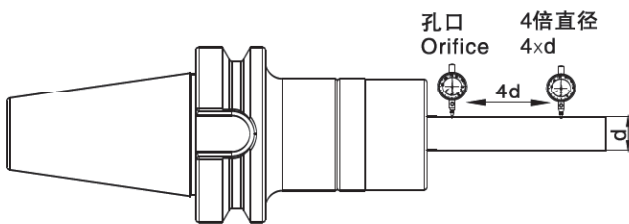

Runout is less than 0.005mm with 4×d

刀柄由高速磨床磨削，采用标准的气动电感量仪检测，接触面积率在90%以上

Tool surface is ground by high speed grind machine, inspected by standard stream taper tester, contact area more than 90%

刀柄内锥跳动≤0.003mm，综合跳动在4倍径中≤0.005mm
Runout of internal cone is less than 0.003mm, comprehensive runout is less than 0.005mm with 4×d

D 工具系统 Tool System

多用途加工 Multipurpose Processing

可进行钻、铣、铰、攻丝等加工

Drilling, milling, ream, tapping and other machining

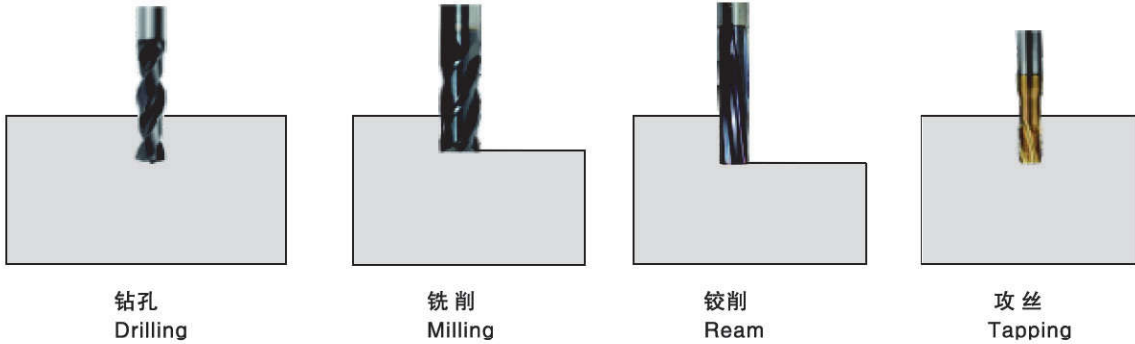

钻孔
Drilling

铣削
Milling

铰削
Ream

攻丝
Tapping

SK卡簧装夹方法:

Clamping method for SK collet



将卡簧装入卡簧拆卸器中，然后装入螺母
Put SK collet into collet puller, then throw collet into nut



按图示方法将卡簧拆卸器倾斜，即从螺母中退出卡簧拆卸器，卡簧安装完成
Tilt the collet puller as shown in picture, SK collet and collet was separated

拆卸方法:

Removing method



拆卸时将卡簧拆卸器按入卡簧
Put SK collet into collet puller, push together by appreciate power



在卡簧拆卸器的作用下使卡簧弹性变形，从而将卡簧取出
Big-end of SK collet shranked, collet was removed from nut

D 工具系统 Tool System

GSK弹簧夹头刀柄-BT30
GSK Collet Chucks

JIS B 6339
G2.5 25000/min
 $\nabla = 0.003$
镀镍处理
N
- +

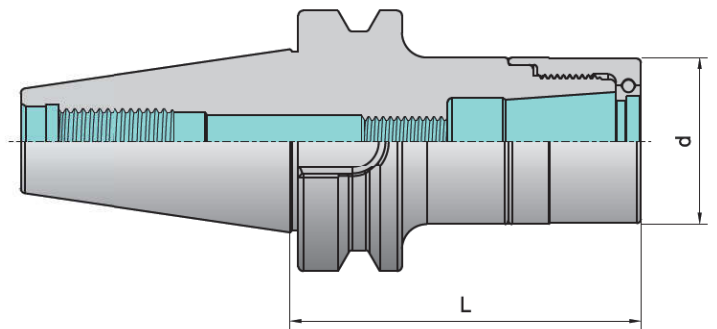

型号 Type	库存 Stock	锥柄型式 Taper type	尺寸(mm) Dimension		螺母 Nut	扳手 Wrench	SK卡簧 SKcollet	卡簧拆卸器 Colletpuller	重量 (kg)
			d	L					
BT30-GSK06-60	●	BT30	20	60	LN-GSK06	WGSK06	SK06	CGSK06	
-90	●	BT30	20	90	LN-GSK06	WGSK06	SK06	CGSK06	
-120	○	BT30	20	120	LN-GSK06	WGSK06	SK06	CGSK06	
BT30-GSK10-60	●	BT30	27.6	60	LN-GSK10	WGSK10	SK10	CGSK10	
-90	●	BT30	27.6	90	LN-GSK10	WGSK10	SK10	CGSK10	
-120	○	BT30	27.6	120	LN-GSK10	WGSK10	SK10	CGSK10	
BT30-GSK16-60	●	BT30	40.5	60	LN-GSK16	WGSK16	SK16	CGSK16	
-90	●	BT30	40.5	90	LN-GSK16	WGSK16	SK16	CGSK16	
-120	○	BT30	40.5	120	LN-GSK16	WGSK16	SK16	CGSK16	

订货示例: BT30-GSK06-60 G2.5 25000rpm

● 常备库存 Unallocated stock
● 可备库存 Available stock
○ 订单生产 Order production

D 工具系统 Tool System

GSK弹簧夹头刀柄-BT40
GSK Collet Chucks

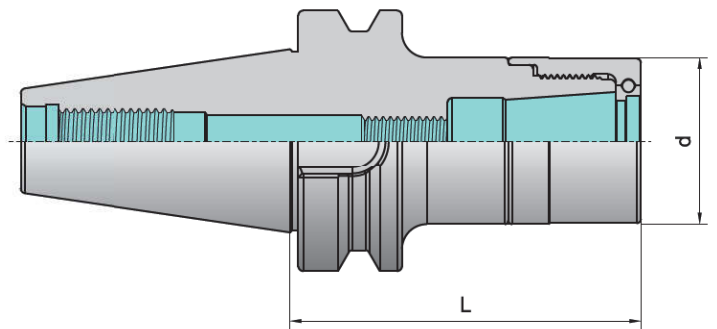

型号 Type	库存 Stock	锥柄型式 Taper type	尺寸(mm) Dimension		螺母 Nut	扳手 Wrench	SK卡簧 SKcollet	卡簧拆卸器 Colletpuller	重量 (kg)
			d	L					
BT40-GSK06-60	●	BT40	20	60	LN-GSK06	WGSK06	SK06	CGSK06	
-90	●	BT40	20	90	LN-GSK06	WGSK06	SK06	CGSK06	
-120	◐	BT40	20	120	LN-GSK06	WGSK06	SK06	CGSK06	
BT40-GSK10-60	●	BT40	27.6	60	LN-GSK10	WGSK10	SK10	CGSK10	
-90	●	BT40	27.6	90	LN-GSK10	WGSK10	SK10	CGSK10	
-120	◐	BT40	27.6	120	LN-GSK10	WGSK10	SK10	CGSK10	
-150	○	BT40	27.6	150	LN-GSK10	WGSK10	SK10	CGSK10	
BT40-GSK16-75	●	BT40	40.5	75	LN-GSK16	WGSK16	SK16	CGSK16	
-90	●	BT40	40.5	90	LN-GSK16	WGSK16	SK16	CGSK16	
-120	◐	BT40	40.5	120	LN-GSK16	WGSK16	SK16	CGSK16	
-150	○	BT40	40.5	150	LN-GSK16	WGSK16	SK16	CGSK16	
BT40-GSK25-90	●	BT40	55.5	90	LN-GSK25	WGSK25	SK25	CGSK25	
-120	◐	BT40	55.5	120	LN-GSK25	WGSK25	SK25	CGSK25	

订货示例: BT40-GSK06-60 G2.5 25000rpm

● 常备库存 Unallocated stock ◐ 可备库存 Available stock ○ 订单生产 Order production

工具系统
热胀工具系统 SHRINK FIT HOLDER
HSK工具系统 HSK TOOL SYSTEM
TMG21工具系统 TMG21 TOOL SYSTEM
7:24工具系统 7:24 TOOL SYSTEM
其它工具系统 SPECIAL TOOL SYSTEM
附件 ACCESSORIES

D 工具系统 Tool System

GSK弹簧夹头刀柄-BT50
GSK Collet Chucks

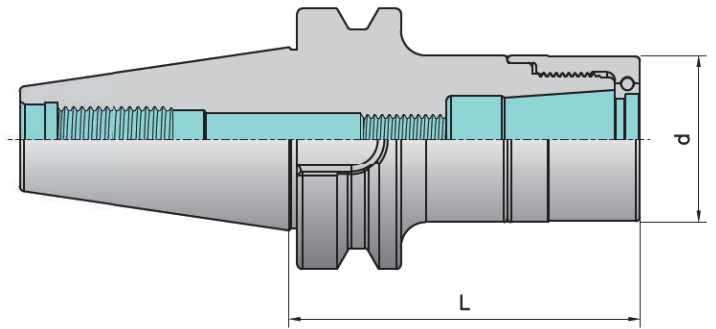

型号 Type	库存 Stock	锥柄型式 Taper type	尺寸(mm) Dimension		螺母 Nut	扳手 Wrench	SK卡簧 SKcollet	卡簧拆卸器 Colletpuller	重量 (kg)
			d	L					
BT50-GSK10-105	●	BT50	27.6	105	LN-GSK10	WGSK10	SK10	CGSK10	
-135	◐	BT50	27.6	135	LN-GSK10	WGSK10	SK10	CGSK10	
-165	○	BT50	27.6	165	LN-GSK10	WGSK10	SK10	CGSK10	
BT50-GSK16-105	●	BT50	40.5	105	LN-GSK16	WGSK16	SK16	CGSK16	
-135	◐	BT50	40.5	135	LN-GSK16	WGSK16	SK16	CGSK16	
-165	○	BT50	40.5	165	LN-GSK16	WGSK16	SK16	CGSK16	
-200	○	BT50	40.5	200	LN-GSK16	WGSK16	SK16	CGSK16	
BT50-GSK25-105	●	BT50	55.5	105	LN-GSK25	WGSK25	SK25	CGSK25	
-135	◐	BT50	55.5	135	LN-GSK25	WGSK25	SK25	CGSK25	
-165	○	BT50	55.5	165	LN-GSK25	WGSK25	SK25	CGSK25	
-200	○	BT50	55.5	200	LN-GSK25	WGSK25	SK25	CGSK25	

订货示例: BT50-GSK10-105 G6.3 8000rpm

● 常备库存 Unallocated stock ◐ 可备库存 Available stock ○ 订单生产 Order production

D 工具系统 Tool System

GSER弹簧夹头刀柄-BT30
GSER Collet Chucks

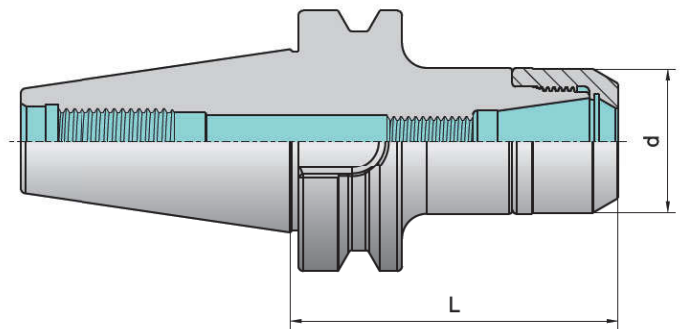
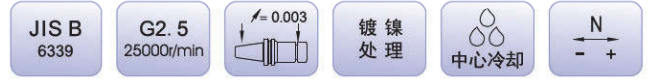

型号 Type	库存 Stock	锥柄型式 TaperType	尺寸(mm) Dimension		螺母 Nut	扳手 Wrench	卡簧 Collet	螺钉 Screw
			d	L				
BT30-GSER16-60	●	BT30	30	60	LN-GSER16	WGSER16	ER16	SGC100150
-90	●	BT30	30	90	LN-GSER16	WGSER16	ER16	SGC100150
-120	○	BT30	30	120	LN-GSER16	WGSER16	ER16	SGC100150
BT30-GSER20-60	●	BT30	35	60	LN-GSER20	WGSER20	ER20	SGC120200
-90	●	BT30	35	90	LN-GSER20	WGSER20	ER20	SGC120200
-120	●	BT30	35	120	LN-GSER20	WGSER20	ER20	SGC120200
BT30-GSER25-60	●	BT30	40	60	LN-GSER25	WGSER25	ER25	SGC160200
-90	●	BT30	40	90	LN-GSER25	WGSER25	ER25	SGC160200
-120	●	BT30	40	120	LN-GSER25	WGSER25	ER25	SGC160200
BT30-GSER32-75	●	BT30	48	75	LN-GSER32	WGSER32	ER32	SGD220250
-90	●	BT30	48	90	LN-GSER32	WGSER32	ER32	SGD220250
-120	●	BT30	48	120	LN-GSER32	WGSER32	ER32	SGD220250

订货示例: BT30-GSER16-60 G2.5 25000rpm

● 常备库存 Unallocated stock ● 可备库存 Available stock ○ 订单生产 Order production

工具系统
热胀工具系统 SHRINK FIT HOLDER
HSK工具系统 HSK TOOL SYSTEM
TMG21工具系统 TMG21 TOOL SYSTEM
7:24工具系统 7:24 TOOL SYSTEM
其它工具系统 SPECIAL TOOL SYSTEM
附件 ACCESSORIES

D 工具系统 Tool System

GSER弹簧夹头刀柄-BT40
GSER Collet Chucks

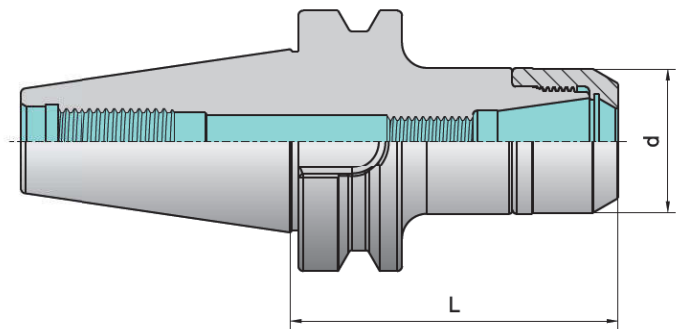
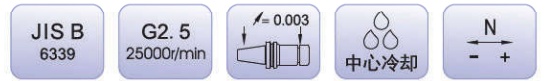

型号 Type	库存 Stock	锥柄型式 TaperType	尺寸(mm) Dimension		螺母 Nut	扳手 Wrench	卡簧 Collet	螺钉 Screw
			d	L				
BT40-GSER16-75	●	BT40	30	75	LN-GSER16	WGSER16	ER16	SGC100150
-90	●	BT40	30	90	LN-GSER16	WGSER16	ER16	SGC100150
-120	●	BT40	30	120	LN-GSER16	WGSER16	ER16	SGC100150
-150	●	BT40	30	150	LN-GSER16	WGSER16	ER16	SGC100150
BT40-GSER20-75	●	BT40	35	75	LN-GSER20	WGSER20	ER20	SGC120200
-90	●	BT40	35	90	LN-GSER20	WGSER20	ER20	SGC120200
-120	●	BT40	35	120	LN-GSER20	WGSER20	ER20	SGC120200
-150	●	BT40	35	150	LN-GSER20	WGSER20	ER20	SGC120200
-200	◐	BT40	35	200	LN-GSER20	WGSER20	ER20	SGC120200
BT40-GSER25-75	●	BT40	40	75	LN-GSER25	WGSER25	ER25	SGC160200
-90	●	BT40	40	90	LN-GSER25	WGSER25	ER25	SGC160200
-120	●	BT40	40	120	LN-GSER25	WGSER25	ER25	SGC160200
-150	●	BT40	40	150	LN-GSER25	WGSER25	ER25	SGC160200
-200	◐	BT40	40	200	LN-GSER25	WGSER25	ER25	SGC160200
BT40-GSER32-75	●	BT40	48	75	LN-GSER32	WGSER32	ER32	SGD220250
-90	●	BT40	48	90	LN-GSER32	WGSER32	ER32	SGD220250
-120	●	BT40	48	120	LN-GSER32	WGSER32	ER32	SGD220250
-150	●	BT40	48	150	LN-GSER32	WGSER32	ER32	SGD220250
-200	◐	BT40	48	200	LN-GSER32	WGSER32	ER32	SGD220250

订货示例: BT40-GSER16-75 G2.5 25000rpm

● 常备库存 Unallocated stock ◐ 可备库存 Available stock ○ 订单生产 Order production

D 工具系统 Tool System

GSER弹簧夹头刀柄-BT50
GSER Collet Chucks

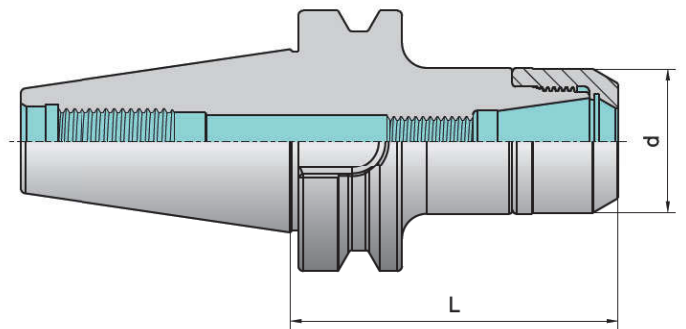
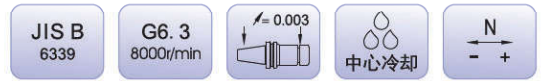

型号 Type	库存 Stock	锥柄型式 TaperType	尺寸(mm) Dimension		螺母 Nut	扳手 Wrench	卡簧 Collet	螺钉 Screw
			d	L				
BT50-GSER16-105	●	BT50	30	105	LN-GSER16	WGSER16	ER16	SGC100150
-135	○	BT50	30	135	LN-GSER16	WGSER16	ER16	SGC100150
-165	○	BT50	30	165	LN-GSER16	WGSER16	ER16	SGC100150
BT50-GSER20-105	●	BT50	35	105	LN-GSER20	WGSER20	ER20	SGC120200
-135	○	BT50	35	135	LN-GSER20	WGSER20	ER20	SGC120200
-165	○	BT50	35	165	LN-GSER20	WGSER20	ER20	SGC120200
BT50-GSER25-105	●	BT50	40	105	LN-GSER25	WGSER25	ER25	SGC160200
-135	○	BT50	40	135	LN-GSER25	WGSER25	ER25	SGC160200
-165	○	BT50	40	165	LN-GSER25	WGSER25	ER25	SGC160200
-200	○	BT50	40	200	LN-GSER25	WGSER25	ER25	SGC160200
BT50-GSER32-105	●	BT50	48	105	LN-GSER32	WGSER32	ER32	SGD220250
-135	○	BT50	48	135	LN-GSER32	WGSER32	ER32	SGD220250
-165	○	BT50	48	165	LN-GSER32	WGSER32	ER32	SGD220250
-200	○	BT50	48	200	LN-GSER32	WGSER32	ER32	SGD220250

订货示例: BT50-GSER16-105 G6.3 8000rpm

● 常备库存 Unallocated stock ● 可备库存 Available stock ○ 订单生产 Order production

工具系统
热胀工具系统 SHRINK FIT HOLDER
HSK工具系统 HSK TOOL SYSTEM
TMG21工具系统 TMG21 TOOL SYSTEM
7:24工具系统 7:24 TOOL SYSTEM
其它工具系统 SPECIAL TOOL SYSTEM
附件 ACCESSORIES

D 工具系统 Tool System

弹簧夹头刀柄-BT30/BT40
ER Collet Chucks

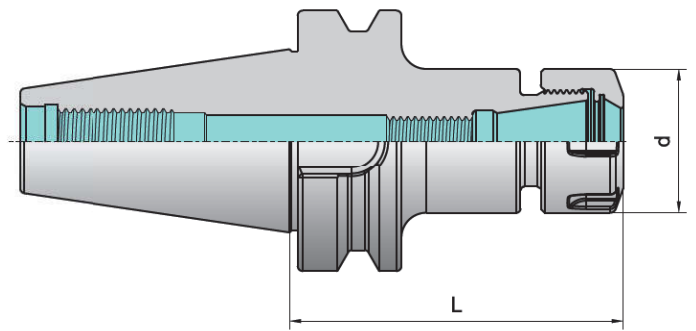
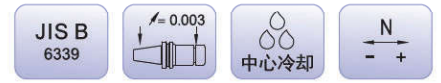

型号 Type	库存 Stock	锥柄型式 Taper type	尺寸(mm) Dimension		螺母 Nut	扳手 Wrench	卡簧 ERcollet	螺钉 Screw	重量 (kg)
			d	L					
BT30-ER11-60	●	BT30	19	60	LN11S	-	ER11	SGC060150	0.44
-100	○	BT30	19	100	LN11S	-	ER11	SGC060150	0.78
BT30-ER16-60	●	BT30	28	60	LN16S	-	ER16	SGC100150	0.54
-100	●	BT30	28	100	LN16S	-	ER16	SGC100150	0.68
BT30-ER20-60	●	BT30	34	60	LN20S	-	ER20	SGC120200	0.55
-100	●	BT30	34	100	LN20S	-	ER20	SGC120200	0.82
BT30-ER25-60	●	BT30	42	60	LN25	WER25	ER25	SGC160200	0.58
-100	●	BT30	42	100	LN25	WER25	ER25	SGC160200	0.98
BT40-ER11-70	●	BT40	19	70	LN11S	-	ER11	SGC060150	1.02
-100	●	BT40	19	100	LN11S	-	ER11	SGC060150	1.10
-160	●	BT40	19	160	LN11S	-	ER11	SGC060150	1.22
-200	●	BT40	19	200	LN11S	-	ER11	SGC060150	1.29
BT40-ER16-70	●	BT40	28	70	LN16S	-	ER16	SGC100150	1.14
-100	●	BT40	28	100	LN16S	-	ER16	SGC100150	1.32
-160	●	BT40	28	160	LN16S	-	ER16	SGC100150	1.63
-200	●	BT40	28	200	LN16S	-	ER16	SGC100150	1.84
BT40-ER20-70	●	BT40	34	70	LN20S	-	ER20	SGC120200	1.16
-100	●	BT40	34	100	LN20S	-	ER20	SGC120200	1.38
-160	●	BT40	34	160	LN20S	-	ER20	SGC120200	1.76
-200	●	BT40	34	200	LN20S	-	ER20	SGC120200	2.02

订货示例: BT30-ER11-60

● 常备库存 Unallocated stock ● 可备库存 Available stock ○ 订单生产 Order production

D 工具系统 Tool System

弹簧夹头刀柄-BT40
ER Collet Chucks

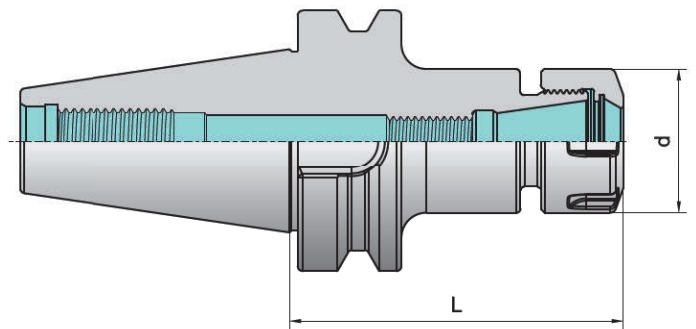
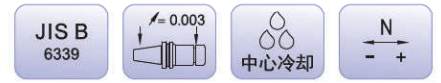

型号 Type	库存 Stock	锥柄型式 Taper type	尺寸(mm) Dimension		螺母 Nut	扳手 Wrench	卡簧 ERcollet	螺钉 Screw	重量 (kg)
			d	L					
BT40-ER25-70	●	BT40	42	70	LN25	WER25	ER25	SGC160200	1.22
-100	●	BT40	42	100	LN25	WER25	ER25	SGC160200	1.52
-160	●	BT40	42	160	LN25	WER25	ER25	SGC160200	2.11
-200	●	BT40	42	200	LN25	WER25	ER25	SGC160200	2.47
BT40-ER32-70	●	BT40	50	70	LN32	WER32	ER32	SGD220250	1.32
-100	●	BT40	50	100	LN32	WER32	ER32	SGD220250	1.72
-160	●	BT40	50	160	LN32	WER32	ER32	SGD220250	2.58
-200	●	BT40	50	200	LN32	WER32	ER32	SGD220250	3.15
BT40-ER40-70	●	BT40	63	70	LN40	WER40	ER40	SGD280250	1.41
-100	●	BT40	63	100	LN40	WER40	ER40	SGD280250	2.01
-160	◐	BT40	63	160	LN40	WER40	ER40	SGD280250	3.29

订货示例: BT40-ER25-70

● 常备库存 Unallocated stock ◐ 可备库存 Available stock ○ 订单生产 Order production

工具系统
热胀工具系统 SHRINK FIT HOLDER
HSK工具系统 HSK TOOL SYSTEM
TMG21工具系统 TMG21 TOOL SYSTEM
7:24工具系统 7:24 TOOL SYSTEM
其它工具系统 SPECIAL TOOL SYSTEM
附件 ACCESSORIES

D 工具系统 Tool System

弹簧夹头刀柄-BT50
ER Collet Chucks

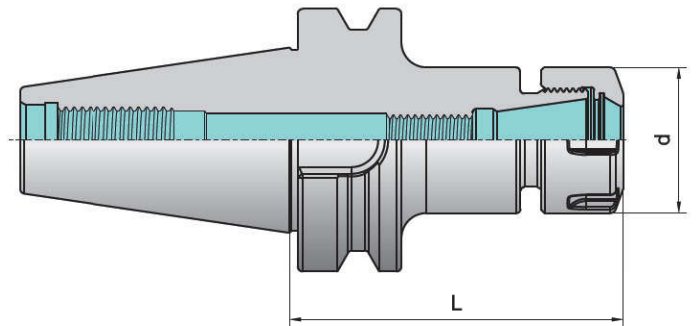
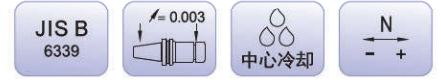

型号 Type	库存 Stock	锥柄型式 Taper type	尺寸(mm) Dimension		螺母 Nut	扳手 Wrench	卡簧 ERcollet	螺钉 Screw	重量 (kg)
			d	L					
BT50-ER11-70	○	BT50	19	70	LN11S	-	ER11	SGC060150	3.56
-100	○	BT50	19	100	LN11S	-	ER11	SGC060150	3.65
-160	◐	BT50	19	160	LN11S	-	ER11	SGC060150	3.78
-200	○	BT50	19	200	LN11S	-	ER11	SGC060150	3.85
BT50-ER16-70	○	BT50	28	70	LN16S	-	ER16	SGC100150	3.64
-100	●	BT50	28	100	LN16S	-	ER16	SGC100150	3.81
-160	●	BT50	28	160	LN16S	-	ER16	SGC100150	4.26
-200	◐	BT50	28	200	LN16S	-	ER16	SGC100150	4.37
BT50-ER20-70	◐	BT50	34	70	LN20S	-	ER20	SGC120200	3.67
-100	●	BT50	34	100	LN20S	-	ER20	SGC120200	3.84
-160	●	BT50	34	160	LN20S	-	ER20	SGC120200	4.34
-200	◐	BT50	34	200	LN20S	-	ER20	SGC120200	4.52
BT50-ER25-70	●	BT50	42	70	LN25	WER25	ER25	SGC160200	3.70
-100	●	BT50	42	100	LN25	WER25	ER25	SGC160200	4.54
-160	●	BT50	42	160	LN25	WER25	ER25	SGC160200	4.74
-200	●	BT50	42	200	LN25	WER25	ER25	SGC160200	5.48
BT50-ER32-70	●	BT50	50	70	LN32	WER32	ER32	SGD220250	3.73
-100	●	BT50	50	100	LN32	WER32	ER32	SGD220250	4.14
-160	●	BT50	50	160	LN32	WER32	ER32	SGD220250	4.97
-200	●	BT50	50	200	LN32	WER32	ER32	SGD220250	5.48
BT50-ER40-70	●	BT50	63	70	LN40	WER40	ER40	SGD280250	3.76
-100	●	BT50	63	100	LN40	WER40	ER40	SGD280250	4.44
-160	●	BT50	63	160	LN40	WER40	ER40	SGD280250	5.77
-200	●	BT50	63	200	LN40	WER40	ER40	SGD280250	6.66

订货示例: BT50-ER11-70

● 常备库存 Unallocated stock ◐ 可备库存 Available stock ○ 订单生产 Order production

D 工具系统 Tool System

弹簧夹头刀柄-JT40
ER Collet Chucks

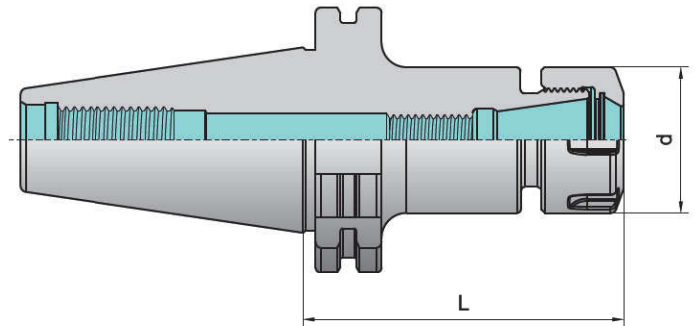
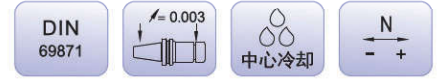

型号 Type	库存 Stock	锥柄型式 Taper type	尺寸(mm) Dimension		螺母 Nut	扳手 Wrench	卡簧 ERcollet	螺钉 Screw	重量 (kg)
			d	L					
JT40-ER11-70	○	JT40	19	70	LN11S	-	ER11	SGC060150	0.9
-100	○	JT40	19	100	LN11S	-	ER11	SGC060150	0.95
-160	○	JT40	19	160	LN11S	-	ER11	SGC060150	1.10
-200	○	JT40	19	200	LN11S	-	ER11	SGC060150	1.15
JT40-ER16-70	◐	JT40	28	70	LN16S	-	ER16	SGC100150	1.04
-100	●	JT40	28	100	LN16S	-	ER16	SGC100150	1.02
-160	○	JT40	28	160	LN16S	-	ER16	SGC100150	1.52
-200	○	JT40	28	200	LN16S	-	ER16	SGC100150	1.75
JT40-ER20-70	◐	JT40	34	70	LN20S	-	ER20	SGC120200	1.06
-100	◐	JT40	34	100	LN20S	-	ER20	SGC120200	1.38
-160	○	JT40	34	160	LN20S	-	ER20	SGC120200	1.65
-200	○	JT40	34	200	LN20S	-	ER20	SGC120200	1.65
JT40-ER25-70	●	JT40	42	70	LN25	WER25	ER25	SGC160200	1.14
-100	●	JT40	42	100	LN25	WER25	ER25	SGC160200	1.43
-160	◐	JT40	42	160	LN25	WER25	ER25	SGC160200	2.00
-200	○	JT40	42	200	LN25	WER25	ER25	SGC160200	2.35
JT40-ER32-70	◐	JT40	50	70	LN32	WER32	ER32	SGD220250	1.24
-100	●	JT40	50	100	LN32	WER32	ER32	SGD220250	1.67
-160	○	JT40	50	160	LN32	WER32	ER32	SGD220250	2.25
-200	○	JT40	50	200	LN32	WER32	ER32	SGD220250	3.10
JT40-ER40-70	◐	JT40	63	70	LN40	WER40	ER40	SGD280250	1.26
-100	○	JT40	63	100	LN40	WER40	ER40	SGD280250	1.60
-160	○	JT40	63	160	LN40	WER40	ER40	SGD280250	2.45

订货示例: JT40-ER11-70

● 常备库存 Unallocated stock ◐ 可备库存 Available stock ○ 订单生产 Order production

D 工具系统 Tool System

弹簧夹头刀柄-JT50
ER Collet Chucks

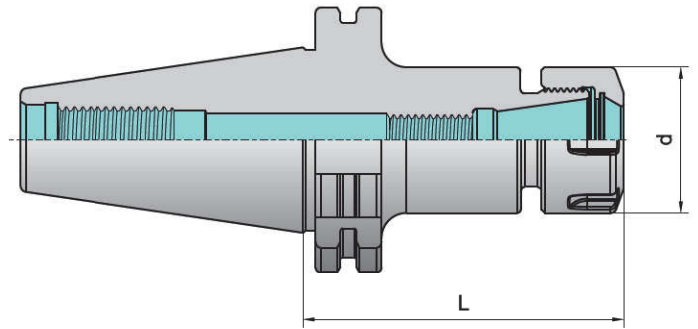
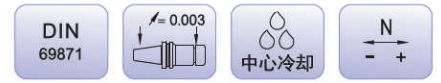

型号 Type	库存 Stock	锥柄型式 Taper type	尺寸(mm) Dimension		螺母 Nut	扳手 Wrench	卡簧 ERcollet	螺钉 Screw	重量 (kg)
			d	L					
JT50-ER11-70	○	JT50	19	70	LN11S		ER11	SGC060150	2.70
-100	○	JT50	19	100	LN11S	-	ER11	SGC060150	2.70
-160	○	JT50	19	160	LN11S	-	ER11	SGC060150	2.90
-200	○	JT50	19	200	LN11S	-	ER11	SGC060150	3.30
JT50-ER16-70	○	JT50	28	70	LN16S	-	ER16	SGC100150	2.75
-100	○	JT50	28	100	LN16S	-	ER16	SGC100150	3.00
-160	○	JT50	28	160	LN16S	-	ER16	SGC100150	3.30
-200	○	JT50	28	200	LN16S	-	ER16	SGC100150	3.55
JT50-ER20-70	○	JT50	34	70	LN20S	-	ER20	SGC120200	2.80
-100	●	JT50	34	100	LN20S	-	ER20	SGC120200	3.05
-160	●	JT50	34	160	LN20S	-	ER20	SGC120200	3.35
-200	●	JT50	34	200	LN20S	-	ER20	SGC120200	3.70
JT50-ER25-70	○	JT50	42	70	LN25	WER25	ER25	SGC160200	2.90
-100	●	JT50	42	100	LN25	WER25	ER25	SGC160200	3.20
-160	●	JT50	42	160	LN25	WER25	ER25	SGC160200	3.75
-200	●	JT50	42	200	LN25	WER25	ER25	SGC160200	4.10
JT50-ER32-70	●	JT50	50	70	LN32	WER32	ER32	SGD220250	2.90
-100	●	JT50	50	100	LN32	WER32	ER32	SGD220250	3.35
-160	●	JT50	50	160	LN32	WER32	ER32	SGD220250	4.15
-200	●	JT50	50	200	LN32	WER32	ER32	SGD220250	4.70
JT50-ER40-70	●	JT50	63	70	LN40	WER40	ER40	SGD280250	3.15
-100	●	JT50	63	100	LN40	WER40	ER40	SGD280250	3.80
-160	●	JT50	63	160	LN40	WER40	ER40	SGD280250	5.15
-200	●	JT50	63	200	LN40	WER40	ER40	SGD280250	6.05

订货示例: JT50-ER11-70

● 常备库存 Unallocated stock ● 可备库存 Available stock ○ 订单生产 Order production

D 工具系统 Tool System

液压夹头刀柄-BT30/BT40/BT50
Hydraulic Chucks

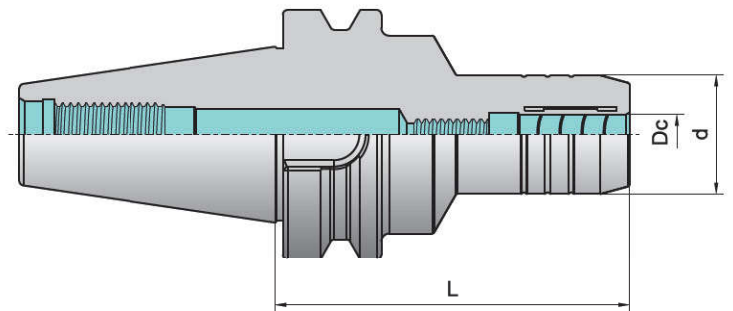
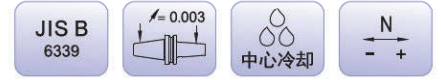

型号 Type	库存 Stock	锥柄型式 Taper type	尺寸(mm) Dimension			扳手 Wrench 	重量 (kg)
			Dc	d	L		
BT30-KHC06-70	○	BT30	6	28	70	TS4	
BT30-KHC08-70	○	BT30	8	30	70	TS4	
BT30-KHC10-75	○	BT30	10	32	75	TS4	
BT30-KHC12-75	○	BT30	12	34	75	TS4	
BT30-KHC16-90	○	BT30	16	38	90	TS4	
BT30-KHC20-90	○	BT30	20	43	90	TS4	
BT40-KHC06-90	●	BT40	6	28	90	TS4	
BT40-KHC08-90	●	BT40	8	30	90	TS4	
BT40-KHC10-90	○	BT40	10	32	90	TS4	
BT40-KHC12-90	●	BT40	12	34	90	TS4	
BT40-KHC16-90	●	BT40	16	38	90	TS4	
BT40-KHC20-90	●	BT40	20	43	90	TS4	
BT40-KHC25-100	○	BT40	25	57	100	TS5	
BT40-KHC32-105	●	BT40	32	63	105	TS5	
BT50-KHC12-90	○	BT50	12	34	90	TS4	
BT50-KHC20-90	○	BT50	20	43	90	TS4	
BT50-KHC32-115	●	BT50	32	63	115	TS5	

订货示例: BT30-KHC06-70

● 常备库存 Unallocated stock ● 可备库存 Available stock ○ 订单生产 Order production

工具系统
热胀工具系统 SHRINK FIT HOLDER
HSK工具系统 HSK TOOL SYSTEM
TMG21工具系统 TMG21 TOOL SYSTEM
7:24工具系统 7:24 TOOL SYSTEM
其它工具系统 SPECIAL TOOL SYSTEM
附件 ACCESSORIES

D 工具系统 Tool System

液压夹头刀柄-JT40/JT50
Hydraulic Chucks

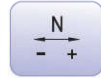
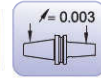

工具系统

SHRINK FIT HOLDER
热胀工具系统

HSK TOOL SYSTEM
HSK工具系统

TMG21 TOOL SYSTEM
TMG21工具系统

7:24 TOOL SYSTEM
7:24工具系统

SPECIAL TOOL SYSTEM
其它工具系统

ACCESSORIES
附件

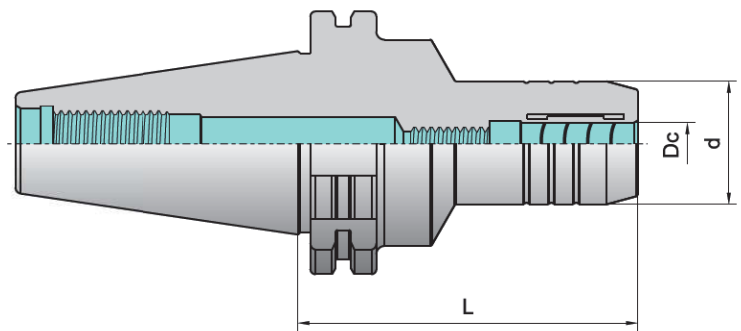

型号 Type	库存 Stock	锥柄型式 Taper type	尺寸(mm) Dimension			扳手 Wrench	重量 (kg)
			Dc	d	L		
JT40-KHC06-80	○	JT40	6	28	80	TS4	
JT40-KHC08-80	○	JT40	8	30	80	TS4	
JT40-KHC10-80	○	JT40	10	32	80	TS4	
JT40-KHC12-80	○	JT40	12	34	80	TS4	
JT40-KHC16-80	○	JT40	16	38	80	TS4	
JT40-KHC20-80	○	JT40	20	43	80	TS4	
JT40-KHC25-80	○	JT40	25	57	80	TS5	
JT40-KHC32-80	○	JT40	32	63	80	TS5	
JT50-KHC12-90	○	JT50	12	34	90	TS4	
JT50-KHC20-90	○	JT50	20	43	90	TS4	
JT50-KHC32-115	○	JT50	32	63	115	TS5	

订货示例: JT40-KHC06-80

● 常备库存
Unallocated stock

◐ 可备库存
Available stock

○ 订单生产
Order production

D 工具系统 Tool System

强力夹头刀柄-BT30/BT40/BT50
Power Chucks

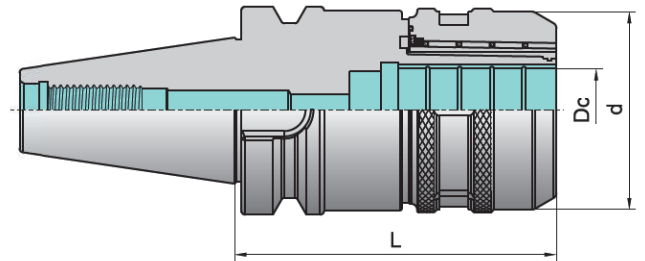
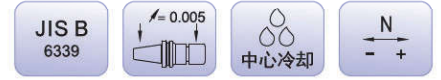

型号 Type	库存 Stock	锥柄型式 Tapertype	尺寸(mm) Dimension			扳手 Wrench	重量 (kg)
			Dc	d	L		
BT30-KMC20-75	○	BT30	20	53	75	WKMC20	
BT30-KMC25-80	●	BT30	25	62	80	WKMC25	
BT30-KMC32-100	○	BT30	32	70	100	WKMC32	
BT40-KMC20-80	●	BT40	20	53	80	WKMC20	
BT40-KMC25-80	●	BT40	25	62	80	WKMC25	
BT40-KMC32-105	●	BT40	32	70	105	WKMC32	
-135	○	BT40	32	70	135	WKMC32	
-165	●	BT40	32	70	165	WKMC32	
BT50-KMC20-105	○	BT50	20	53	105	WKMC20	
BT50-KMC25-105	●	BT50	25	62	105	WKMC25	
BT50-KMC32-105	●	BT50	32	70	105	WKMC32	
-135	●	BT50	32	70	135	WKMC32	
-165	●	BT50	32	70	165	WKMC32	
BT50-KMC42-115	●	BT50	42	92	115	WKMC42	
-135	●	BT50	42	92	135	WKMC42	
-165	●	BT50	42	92	165	WKMC42	

订货示例: BT30-KMC20-75

● 常备库存 Unallocated stock ● 可备库存 Available stock ○ 订单生产 Order production

工具系统
热胀工具系统 SHRINK FIT HOLDER
HSK工具系统 HSK TOOL SYSTEM
TMG21工具系统 TMG21 TOOL SYSTEM
7:24工具系统 7:24 TOOL SYSTEM
其它工具系统 SPECIAL TOOL SYSTEM
附件 ACCESSORIES

D 工具系统 Tool System

强力夹头刀柄-JT40/JT50
Power Chucks

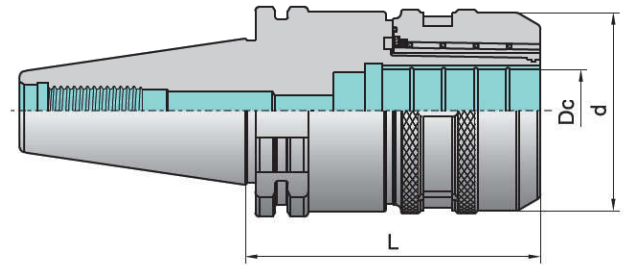
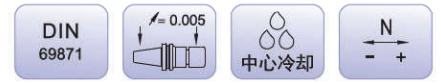

型号 Type	库存 Stock	锥柄型式 Tapertype	尺寸(mm) Dimension			扳手 Wrench	重量 (kg)
			Dc	d	L		
JT40-KMC20-90	○	JT40	20	53	90	WKMC20	
JT40-KMC25-90	○	JT40	25	62	90	WKMC25	
JT40-KMC32-105	●	JT40	32	70	105	WKMC32	
JT50-KMC20-105	○	JT50	20	53	105	WKMC20	
JT50-KMC25-105	○	JT50	25	62	105	WKMC25	
JT50-KMC32-105	●	JT50	32	70	105	WKMC32	
JT50-KMC42-115	○	JT50	42	92	115	WKMC42	

订货示例: JT40-KMC20-90

● 常备库存 Unallocated stock ◐ 可备库存 Available stock ○ 订单生产 Order production

D 工具系统 Tool System

强力夹头刀柄-M3/M4/M5/M6
Power Chucks

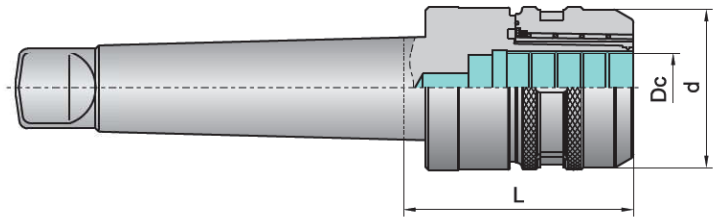
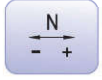
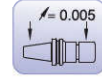

型号 Type	库存 Stock	锥柄型式 Tapertype	尺寸(mm) Dimension			扳手 Wrench	重量 (kg)
			Dc	d	L		
M3-KMC20-80	○	M3	20	53	80	WKMC20	
M4-KMC32-90	●	M4	32	70	90	WKMC32	
M5-KMC32-90	○	M5	32	70	90	WKMC32	
M6-KMC32-90	○	M6	32	70	90	WKMC32	
M6-KMC42-95	○	M6	42	92	95	WKMC42	

订货示例: M3-KMC20-80

常备库存 Unallocated stock
 可备库存 Available stock
 订单生产 Order production

工具系统
 热胀工具系统 SHRINK FIT HOLDER
 HSK工具系统 HSK TOOL SYSTEM
 TMG21工具系统 TMG21 TOOL SYSTEM
 7:24工具系统 7:24 TOOL SYSTEM
 其它工具系统 SPECIAL TOOL SYSTEM
 附件 ACCESSORIES

D 工具系统 Tool System

侧固式刀柄-BT40/BT50短型
Side-Locked Holders-STUB

JIS B
6339

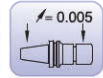

型式 I

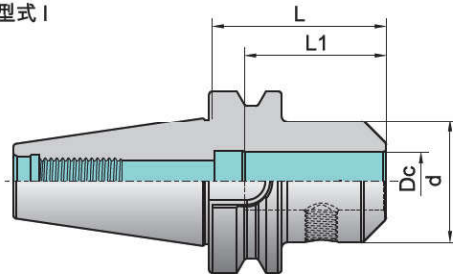

型式 II

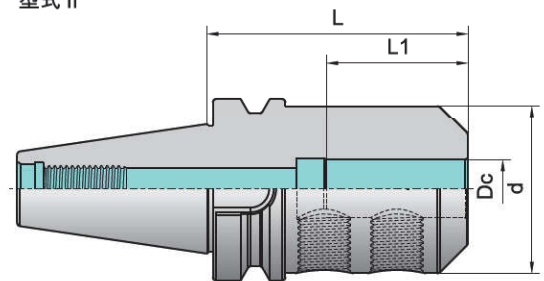

型号 Type	库存 Stock	锥柄型式 Tapertype	尺寸(mm) Dimension				螺钉 Screw	扳手 Wrench	螺钉 Screw	扳手 Wrench	型式 Model	重量 (kg)
			Dc	d	L1	L						
BT40-XP16-35	○	BT40	16	48	47	35	SXP16A	S6	-	-	I	1.00
BT40-XP20-35	◐	BT40	20	52	49	35	SXP16A	S6	-	-	I	0.97
BT40-XP25-60	●	BT40	25	65	54	60	SXP25	S8	SXP16A	S6	II	1.42
BT40-XP32-65	●	BT40	32	72	58	65	SXP32	S10	SXP10A	S5	II	1.33
BT50-XP16-45	○	BT50	16	48	47	45	SXP16	S6	-	-	I	3.56
BT50-XP20-45	○	BT50	20	52	49	45	SXP20	S8	-	-	I	3.54
BT50-XP25-72	●	BT50	25	65	54	72	SXP25	S8	-	-	II	4.11
BT50-XP32-75	●	BT50	32	72	58	75	SXP32	S10	-	-	II	4.21

订货示例: BT40-XP16-35

● 常备库存
Unallocated stock

◐ 可备库存
Available stock

○ 订单生产
Order production

D 工具系统 Tool System

侧固式刀柄-BT40 Side-Locked Holders

JIS B
6339

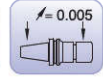

型式 I

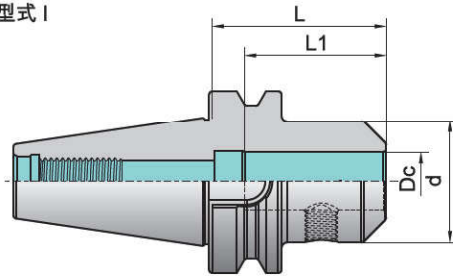

型式 II

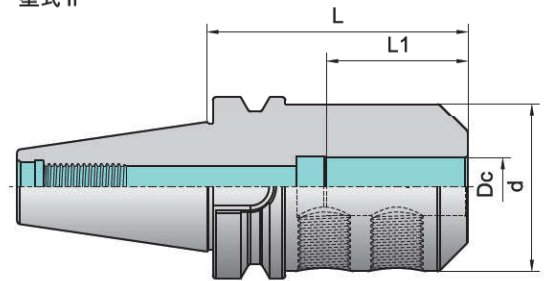

型号 Type	库存 Stock	锥柄型式 Tapertype	尺寸(mm) Dimension				螺钉 Screw	扳手 Wrench	型式 Model	重量 (kg)
			Dc	d	L1	L				
BT40-XP12-63	●	BT40	12	42	44	63	SXP12	S6	I	1.28
-100	○	BT40	12	42	44	100	SXP12	S6	I	1.35
-160	○	BT40	12	42	44	160	SXP12	S6	I	1.64
BT40-XP16-63	●	BT40	16	48	47	63	SXP16	S6	I	1.38
-100	●	BT40	16	48	47	100	SXP16	S6	I	1.83
-160	○	BT40	16	48	47	160	SXP16	S6	I	2.63
BT40-XP20-63	●	BT40	20	52	49	63	SXP20	S8	I	1.96
-100	●	BT40	20	52	49	100	SXP20	S8	I	2.21
-160	○	BT40	20	52	49	160	SXP20	S8	I	2.89
BT40-XP25-90	●	BT40	25	65	54	90	SXP25	S8	II	2.62
-160	●	BT40	25	65	54	160	SXP25	S8	II	3.74
BT40-XP32-100	●	BT40	32	72	58	100	SXP32	S10	II	3.80
-160	●	BT40	32	72	58	160	SXP32	S10	II	3.96

订货示例: BT40-XP12-63

● 常备库存
Unallocated stock

● 可备库存
Available stock

○ 订单生产
Order production

工具系统
热胀工具系统
SHRINK FIT HOLDER
HSK工具系统
HSK TOOL SYSTEM
TMG21工具系统
TMG21 TOOL SYSTEM
7:24工具系统
7:24 TOOL SYSTEM
其它工具系统
SPECIAL TOOL SYSTEM
附件
ACCESSORIES

D 工具系统 Tool System

侧固式刀柄-BT50 Side-Locked Holders

JIS B
6339

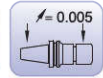

型式 I

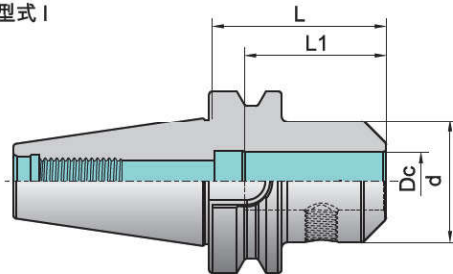

型式 II

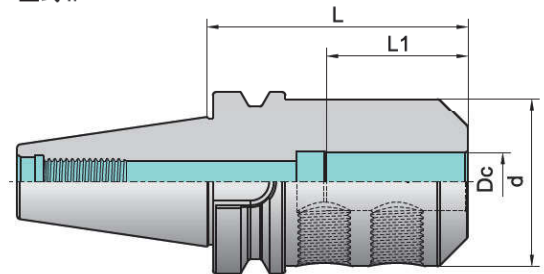

型号 Type	库存 Stock	锥柄型式 Tapertype	尺寸(mm) Dimension				螺钉 Screw	扳手 Wrench	型式 Model	重量 (kg)
			Dc	d	L1	L				
BT50-XP16-80	●	BT50	16	48	47	80	SXP16	S6	I	3.61
-100	◐	BT50	16	48	47	100	SXP16	S6	I	3.83
-160	◑	BT50	16	48	47	160	SXP16	S6	I	4.05
BT50-XP20-80	●	BT50	20	52	49	80	SXP20	S8	I	3.75
-100	●	BT50	20	52	49	100	SXP20	S8	I	4.04
-160	●	BT50	20	52	49	160	SXP20	S8	I	5.20
BT50-XP25-100	●	BT50	25	65	54	100	SXP25	S8	II	4.80
-160	●	BT50	25	65	54	160	SXP25	S8	II	6.21
BT50-XP32-105	●	BT50	32	72	58	105	SXP32	S10	II	5.13
-160	●	BT50	32	72	58	160	SXP32	S10	II	6.74
BT50-XP40-120	●	BT50	40	80	68	120	SXP40	S10	II	6.14
-160	●	BT50	40	80	68	160	SXP40	S10	II	7.80

订货示例: BT50-XP16-80

● 常备库存
Unallocated stock

◐ 可备库存
Available stock

○ 订单生产
Order production

D 工具系统 Tool System

侧固式刀柄-JT40短型
Side-Locked Holders-STUB

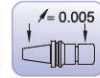

型式 I

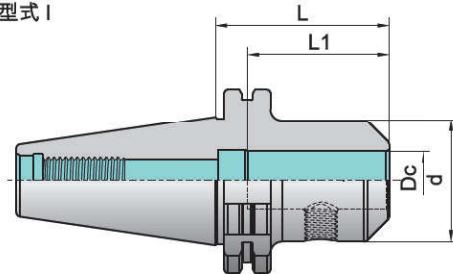

型式 II

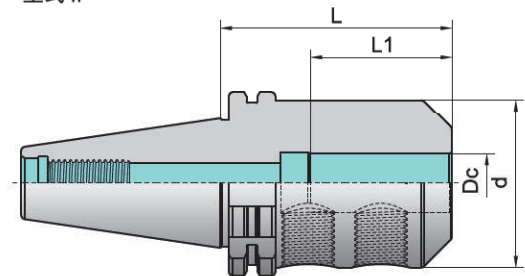

型号 Type	库存 Stock	锥柄型式 Tapertype	尺寸(mm) Dimension				螺钉 Screw	扳手 Wrench	型式 Model	重量 (kg)
			Dc	d	L1	L				
JT40-XP12-50	○	JT40	12	42	44	50	SXP12	S6	I	1.07
-100	●	JT40	12	42	44	100	SXP12	S6	I	1.56
JT40-XP16-63	○	JT40	16	48	47	63	SXP16	S6	I	1.29
-100	○	JT40	16	48	47	100	SXP16	S6	I	1.78
JT40-XP20-63	○	JT40	20	52	49	63	SXP20	S8	I	1.30
-100	○	JT40	20	52	49	100	SXP20	S8	I	1.82
JT40-XP25-100	◐	JT40	25	65	54	100	SXP25	S8	II	2.36
JT40-XP32-100	●	JT40	32	72	58	100	SXP32	S10	II	2.53

订货示例: JT40-XP12-50

● 常备库存
Unallocated stock

◐ 可备库存
Available stock

○ 订单生产
Order production

D 工具系统 Tool System

侧固式刀柄-JT50 Side-Locked Holders

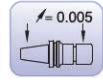

型式 I

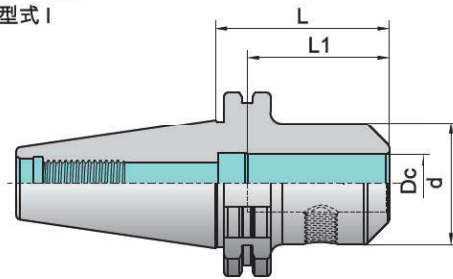

型式 II

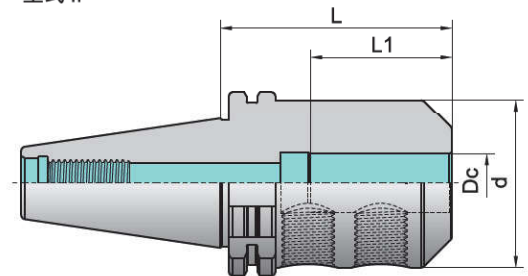

型号 Type	库存 Stock	锥柄型式 Tapertype	尺寸(mm) Dimension				螺钉 Screw	扳手 Wrench	型式 Model	重量 (kg)
			Dc	d	L1	L				
JT50-XP16-63	○	JT50	16	48	47	63	SXP16	S6	I	3.05
-100	●	JT50	16	48	47	100	SXP16	S6	I	3.58
-160	○	JT50	16	48	47	160	SXP16	S6	I	4.48
JT50-XP20-63	○	JT50	20	52	49	63	SXP20	S8	I	3.10
-100	●	JT50	20	52	49	100	SXP20	S8	I	3.66
-160	○	JT50	20	52	49	160	SXP20	S8	I	4.50
JT50-XP25-80	●	JT50	25	65	54	80	SXP25	S8	II	3.78
-160	●	JT50	25	65	54	160	SXP25	S8	II	5.64
JT50-XP32-100	●	JT50	32	72	58	100	SXP32	S10	II	4.49
-160	●	JT50	32	72	58	160	SXP32	S10	II	6.35
JT50-XP40-100	●	JT50	40	80	68	100	SXP40	S10	II	5.06
-160	●	JT50	40	80	68	160	SXP40	S10	II	7.19

订货示例: JT50-XP16-63

● 常备库存
Unallocated stock

● 可备库存
Available stock

○ 订单生产
Order production

D 工具系统 Tool System

2° 侧固式刀柄-BT40/BT50
2° Side Locked Holders

JIS B
6339

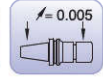

型式 I

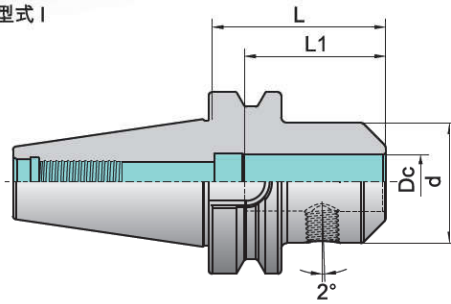

型式 II

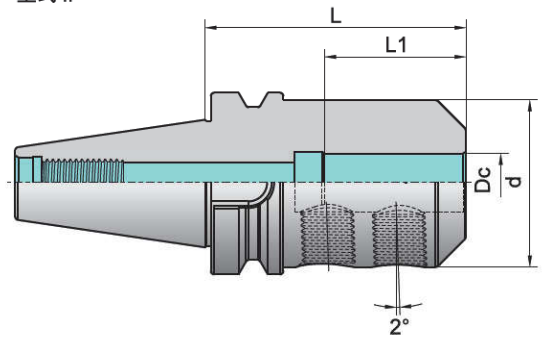

型号 Type	库存 Stock	锥柄型式 Taper type	尺寸(mm) Dimension				螺钉 Screw	扳手 Wrench	螺钉 Screw	型式 Model	重量 (kg)
			Dc	d	L1	L					
BT40-XPD12-63	○	BT40	12	42	44	63	SXP12	S6	SGC100150	I	1.25
BT40-XPD16-63	○	BT40	16	48	47	63	SXP16	S6	SGC120200	I	1.37
BT40-XPD20-63	●	BT40	20	52	49	63	SXP20	S8	SGC160200	I	1.38
BT40-XPD25-90	●	BT40	25	65	54	90	SXP25	S8	SGD220250	II	2.18
BT40-XPD32-100	●	BT40	32	72	58	100	SXP32	S10	SGD280250	II	2.66
BT50-XPD12-80	○	BT50	12	42	44	80	SXP12	S6	SGC100150	I	3.90
BT50-XPD16-80	○	BT50	16	48	47	80	SXP16	S6	SGC120200	I	4.30
BT50-XPD20-80	●	BT50	20	52	49	80	SXP20	S8	SGC160200	I	4.06
BT50-XPD25-100	●	BT50	25	65	54	100	SXP25	S8	SGD220250	II	4.90
BT50-XPD32-105	●	BT50	32	72	58	105	SXP32	S10	SGD280250	II	5.19
BT50-XPD40-120	●	BT50	40	80	68	120	SXP40	S10	SGD280250	II	6.19

订货示例: BT40-XPD12-63

● 常备库存
Unallocated stock

◐ 可备库存
Available stock

○ 订单生产
Order production

D 工具系统 Tool System

2° 侧固式刀柄-JT40/JT50
2° Side Locked Holders

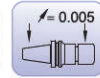

型式 I

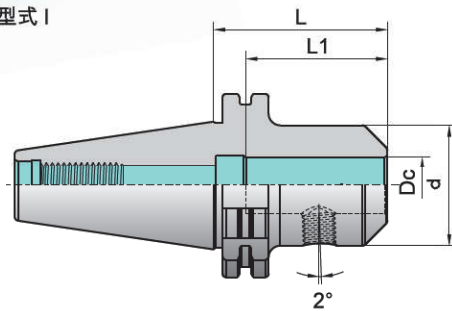

型式 II

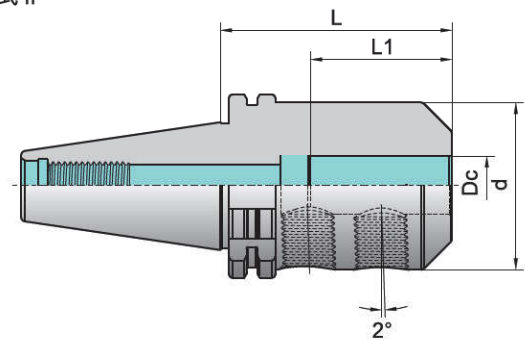

型号 Type	库存 Stock	锥柄型式 Taper type	尺寸(mm) Dimension				螺钉 Screw	扳手 Wrench	螺钉 Screw	型式 Model	重量 (kg)
			Dc	d	L1	L					
JT40-XP12-50	○	JT40	12	42	44	50	SXP12	S6	SGC100150	I	1.05
JT40-XP16-63	○	JT40	16	48	47	63	SXP16	S6	SGC120200	I	1.31
JT40-XP20-63	○	JT40	20	52	49	63	SXP20	S8	SGC160200	I	1.30
JT40-XP25-100	○	JT40	25	65	54	100	SXP25	S8	SGD220250	II	2.40
JT40-XP32-100	●	JT40	32	72	58	100	SXP32	S10	SGD280250	II	2.55
JT50-XP16-63	○	JT50	16	48	47	63	SXP16	S6	SGC120200	I	3.10
JT50-XP20-63	○	JT50	20	52	49	63	SXP20	S8	SGC160200	I	3.15
JT50-XP25-80	○	JT50	25	65	54	80	SXP25	S8	SGD220250	II	3.85
JT50-XP32-100	●	JT50	32	72	58	100	SXP32	S10	SGD280250	II	4.55
JT50-XP40-100	●	JT50	40	80	68	100	SXP40	S10	SGD280250	II	5.00

订货示例: JT40-XP12-50

● 常备库存
Unallocated stock

◐ 可备库存
Available stock

○ 订单生产
Order production

D 工具系统 Tool System

面铣刀刀柄-BT30/BT40 Shell Mill Holder

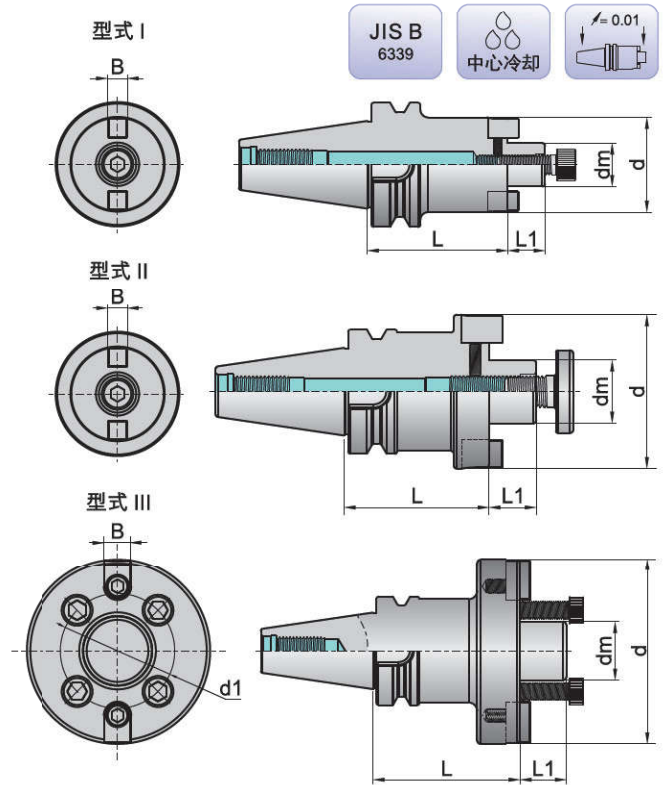
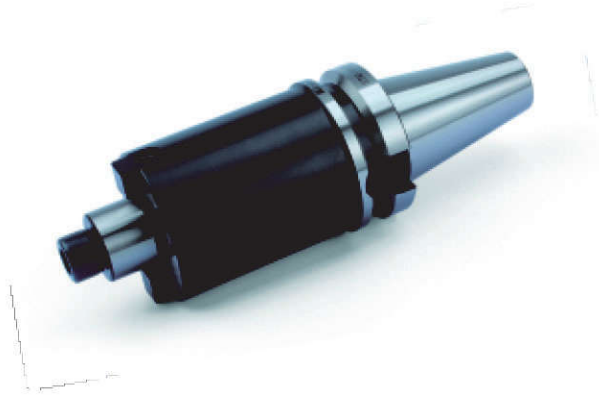

型号 Type	库存 Stock	锥柄型式 Taper type	尺寸(mm) Dimension						螺钉 Screw	扳手 Wrench	键 Key	型式 Model	重量 (kg)
			dm	d	d1	B	L1	L					
BT30-XMA16-30	○	BT30	16	38	-	8	17	30	SCC080300	S6	KXMA16	I	0.48
-100	○	BT30	16	38	-	8	17	100	SCC080300	S6	KXMA16	I	1.07
BT30-XMA22-45	●	BT30	22	48	-	10	19	45	SCC100300	S8	KXMA22	I	0.08
-100	○	BT30	22	48	-	10	19	100	SCC100300	S8	KXMA22	I	1.35
BT30-XMA27-45	◐	BT30	27	60	-	12	21	45	SCC120350	S10	KXMA27	I	0.94
-100	○	BT30	27	60	-	12	21	100	SCC120350	S10	KXMA27	I	1.55
BT40-XMA16-35	●	BT40	16	38	-	8	17	35	SCC080300	S6	KXMA16	I	1.11
-100	●	BT40	16	38	-	8	17	100	SCC080300	S6	KXMA16	I	1.62
-160	○	BT40	16	38	-	8	17	160	SCC080300	S6	KXMA16	I	2.10
BT40-XMA22-40	●	BT40	22	48	-	10	19	40	SCC100300	S8	KXMA22	I	1.20
-100	●	BT40	22	48	-	10	19	100	SCC100300	S8	KXMA22	I	2.02
-160	●	BT40	22	48	-	10	19	160	SCC100300	S8	KXMA22	I	2.80
BT40-XMA27-40	●	BT40	27	60	-	12	21	40	SCC120350	S10	KXMA27	I	1.34
-100	●	BT40	27	60	-	12	21	100	SCC120350	S10	KXMA27	I	2.60
-160	○	BT40	27	60	-	12	21	160	SCC120350	S10	KXMA27	I	3.88
BT40-XMB32-50	●	BT40	32	78	-	14	24	50	SXMB32	S12	KXMB32	II	1.95
-100	●	BT40	32	78	-	14	24	100	SXMB32	S12	KXMB32	II	3.01
-160	○	BT40	32	78	-	14	24	160	SXMB32	S12	KXMB32	II	4.25
BT40-XMB40-60	●	BT40	40	89	-	16	27	60	SXMB40	S14	KXMB40	II	2.56
-100	●	BT40	40	89	-	16	27	100	SXMB40	S14	KXMB40	II	3.42
BT40-XMC40-60	●	BT40	40	108	66.7	16	27	60	SCC120350	S10	KXMC40	III	3.01

订货示例: BT30-XMA16-30

● 常备库存 Unallocated stock ◐ 可备库存 Available stock ○ 订单生产 Order production

D 工具系统 Tool System

面铣刀刀柄-BT50
Shell Mill Holder

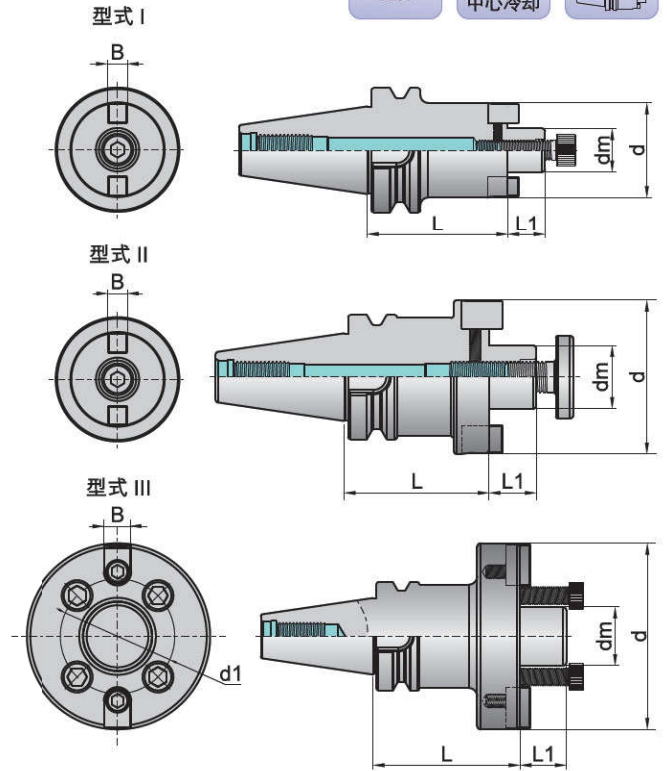

型号 Type	库存 Stock	锥柄型式 Taper type	尺寸(mm) Dimension						螺钉 Screw	扳手 Wrench	键 Key	型式 Model	重量 (kg)
			dm	d	d1	B	L1	L					
BT50-XMA16-55	●	BT50	16	38	-	8	17	55	SCC080300	S6	KXMA16	I	3.65
-100	●	BT50	16	38	-	8	17	100	SCC080300	S6	KXMA16	I	4.06
-160	●	BT50	16	38	-	8	17	160	SCC080300	S6	KXMA16	I	4.62
BT50-XMA22-55	●	BT50	22	48	-	10	19	55	SCC100300	S8	KXMA22	I	3.83
-100	●	BT50	22	48	-	10	19	100	SCC100300	S8	KXMA22	I	4.45
-160	●	BT50	22	48	-	10	19	160	SCC100300	S8	KXMA22	I	5.36
BT50-XMA27-55	●	BT50	27	60	-	12	21	55	SCC120350	S10	KXMA27	I	4.10
-100	●	BT50	27	60	-	12	21	100	SCC120350	S10	KXMA27	I	5.15
-160	●	BT50	27	60	-	12	21	160	SCC120350	S10	KXMA27	I	6.20
BT50-XMB32-55	●	BT50	32	78	-	14	24	55	SXMB32	S12	KXMB32	II	4.36
-100	●	BT50	32	78	-	14	24	100	SXMB32	S12	KXMB32	II	5.96
-160	●	BT50	32	78	-	14	24	160	SXMB32	S12	KXMB32	II	7.98
BT50-XMB40-55	●	BT50	40	89	-	16	27	55	SXMB40	S14	KXMB40	II	4.71
-100	●	BT50	40	89	-	16	27	100	SXMB40	S14	KXMB40	II	5.65
-160	●	BT50	40	89	-	16	27	160	SXMB40	S14	KXMB40	II	9.59
BT50-XMC40-55	●	BT50	40	108	66.7	16	27	55	SCC120350	S10	KXMC40	III	4.75
BT50-XMC60-70	●	BT50	60	129	101.6	25.4	38	70	SCC160450	S14	KXMC60	III	7.74

订货示例: BT50-XMA16-55

● 常备库存 Unallocated stock ● 可备库存 Available stock ○ 订单生产 Order production

D 工具系统 Tool System

面铣刀刀柄-BT40/BT50加长型
Shell Mill Holder

JIS B
6339

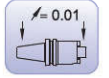

型式 I

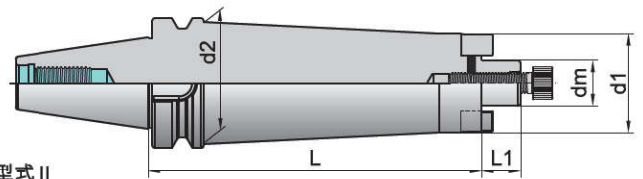

型式 II

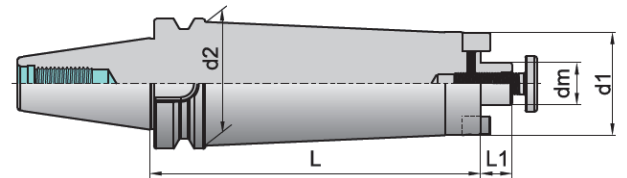
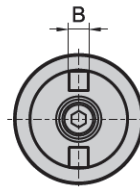

型号 Type	库存 Stock	锥柄型式 Taper type	尺寸(mm) Dimension						螺钉 Screw	扳手 Wrench	键 Key	型式 Model	重量 (kg)
			dm	d1	d2	B	L1	L					
BT40-XMA22-200BG	●	BT40	22	48	61	10	19	200	SCC100300	S8	KXMA22	I	
-250BG	●	BT40	22	48	61	10	19	250	SCC100300	S8	KXMA22	I	
-300BG	○	BT40	22	48	61	10	19	300	SCC100300	S8	KXMA22	I	
-350BG	○	BT40	22	48	61	10	19	350	SCC100300	S8	KXMA22	I	
-400BG	○	BT40	22	48	61	10	19	400	SCC100300	S8	KXMA22	I	
BT50-XMA22-200BG	●	BT50	22	48	61	10	19	200	SCC100300	S8	KXMA22	I	
-250BG	●	BT50	22	48	61	10	19	250	SCC100300	S8	KXMA22	I	
-300BG	●	BT50	22	48	61	10	19	300	SCC100300	S8	KXMA22	I	
-350BG	○	BT50	22	48	61	10	19	350	SCC100300	S8	KXMA22	I	
-400BG	○	BT50	22	48	61	10	19	400	SCC100300	S8	KXMA22	I	
-450BG	○	BT50	22	48	61	10	19	450	SCC100300	S8	KXMA22	I	
-500BG	○	BT50	22	48	61	10	19	500	SCC100300	S8	KXMA22	I	
-550BG	○	BT50	22	48	61	10	19	550	SCC100300	S8	KXMA22	I	
-600BG	○	BT50	22	48	61	10	19	600	SCC100300	S8	KXMA22	I	

订货示例: BT40-XMA22-200BG

● 常备库存
Unallocated stock

● 可备库存
Available stock

○ 订单生产
Order production

工具系统

热胀工具系统
SHRINK FIT HOLDER

HSK工具系统
HSK TOOL SYSTEM

TMG21工具系统
TMG21 TOOL SYSTEM

7:24工具系统
7/24 TOOL SYSTEM

其它工具系统
SPECIAL TOOL SYSTEM

附件
ACCESSORIES

D 工具系统 Tool System

面铣刀刀柄-BT50加长型
Shell Mill Holder

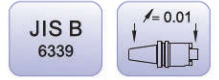

型式 I

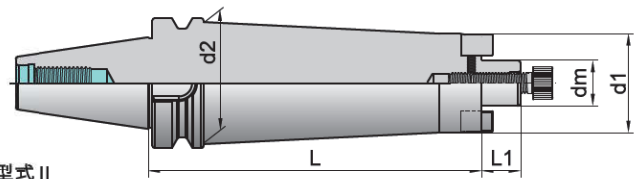

型式 II

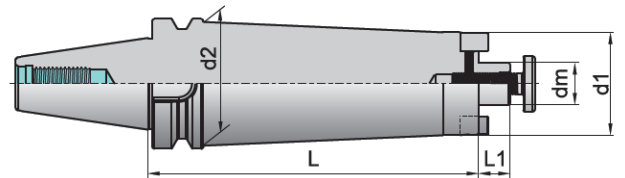
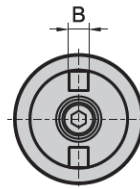

型号 Type	库存 Stock	锥柄型式 Taper type	尺寸(mm) Dimension						螺钉 Screw	扳手 Wrench	键 Key	型式 Model	重量 (kg)
			dm	d1	d2	B	L1	L					
BT50-XMA27-200BG	●	BT50	27	60	78	12	21	200	SCC120350	S10	KXMA27	I	
-250BG	●	BT50	27	60	78	12	21	250	SCC120350	S10	KXMA27	I	
-300BG	●	BT50	27	60	78	12	21	300	SCC120350	S10	KXMA27	I	
-350BG	○	BT50	27	60	78	12	21	350	SCC120350	S10	KXMA27	I	
-400BG	●	BT50	27	60	78	12	21	400	SCC120350	S10	KXMA27	I	
-450BG	○	BT50	27	60	78	12	21	450	SCC120350	S10	KXMA27	I	
-500BG	○	BT50	27	60	78	12	21	500	SCC120350	S10	KXMA27	I	
-550BG	○	BT50	27	60	78	12	21	550	SCC120350	S10	KXMA27	I	
-600BG	○	BT50	27	60	78	12	21	600	SCC120350	S10	KXMA27	I	
BT50-XMB32-200BG	●	BT50	32	78	98	14	24	200	SXMB32	S12	KXMB32	II	
-250BG	●	BT50	32	78	98	14	24	250	SXMB32	S12	KXMB32	II	
-300BG	●	BT50	32	78	98	14	24	300	SXMB32	S12	KXMB32	II	
-350BG	○	BT50	32	78	98	14	24	350	SXMB32	S12	KXMB32	II	
-400BG	○	BT50	32	78	98	14	24	400	SXMB32	S12	KXMB32	II	

订货示例: BT50-XMA27-200BG

● 常备库存 Unallocated stock ● 可备库存 Available stock ○ 订单生产 Order production

D 工具系统 Tool System

面铣刀刀柄-JT40
Shell Mill Holder

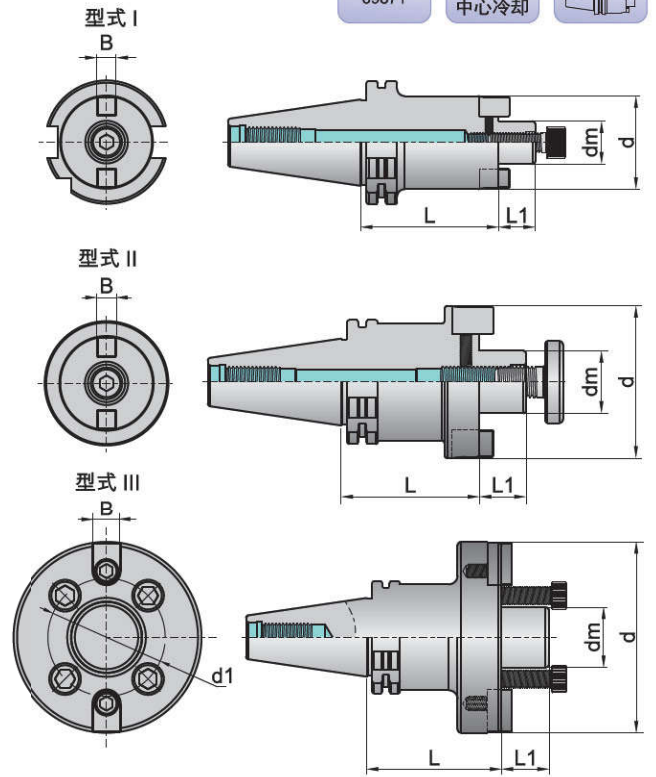
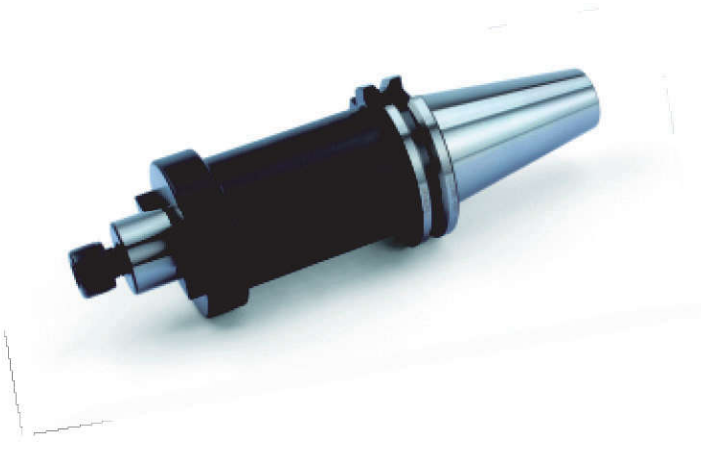

型号 Type	库存 Stock	锥柄型式 Taper type	尺寸(mm) Dimension						螺钉 Screw	扳手 Wrench	键 Key	型式 Model	重量 (kg)
			dm	d	d1	B	L1	L					
JT40-XMA16-35	●	JT40	16	38	-	8	17	35	SCC080300	S6	KXMA16	I	0.93
-100	○	JT40	16	38	-	8	17	100	SCC080300	S6	KXMA16	I	1.30
-160	○	JT40	16	38	-	8	17	160	SCC080300	S6	KXMA16	I	1.99
JT40-XMA22-35	○	JT40	22	48	-	10	19	35	SCC100300	S8	KXMA22	I	1.08
-100	●	JT40	22	48	-	10	19	100	SCC100300	S8	KXMA22	I	1.60
-160	○	JT40	22	48	-	10	19	160	SCC100300	S8	KXMA22	I	2.74
JT40-XMA27-50	○	JT40	27	60	-	12	21	50	SCC120350	S10	KXMA27	I	1.45
-100	○	JT40	27	60	-	12	21	100	SCC120350	S10	KXMA27	I	2.21
-160	○	JT40	27	60	-	12	21	160	SCC120350	S10	KXMA27	I	3.05
JT40-XMB32-55	●	JT40	32	78	-	14	24	55	SXMB32	S12	KXMB32	II	1.80
-100	○	JT40	32	78	-	14	24	100	SXMB32	S12	KXMB32	II	2.58
-160	○	JT40	32	78	-	14	24	160	SXMB32	S12	KXMB32	II	3.50
JT40-XMB40-55	○	JT40	40	89	-	16	27	55	SXMB40	S14	KXMB40	II	2.37
-100	○	JT40	40	89	-	16	27	100	SXMB40	S14	KXMB40	II	2.99
JT40-XMC40-55	○	JT40	40	108	66.7	16	27	55	SCC120350	S10	KXMC40	III	2.55

订货示例: JT40-XMA16-35

● 常备库存 Unallocated stock ● 可备库存 Available stock ○ 订单生产 Order production

工具系统
热胀工具系统 SHRINK FIT HOLDER
HSK工具系统 HSK TOOL SYSTEM
TMG21工具系统 TMG21 TOOL SYSTEM
7:24工具系统 7:24 TOOL SYSTEM
其它工具系统 SPECIAL TOOL SYSTEM
附件 ACCESSORIES

D 工具系统 Tool System

面铣刀刀柄-JT50
Shell Mill Holder

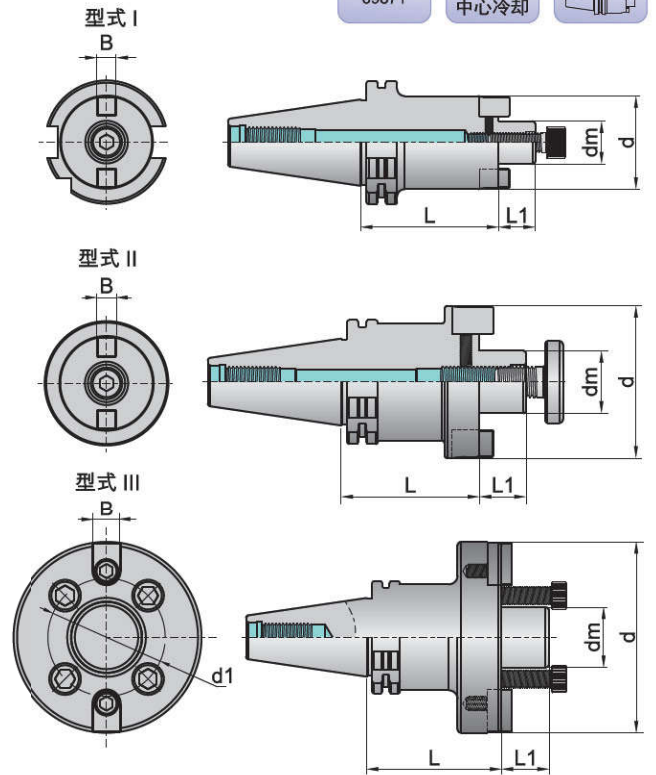

型号 Type	库存 Stock	锥柄型式 Taper type	尺寸(mm) Dimension						螺钉 Screw	扳手 Wrench	键 Key	型式 Model	重量 (kg)
			dm	d	d1	B	L1	L					
JT50-XMA16-35	○	JT50	16	38	-	8	17	35	SCC080300	S6	KXMA16	I	2.80
-100	○	JT50	16	38	-	8	17	100	SCC080300	S6	KXMA16	I	3.30
-160	○	JT50	16	38	-	8	17	160	SCC080300	S6	KXMA16	I	3.80
JT50-XMA22-35	●	JT50	22	48	-	10	19	35	SCC100300	S8	KXMA22	I	2.90
-100	●	JT50	22	48	-	10	19	100	SCC100300	S8	KXMA22	I	3.75
-160	●	JT50	22	48	-	10	19	160	SCC100300	S8	KXMA22	I	4.60
JT50-XMA27-35	○	JT50	27	60	-	12	21	35	SCC120350	S10	KXMA27	I	2.98
-100	○	JT50	27	60	-	12	21	100	SCC120350	S10	KXMA27	I	4.44
-160	○	JT50	27	60	-	12	21	160	SCC120350	S10	KXMA27	I	5.68
JT50-XMB32-35	○	JT50	32	78	-	14	24	35	SXMB32	S12	KXMB32	II	3.34
-100	○	JT50	32	78	-	14	24	100	SXMB32	S12	KXMB32	II	5.64
-160	○	JT50	32	78	-	14	24	160	SXMB32	S12	KXMB32	II	7.75
JT50-XMB40-55	○	JT50	40	89	-	16	27	55	SXMB40	S14	KXMB40	II	4.24
-100	○	JT50	40	89	-	16	27	100	SXMB40	S14	KXMB40	II	6.12
-160	○	JT50	40	89	-	16	27	160	SXMB40	S14	KXMB40	II	8.60
JT50-XMC40-55	○	JT50	40	108	66.7	16	27	55	SCC120350	S10	KXMC40	III	4.72
JT50-XMC60-70	○	JT50	60	129	101.6	25.4	38	70	SCC160450	S14	KXMC60	III	7.36

订货示例: JT50-XMA16-35

● 常备库存 Unallocated stock ○ 可备库存 Available stock ○ 订单生产 Order production

D 工具系统 Tool System

面铣刀刀柄-JT40/JT50加长型
Shell Mill Holder

DIN
69871

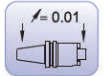

型式 I

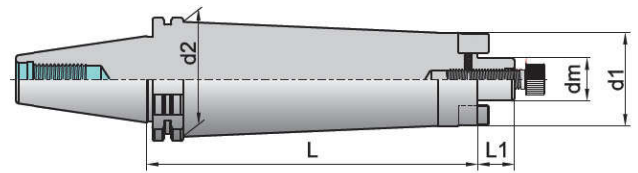

型式 II

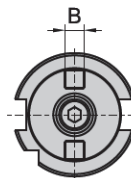
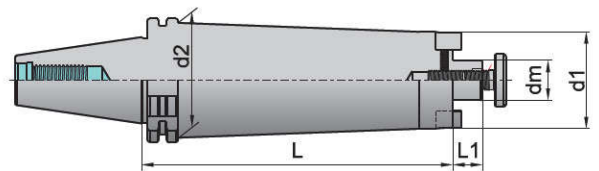

型号 Type	库存 Stock	锥柄型式 Taper type	尺寸(mm) Dimension						螺钉 Screw	扳手 Wrench	键 Key	型式 Model	重量 (kg)
			dm	d1	d2	B	L1	L					
JT40-XMA22-200BG	○	JT40	22	48	50	10	19	200	SCC100300	S8	KXMA22	I	
-250BG	○	JT40	22	48	50	10	19	250	SCC100300	S8	KXMA22	I	
-300BG	○	JT40	22	48	50	10	19	300	SCC100300	S8	KXMA22	I	
-350BG	○	JT40	22	48	50	10	19	350	SCC100300	S8	KXMA22	I	
-400BG	○	JT40	22	48	50	10	19	400	SCC100300	S8	KXMA22	I	
JT50-XMA22-200BG	○	JT50	22	48	61	10	19	200	SCC100300	S8	KXMA22	I	
-250BG	○	JT50	22	48	61	10	19	250	SCC100300	S8	KXMA22	I	
-300BG	○	JT50	22	48	61	10	19	300	SCC100300	S8	KXMA22	I	
-350BG	○	JT50	22	48	61	10	19	350	SCC100300	S8	KXMA22	I	
-400BG	○	JT50	22	48	61	10	19	400	SCC100300	S8	KXMA22	I	
-450BG	○	JT50	22	48	61	10	19	450	SCC100300	S8	KXMA22	I	
-500BG	○	JT50	22	48	61	10	19	500	SCC100300	S8	KXMA22	I	
-550BG	○	JT50	22	48	61	10	19	550	SCC100300	S8	KXMA22	I	
-600BG	○	JT50	22	48	61	10	19	600	SCC100300	S8	KXMA22	I	

订货示例: JT40-XMA22-200BG

● 常备库存 Unallocated stock ● 可备库存 Available stock ○ 订单生产 Order production

工具系统
热胀工具系统 SHRINK FIT HOLDER
HSK工具系统 HSK TOOL SYSTEM
TMG21工具系统 TMG21 TOOL SYSTEM
7:24工具系统 7:24 TOOL SYSTEM
其它工具系统 SPECIAL TOOL SYSTEM
附件 ACCESSORIES

D 工具系统 Tool System

面铣刀刀柄-JT50加长型
Shell Mill Holder

DIN
69871

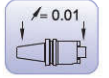

型式 I

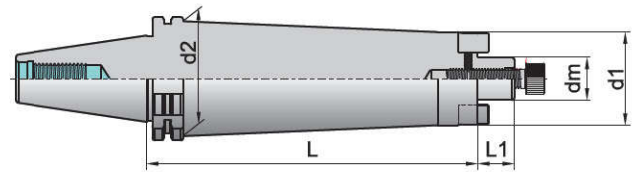

型式 II

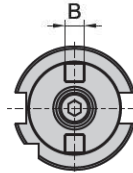
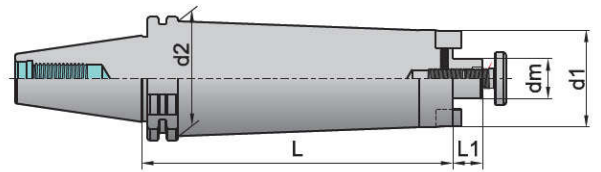

型号 Type	库存 Stock	锥柄型式 Taper type	尺寸(mm) Dimension						螺钉 Screw	扳手 Wrench	键 Key	型式 Model	重量 (kg)
			dm	d1	d2	B	L1	L					
JT50-XMA27-200BG	●	JT50	27	60	78	12	21	200	SCC120350	S10	KXMA27	I	
-250BG	○	JT50	27	60	78	12	21	250	SCC120350	S10	KXMA27	I	
-300BG	○	JT50	27	60	78	12	21	300	SCC120350	S10	KXMA27	I	
-350BG	○	JT50	27	60	78	12	21	350	SCC120350	S10	KXMA27	I	
-400BG	○	JT50	27	60	78	12	21	400	SCC120350	S10	KXMA27	I	
-450BG	○	JT50	27	60	78	12	21	450	SCC120350	S10	KXMA27	I	
-500BG	○	JT50	27	60	78	12	21	500	SCC120350	S10	KXMA27	I	
-550BG	○	JT50	27	60	78	12	21	550	SCC120350	S10	KXMA27	I	
-600BG	○	JT50	27	60	78	12	21	600	SCC120350	S10	KXMA27	I	
JT50-XMB32-200BG	○	JT50	32	78	80	14	24	200	SXMB32	S12	KXMB32	II	
-250BG	○	JT50	32	78	80	14	24	250	SXMB32	S12	KXMB32	II	
-300BG	○	JT50	32	78	80	14	24	300	SXMB32	S12	KXMB32	II	
-350BG	○	JT50	32	78	80	14	24	350	SXMB32	S12	KXMB32	II	
-400BG	○	JT50	32	78	80	14	24	400	SXMB32	S12	KXMB32	II	

订货示例: JT50-XMA27-200BG

● 常备库存
Unallocated stock

◐ 可备库存
Available stock

○ 订单生产
Order production

D 工具系统 Tool System

套式立铣刀及三面刃铣刀刀柄-BT40
Shell Mill&Disc Mill Holder

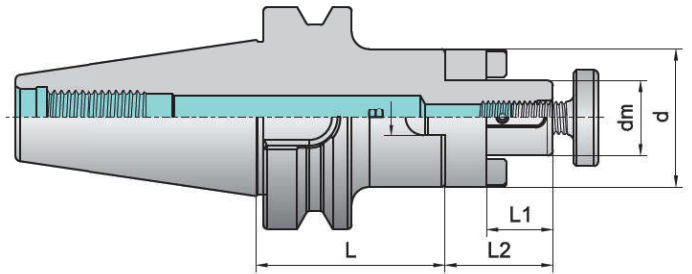
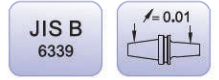

型号 Type	库存 Stock	锥柄型式 Taper type	尺寸(mm) Dimension						驱动环 Drivenring	键 Key	螺钉 Screw	扳手 Wrench	重量 (kg)
			dm	d	B	L1	L2	L					
BT40-XSL16-55	○	BT40	16	32	8	17	27	55	DXSL16	KXSL16	SXSL16	S6	1.21
-100	○	BT40	16	32	8	17	27	100	DXSL16	KXSL16	SXSL16	S6	1.49
-160	○	BT40	16	32	8	17	27	160	DXSL16	KXSL16	SXSL16	S6	1.80
BT40-XSL22-55	●	BT40	22	40	10	19	31	55	DXSL22	KXSL22	SXSL22	S8	1.39
-100	○	BT40	22	40	10	19	31	100	DXSL22	KXSL22	SXSL22	S8	1.80
-160	○	BT40	22	40	10	19	31	160	DXSL22	KXSL22	SXSL22	S8	2.32
BT40-XSL27-55	○	BT40	27	48	12	21	33	55	DXSL27	KXSL27	SXSL27	S10	1.61
-100	●	BT40	27	48	12	21	33	100	DXSL27	KXSL27	SXSL27	S10	2.20
-160	○	BT40	27	48	12	21	33	160	DXSL27	KXSL27	SXSL27	S10	2.99
BT40-XSL32-60	○	BT40	32	58	14	24	38	60	DXSL32	KXSL32	SXSL32	S12	1.86
-100	●	BT40	32	58	14	24	38	100	DXSL32	KXSL32	SXSL32	S12	2.86
-160	○	BT40	32	58	14	24	38	160	DXSL32	KXSL32	SXSL32	S12	4.05
BT40-XSL40-70	○	BT40	40	70	16	27	41	70	DXSL40	KXSL40	SXSL40	S14	2.78
-100	○	BT40	40	70	16	27	41	100	DXSL40	KXSL40	SXSL40	S14	3.45

订货示例: BT40-XSL16-55

● 常备库存 Unallocated stock ● 可备库存 Available stock ○ 订单生产 Order production

工具系统
热胀工具系统 SHRINK FIT HOLDER
HSK工具系统 HSK TOOL SYSTEM
TMG21工具系统 TMG21 TOOL SYSTEM
7:24工具系统 7:24 TOOL SYSTEM
其它工具系统 SPECIAL TOOL SYSTEM
附件 ACCESSORIES

D 工具系统 Tool System

套式立铣刀及三面刃铣刀刀柄-BT50
Shell Mill&Disc Mill Holder

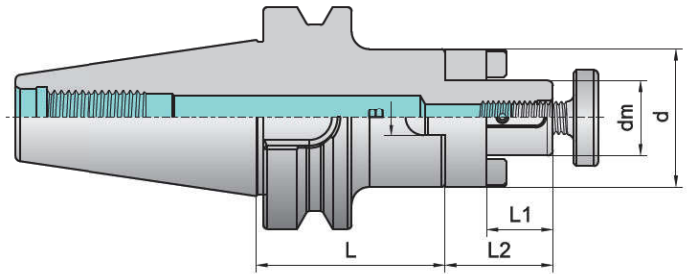
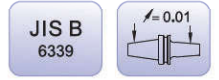

型号 Type	库存 Stock	锥柄型式 Taper type	尺寸(mm) Dimension						驱动环 Drivenring	键 Key	螺钉 Screw	扳手 Wrench	重量 (kg)
			dm	d	B	L1	L2	L					
BT50-XSL16-70	○	BT50	16	32	8	17	27	70	DXSL16	KXSL16	SXSL16	S6	3.88
-100	○	BT50	16	32	8	17	27	100	DXSL16	KXSL16	SXSL16	S6	3.96
-160	○	BT50	16	32	8	17	27	160	DXSL16	KXSL16	SXSL16	S6	4.33
BT50-XSL22-70	●	BT50	22	40	10	19	31	70	DXSL22	KXSL22	SXSL22	S8	3.97
-100	○	BT50	22	40	10	19	31	100	DXSL22	KXSL22	SXSL22	S8	4.29
-160	○	BT50	22	40	10	19	31	160	DXSL22	KXSL22	SXSL22	S8	4.84
BT50-XSL27-70	●	BT50	27	48	12	21	33	70	DXSL27	KXSL27	SXSL27	S10	4.29
-100	○	BT50	27	48	12	21	33	100	DXSL27	KXSL27	SXSL27	S10	4.7
-160	●	BT50	27	48	12	21	33	160	DXSL27	KXSL27	SXSL27	S10	5.55
BT50-XSL32-70	●	BT50	32	58	14	24	38	70	DXSL32	KXSL32	SXSL32	S12	4.59
-100	○	BT50	32	58	14	24	38	100	DXSL32	KXSL32	SXSL32	S12	5.16
-160	○	BT50	32	58	14	24	38	160	DXSL32	KXSL32	SXSL32	S12	6.34
BT50-XSL40-70	○	BT50	40	70	16	27	41	70	DXSL40	KXSL40	SXSL40	S14	5.19
-100	○	BT50	40	70	16	27	41	100	DXSL40	KXSL40	SXSL40	S14	6.05
-160	●	BT50	40	70	16	27	41	160	DXSL40	KXSL40	SXSL40	S14	7.80

订货示例: BT50-XSL16-70

● 常备库存 Unallocated stock ● 可备库存 Available stock ○ 订单生产 Order production

D 工具系统 Tool System

套式立铣刀及三面刃铣刀刀柄-JT40
Shell Mill&Disc Mill Holder

DIN
69871

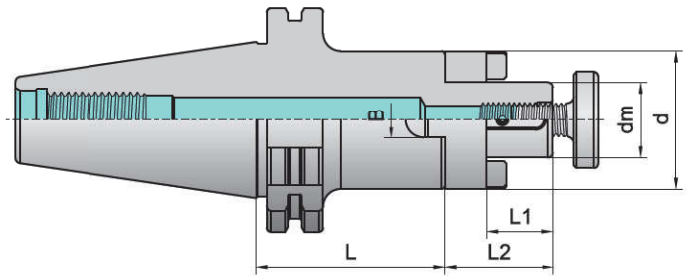
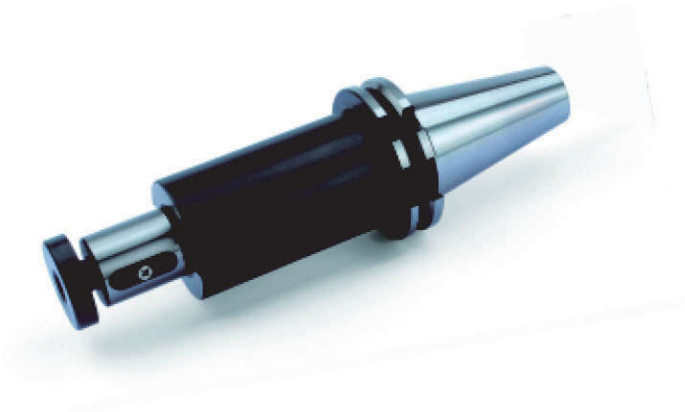
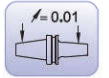

型号 Type	库存 Stock	锥柄型式 Taper type	尺寸(mm) Dimension						驱动环 Drivenring	键 Key	螺钉 Screw	扳手 Wrench	重量 (kg)
			dm	d	B	L1	L2	L					
JT40-XSL16-55	○	JT40	16	32	8	17	27	55	DXSL16	KXSL16	SXSL16	S6	
-100	○	JT40	16	32	8	17	27	100	DXSL16	KXSL16	SXSL16	S6	
-160	○	JT40	16	32	8	17	27	160	DXSL16	KXSL16	SXSL16	S6	1.40
JT40-XSL22-55	○	JT40	22	40	10	19	31	55	DXSL22	KXSL22	SXSL22	S8	
-100	○	JT40	22	40	10	19	31	100	DXSL22	KXSL22	SXSL22	S8	1.65
-160	○	JT40	22	40	10	19	31	160	DXSL22	KXSL22	SXSL22	S8	
JT40-XSL27-55	○	JT40	27	48	12	21	33	55	DXSL27	KXSL27	SXSL27	S10	
-100	○	JT40	27	48	12	21	33	100	DXSL27	KXSL27	SXSL27	S10	2.10
-160	○	JT40	27	48	12	21	33	160	DXSL27	KXSL27	SXSL27	S10	
JT40-XSL32-60	○	JT40	32	58	14	24	38	60	DXSL32	KXSL32	SXSL32	S12	
-100	○	JT40	32	58	14	24	38	100	DXSL32	KXSL32	SXSL32	S12	
-160	○	JT40	32	58	14	24	38	160	DXSL32	KXSL32	SXSL32	S12	
JT40-XSL40-60	○	JT40	40	70	16	27	41	60	DXSL40	KXSL40	SXSL40	S14	
-100	○	JT40	40	70	16	27	41	100	DXSL40	KXSL40	SXSL40	S14	

订货示例: JT40-XSL16-55

● 常备库存
Unallocated stock

◐ 可备库存
Available stock

○ 订单生产
Order production

D 工具系统 Tool System

套式立铣刀及三面刃铣刀刀柄-JT50
Shell Mill&Disc Mill Holder

DIN
69871

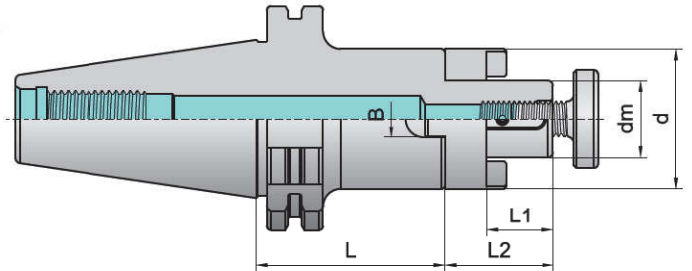
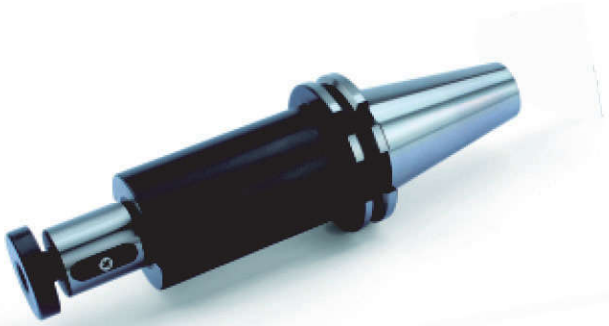
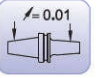

工具系统

SHRINK FIT HOLDER
热胀工具系统

HSK TOOL SYSTEM
HSK工具系统

TMG21 TOOL SYSTEM
TMG21工具系统

7:24 TOOL SYSTEM
7:24工具系统

SPECIAL TOOL SYSTEM
其它工具系统

ACCESSORIES
附件

型号 Type	库存 Stock	锥柄型式 Taper type	尺寸(mm) Dimension						驱动环 Drivenring	键 Key	螺钉 Screw	扳手 Wrench	重量 (kg)
			dm	d	B	L1	L2	L					
JT50-XSL16-55	○	JT50	16	32	8	17	27	55	DXSL16	KXSL16	SXSL16	S6	2.90
-100	○	JT50	16	32	8	17	27	100	DXSL16	KXSL16	SXSL16	S6	
-160	○	JT50	16	32	8	17	27	160	DXSL16	KXSL16	SXSL16	S6	
JT50-XSL22-55	○	JT50	22	40	10	19	31	55	DXSL22	KXSL22	SXSL22	S8	3.05
-100	○	JT50	22	40	10	19	31	100	DXSL22	KXSL22	SXSL22	S8	
-160	○	JT50	22	40	10	19	31	160	DXSL22	KXSL22	SXSL22	S8	4.05
JT50-XSL27-55	○	JT50	27	48	12	21	33	55	DXSL27	KXSL27	SXSL27	S10	3.23
-100	○	JT50	27	48	12	21	33	100	DXSL27	KXSL27	SXSL27	S10	
-160	○	JT50	27	48	12	21	33	160	DXSL27	KXSL27	SXSL27	S10	4.65
JT50-XSL32-55	●	JT50	32	58	14	24	38	55	DXSL32	KXSL32	SXSL32	S12	3.71
-100	○	JT50	32	58	14	24	38	100	DXSL32	KXSL32	SXSL32	S12	4.54
-160	○	JT50	32	58	14	24	38	160	DXSL32	KXSL32	SXSL32	S12	5.66
JT50-XSL40-55	○	JT50	40	70	16	27	41	55	DXSL40	KXSL40	SXSL40	S14	4.33
-100	○	JT50	40	70	16	27	41	100	DXSL40	KXSL40	SXSL40	S14	5.30
-160	○	JT50	40	70	16	27	41	160	DXSL40	KXSL40	SXSL40	S14	

订货示例: JT50-XSL16-55

D 工具系统 Tool System

三面刃铣刀刀柄-BT40/BT50
Disc Cutter Holders

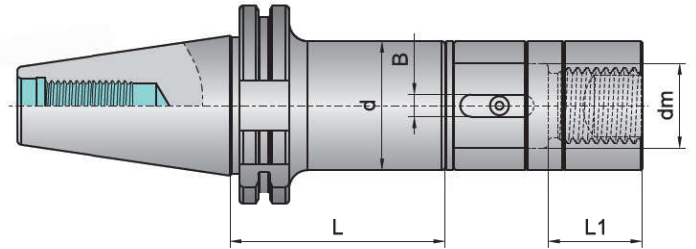

型号 Type	库存 Stock	锥柄型式 Taper type	尺寸(mm) Dimension					三面刃铣刀直径 Slotting cutter dia.	锯片铣刀直径 Disc dia.	键 Key	垫圈(成组) Shim set	螺母 Nut	重量 (kg)
			dm	d	B	L1	L						
BT40-XS13-60	○	BT40	13	20	-	15	60	-	50	-	GXS13	NXS13	1.15
-90	●	BT40	13	20	-	15	90	-	50	-	GXS13	NXS13	1.45
BT40-XS16-75	●	BT40	16	27	4	20	75	50	63	KXS16	GXS16	NXS16	1.59
-105	●	BT40	16	27	4	20	105	50	63	KXS16	GXS16	NXS16	1.55
BT40-XS22-75	●	BT40	22	34	6	25	75	63	80、100、125	KXS22	GXS22	NXS22	
-120	●	BT40	22	34	6	25	120	63	80、100、125	KXS22	GXS22	NXS22	
BT40-XS27-75	●	BT40	27	41	7	30	75	80	100、125	KXS27	GXS27	NXS27	2.15
-120	●	BT40	27	41	7	30	120	80	100、125	KXS27	GXS27	NXS27	2.59
BT40-XS32-90	●	BT40	32	47	8	35	90	100、125	160、200、250	KXS32	GXS32	NXS32	2.80
BT50-XS13-75	○	BT50	13	20	-	15	75	-	50	-	GXS13	NXS13	
-105	○	BT50	13	20	-	15	105	-	50	-	GXS13	NXS13	3.95
BT50-XS16-90	○	BT50	16	27	4	20	90	50	63	KXS16	GXS16	NXS16	4.15
-120	○	BT50	16	27	4	20	120	50	63	KXS16	GXS16	NXS16	4.30
BT50-XS22-90	○	BT50	22	34	6	25	90	63	80、100、125	KXS22	GXS22	NXS22	4.50
-135	●	BT50	22	34	6	25	135	63	80、100、125	KXS22	GXS22	NXS22	4.82
BT50-XS27-90	●	BT50	27	41	7	30	90	80	100、125	KXS27	GXS27	NXS27	4.90
-135	●	BT50	27	41	7	30	135	80	100、125	KXS27	GXS27	NXS27	5.34
BT50-XS32-90	●	BT50	32	47	8	35	90	100、125	160、200、250	KXS32	GXS32	NXS32	2.80
-135	●	BT50	32	47	8	35	135	100、125	160、200、250	KXS32	GXS32	NXS32	6.00
BT50-XS40-90	○	BT50	40	55	10	40	90	160、200	315	KXS40	GXS40	NXS40	5.99
-135	●	BT50	40	55	10	40	135	160、200	315	KXS40	GXS40	NXS40	6.92

订货示例: BT40-XS13-60

● 常备库存 Unallocated stock ● 可备库存 Available stock ○ 订单生产 Order production

D 工具系统 Tool System

三面刃铣刀刀柄-JT40/JT50 Disc Cutter Holders

DIN
69871

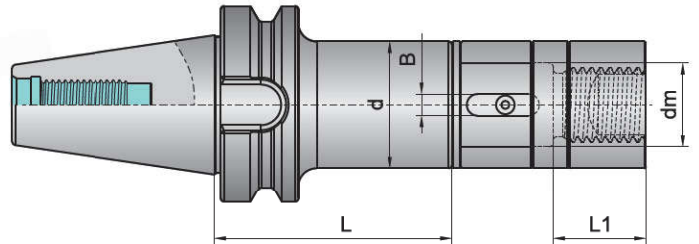
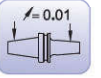

型号 Type	库存 Stock	锥柄型式 Taper type	尺寸(mm) Dimension					三面刃铣刀直径 Slotting cutter dia.	锯片铣刀直径 Disc dia.	键 Key	垫圈(成组) Shim set	螺母 Nut	重量 (kg)
			dm	d	B	L1	L						
JT40-XS13-60	○	JT40	13	20	-	15	60	-	50	-	GXS13	NXS13	1.05
-90	○	JT40	13	20	-	15	90	-	50	-	GXS13	NXS13	1.15
JT40-XS16-75	○	JT40	16	27	4	20	75	50	63	KXS16	GXS16	NXS16	1.30
-105	○	JT40	16	27	4	20	105	50	63	KXS16	GXS16	NXS16	1.40
JT40-XS22-75	○	JT40	22	34	6	25	75	63	80、100、125	KXS22	GXS22	NXS22	1.60
-120	○	JT40	22	34	6	25	120	63	80、100、125	KXS22	GXS22	NXS22	4.95
JT40-XS27-75	○	JT40	27	41	7	30	75	80	100、125	KXS27	GXS27	NXS27	2.05
-120	○	JT40	27	41	7	30	120	80	100、125	KXS27	GXS27	NXS27	
JT40-XS32-90	○	JT40	32	47	8	35	90	100、125	160、200、250	KXS32	GXS32	NXS32	
JT50-XS13-75	○	JT50	13	20	-	15	75	-	50	-	GXS13	NXS13	2.90
-105	○	JT50	13	20	-	15	105	-	50	-	GXS13	NXS13	2.95
JT50-XS16-90	○	JT50	16	27	4	20	90	50	63	KXS16	GXS16	NXS16	
-120	○	JT50	16	27	4	20	120	50	63	KXS16	GXS16	NXS16	3.45
JT50-XS22-90	○	JT50	22	34	6	25	90	63	80、100、125	KXS22	GXS22	NXS22	3.60
-135	○	JT50	22	34	6	25	135	63	80、100、125	KXS22	GXS22	NXS22	3.90
JT50-XS27-90	○	JT50	27	41	7	30	90	80	100、125	KXS27	GXS27	NXS27	4.06
-135	○	JT50	27	41	7	30	135	80	100、125	KXS27	GXS27	NXS27	4.55
JT50-XS32-90	○	JT50	32	47	8	35	90	100、125	160、200、250	KXS32	GXS32	NXS32	4.65
-135	○	JT50	32	47	8	35	135	100、125	160、200、250	KXS32	GXS32	NXS32	5.25
JT50-XS40-90	○	JT50	40	55	10	40	90	160、200	315	KXS40	GXS40	NXS40	5.41
-135	○	JT50	40	55	10	40	135	160、200	315	KXS40	GXS40	NXS40	6.19

订货示例: JT40-XS13-60

● 常备库存
Unallocated stock

● 可备库存
Available stock

○ 订单生产
Order production

D 工具系统 Tool System

有扁尾莫氏圆锥孔刀柄-BT30/BT40/BT50
Morse Taper Shank with Tang

DIN
69871

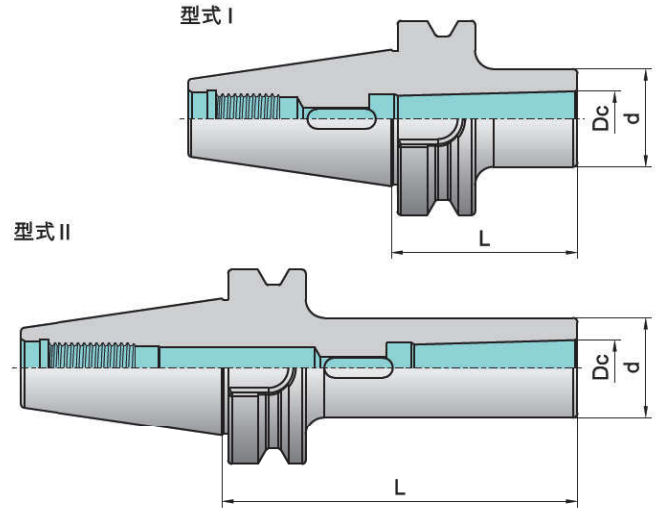
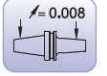

型号 Type	库存 Stock	锥柄型式 Taper type	莫氏锥度 Morse taper	尺寸(mm) Dimension			安装钻头直径 Drill bit dia.	型式 Model	重量 (kg)
				Dc	d	L			
BT30-M1-45	●	BT30	MT1	12.065	25	45	3~14	I	0.43
BT30-M2-60	○	BT30	MT2	17.78	32	60	14.25~23	I	0.50
BT40-M1-50	●	BT40	MT1	12.065	25	50	3~14	I	1.02
-120	●	BT40	MT1	12.065	25	120	3~14	II	1.29
BT40-M2-50	●	BT40	MT2	17.78	32	50	14.25~23	I	1.01
-120	●	BT40	MT2	17.78	32	120	14.25~23	II	1.41
BT40-M3-70	●	BT40	MT3	23.825	40	70	23.25~31.75	I	1.15
-135	●	BT40	MT3	23.825	40	135	23.25~31.75	II	1.73
BT40-M4-95	●	BT40	MT4	31.267	50	95	32~50.5	I	1.43
-165	●	BT40	MT4	31.267	50	165	32~50.5	II	2.40
BT50-M1-45	●	BT50	MT1	12.065	25	45	3~14	I	3.60
-120	●	BT50	MT1	12.065	25	120	3~14	II	3.83
-180	●	BT50	MT1	12.065	25	180	3~14	II	4.03
BT50-M2-60	●	BT50	MT2	17.78	32	60	14.25~23	I	3.63
-135	●	BT50	MT2	17.78	32	135	14.25~23	II	
-180	●	BT50	MT2	17.78	32	180	14.25~23	II	4.29
BT50-M3-65	●	BT50	MT3	23.825	40	65	23.25~31.75	I	3.40
-150	●	BT50	MT3	23.825	40	150	23.25~31.75	II	4.35
-180	●	BT50	MT3	23.825	40	180	23.25~31.75	II	4.61
BT50-M4-95	●	BT50	MT4	31.267	50	95	32~50.5	I	3.85
-180	●	BT50	MT4	31.267	50	180	32~50.5	II	5.06
BT50-M5-110	●	BT50	MT5	44.399	70	110	51~76	I	4.17

订货示例: BT30-M1-45

● 常备库存
Unallocated stock

◐ 可备库存
Available stock

○ 订单生产
Order production

D 工具系统 Tool System

有扁尾莫氏圆锥孔刀柄-JT40/JT50
Morse Taper Shank with Tang

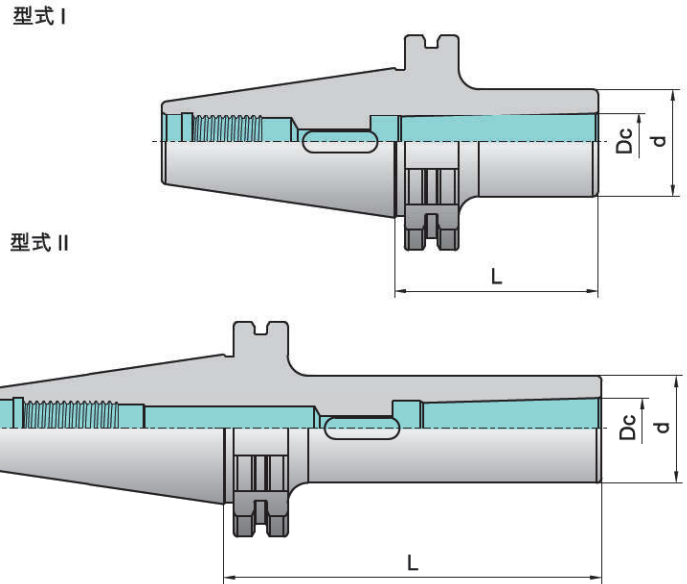
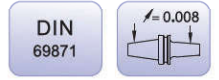

型号 Type	库存 Stock	锥柄型式 Taper type	莫氏锥度 Morse taper	尺寸(mm) Dimension			安装钻头直径 Drill bit dia.	型式 Model	重量 (kg)
				Dc	d	L			
JT40-M1-50	○	JT40	MT1	12.065	25	50	3~14	I	0.88
-120	○	JT40	MT1	12.065	25	120	3~14	II	1.13
JT40-M2-50	○	JT40	MT2	17.78	32	50	14.25~23	I	0.89
-120	○	JT40	MT2	17.78	32	120	14.25~23	II	1.29
JT40-M3-70	○	JT40	MT3	23.825	40	70	23.25~31.75	I	1.04
-135	○	JT40	MT3	23.825	40	135	23.25~31.75	II	1.62
JT40-M4-95	○	JT40	MT4	31.267	50	95	32~50.5	I	1.37
-165	○	JT40	MT4	31.267	50	165	32~50.5	II	2.34
JT50-M1-45	○	JT50	MT1	12.065	25	45	3~14	I	2.67
-120	○	JT50	MT1	12.065	25	120	3~14	II	2.94
-180	○	JT50	MT1	12.065	25	180	3~14	II	3.14
JT50-M2-60	●	JT50	MT2	17.78	32	60	14.25~23	I	2.73
-135	●	JT50	MT2	17.78	32	135	14.25~23	II	3.23
-180	○	JT50	MT2	17.78	32	180	14.25~23	II	3.35
JT50-M3-65	●	JT50	MT3	23.825	40	65	23.25~31.75	I	2.80
-150	●	JT50	MT3	23.825	40	150	23.25~31.75	II	3.57
-180	○	JT50	MT3	23.825	40	180	23.25~31.75	II	3.10
JT50-M4-70	●	JT50	MT4	31.267	50	70	32~50.5	I	2.85
-180	●	JT50	MT4	31.267	50	180	32~50.5	II	
JT50-M5-110	●	JT50	MT5	44.399	70	110	51~76	I	3.67

订货示例: JT40-M1-50

● 常备库存 Unallocated stock ● 可备库存 Available stock ○ 订单生产 Order production

D 工具系统 Tool System

无扁尾莫氏圆锥孔刀柄-BT40/BT50
Morse Taper Shank without Tang

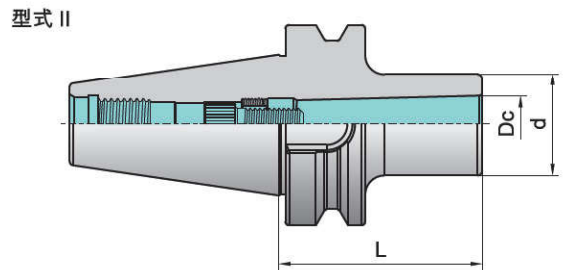
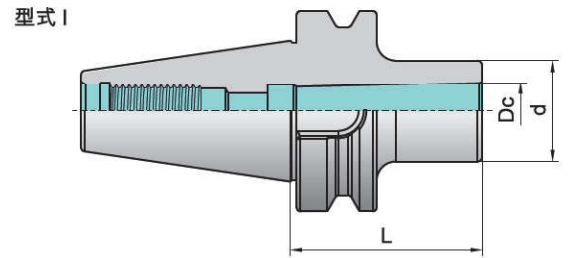
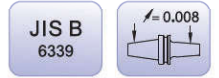

型号 Type	库存 Stock	锥柄型式 Taper type	莫氏锥度 Morse taper	尺寸(mm) Dimension			螺钉 Screw	扳手 Wrench	安装铣刀直径 Milling cutter dia.	型式 Model	重量 (kg)
				Dc	d	L					
BT40-MW1-50	●	BT40	MT1	12.065	27	50	SCC060250	S5	6~12	I	1.05
BT40-MW2-50	●	BT40	MT2	17.78	32	50	SCC100300A	S8	14~20	I	1.06
BT40-MW3-70	●	BT40	MT3	23.825	40	70	SCC120350A	S10	22~36	II	1.20
BT40-MW4-95	●	BT40	MT4	31.267	50	95	SCC160400B	S12	32~56	II	1.53
BT50-MW1-50	●	BT50	MT1	12.065	27	50	SCC060250	S5	6~12	I	3.62
BT50-MW2-60	●	BT50	MT2	17.78	32	60	SCC100300	S8	14~20	I	3.66
BT50-MW3-65	●	BT50	MT3	23.825	40	65	SCC120350	S10	22~36	I	3.80
BT50-MW4-70	●	BT50	MT4	31.267	50	70	SCC160400A	S14	32~56	I	3.71
BT50-MW5-105	●	BT50	MTM	44.399	78	105	SCC200450A	S17	40~71	II	4.86

订货示例: BT40-MW1-50

常备库存 Unallocated stock
 可备库存 Available stock
 订单生产 Order production

工具系统
 热胀工具系统 SHRINK FIT HOLDER
 HSK工具系统 HSK TOOL SYSTEM
 TMG21工具系统 TMG21 TOOL SYSTEM
 7:24工具系统 7:24 TOOL SYSTEM
 其它工具系统 SPECIAL TOOL SYSTEM
 附件 ACCESSORIES

D 工具系统 Tool System

无扁尾莫氏圆锥孔刀柄-JT40/JT50
Morse Taper Shank without Tang

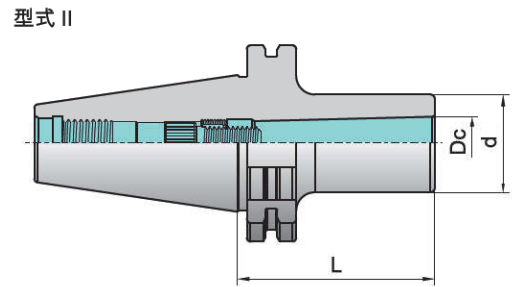
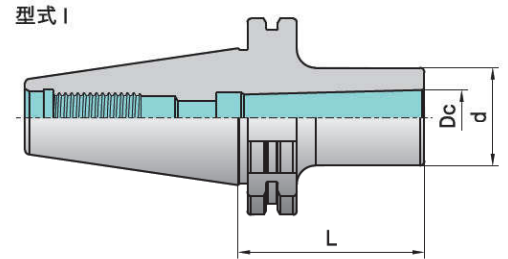
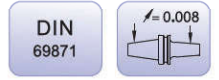

型号 Type	库存 Stock	锥柄型式 Taper type	莫氏锥度 Morse taper	尺寸(mm) Dimension			螺钉 Screw	扳手 Wrench	安装铣刀直径 Milling cutter dia.	型式 Model	重量 (kg)
				Dc	d	L					
JT40-MW1-45	○	JT40	MT1	12.065	27	45	SCC060250	S5	6~12	I	0.91
JT40-MW2-50	○	JT40	MT2	17.78	32	50	SCC100300A	S8	14~20	I	0.94
JT40-MW3-70	○	JT40	MT3	23.825	40	70	SCC120350A	S10	22~36	II	1.12
JT40-MW4-95	○	JT40	MT4	31.267	50	95	SCC160400B	S12	32~56	II	1.47
JT50-MW1-45	○	JT50	MT1	12.065	27	45	SCC060250	S5	6~12	I	2.69
JT50-MW2-60	●	JT50	MT2	17.78	32	60	SCC100300	S8	14~20	I	2.78
JT50-MW3-65	●	JT50	MT3	23.825	40	65	SCC120350	S10	22~36	I	2.89
JT50-MW4-70	●	JT50	MT4	31.267	50	70	SCC160400A	S14	32~56	I	3.08
JT50-MW5-105	○	JT50	MT5	44.399	78	105	SCC200450A	S17	40~71	II	4.51

订货示例: JT40-MW1-45

常备库存 Unallocated stock
 可备库存 Available stock
 订单生产 Order production

D 工具系统 Tool System

整体式钻夹头刀柄-BT30/BT40/BT50
Integral Drill Chucks

JIS B
6339

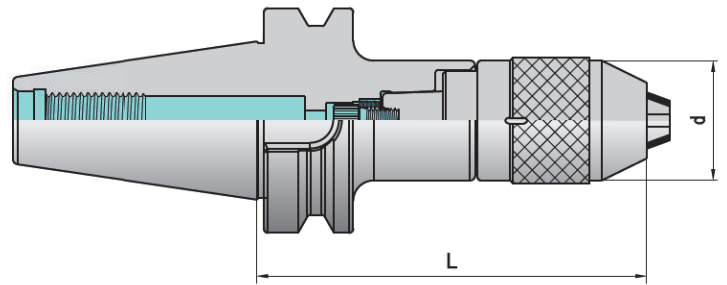

型号 Type	库存 Stock	锥柄型式 Taper type	尺寸(mm) Dimension		夹持范围 Holding range	扳手 Wrench	重量 (kg)
			d	L			
BT30-KPU08-75	○	BT30	37.5	75	0.5~8	WKPU08	
BT40-KPU08-80	●	BT40	37.5	80	0.5~8	WKPU08	1.28
BT40-KPU13-95	●	BT40	50.5	95	0.5~13	WKPU13	1.75
-150	●	BT40	50.5	150	0.5~13	WKPU13	2.47
BT40-KPU16-100	●	BT40	57	100	3~16	WKPU16	2.02
-150	○	BT40	57	150	3~16	WKPU16	2.87
BT50-KPU08-90	●	BT50	37.5	90	0.5~8	WKPU08	3.79
BT50-KPU13-105	●	BT50	50.5	105	0.5~13	WKPU13	4.35
-180	●	BT50	50.5	180	0.5~13	WKPU13	5.25
BT50-KPU16-110	●	BT50	57	110	3~16	WKPU16	4.61
-180	●	BT50	57	180	3~16	WKPU16	5.73

订货示例: BT30-KPU08-75

● 常备库存 Unallocated stock ● 可备库存 Available stock ○ 订单生产 Order production

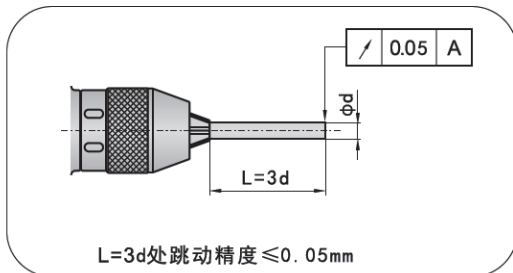

工具系统
热胀工具系统 SHRINK FIT HOLDER
HSK工具系统 HSK TOOL SYSTEM
TMG21工具系统 TMG21 TOOL SYSTEM
7:24工具系统 7:24 TOOL SYSTEM
其它工具系统 SPECIAL TOOL SYSTEM
附件 ACCESSORIES

D 工具系统 Tool System

整体式钻夹头刀柄-JT40/JT50
Integral Drill Chucks

DIN
69871

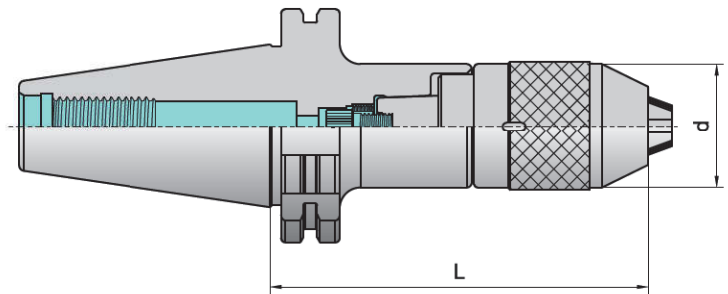

型号 Type	库存 Stock	锥柄型式 Taper type	尺寸(mm) Dimension		夹持范围 Holding range	扳手 Wrench	重量 (kg)
			d	L			
JT40-KPU08-70	○	JT40	37.5	70	0.5~8	WKPU08	1.12
JT40-KPU13-90	●	JT40	50.5	90	0.5~13	WKPU13	1.63
-150	○	JT40	50.5	150	0.5~13	WKPU13	
JT40-KPU16-105	○	JT40	57	105	3~16	WKPU16	2.04
JT50-KPU08-70	○	JT50	37.5	70	0.5~8	WKPU08	2.91
JT50-KPU13-85	○	JT50	50.5	85	0.5~13	WKPU13	3.37
-180	●	JT50	50.5	180	0.5~13	WKPU13	4.56
JT50-KPU16-90	○	JT50	57	90	3~16	WKPU16	3.62

订货示例: JT40-KPU08-70

● 常备库存 Unallocated stock ● 可备库存 Available stock ○ 订单生产 Order production

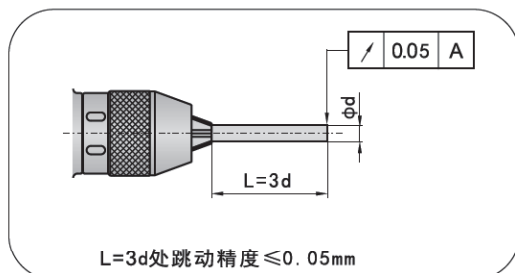

D 工具系统 Tool System

变径柄-BT40/BT50 Adapter Arbor

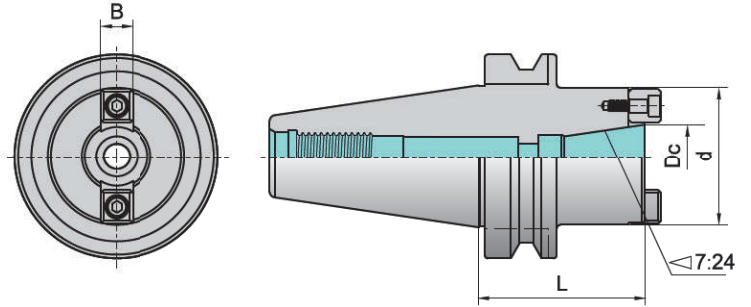

型号 Type	库存 Stock	锥柄型式 Taper type	尺寸(mm) Dimension				螺钉 Screw	扳手 Wrench	重量 (kg)
			Dc	d	B	L			
BT40-30-75	○	BT40	31.75	φ 67.5	16	75	SCC120350	S10	2.01
BT50-30-75	○	BT50	31.75	φ 67.5	16	75	SCC120350	S10	4.42
BT50-40-75	●	BT50	44.45	φ 89	16	75	SCC160400A	S14	4.81

订货示例: BT40-30-75

变径柄-JT40/50 Adapter Arbor

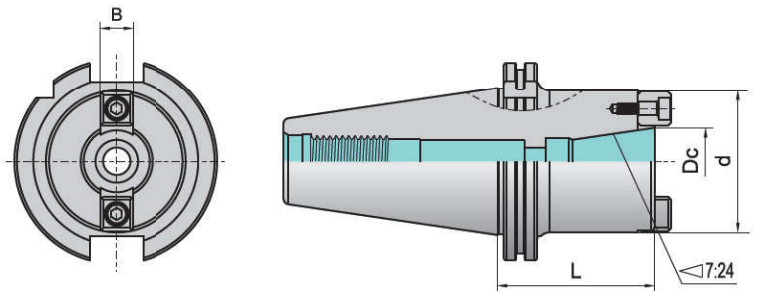

型号 Type	库存 Stock	锥柄型式 Taper type	尺寸(mm) Dimension				螺钉 Screw	扳手 Wrench	重量 (kg)
			Dc	d	B	L			
JT40-30-75	○	JT40	31.75	φ 67.5	16	75	SCC120350	S10	
JT50-30-75	○	JT50	31.75	φ 67.5	16	75	SCC120350	S10	3.90
JT50-40-75	○	JT50	44.45	φ 89	16	75	SCC160400A	S14	

订货示例: JT40-30-75

● 常备库存 Unallocated stock ● 可备库存 Available stock ○ 订单生产 Order production

工具系统
热胀工具系统 SHRINK FIT HOLDER
HSK工具系统 HSK TOOL SYSTEM
TMG21工具系统 TMG21 TOOL SYSTEM
7:24工具系统 7:24 TOOL SYSTEM
其它工具系统 SPECIAL TOOL SYSTEM
附件 ACCESSORIES

D 工具系统 Tool System

拉钉ISO7388 A型

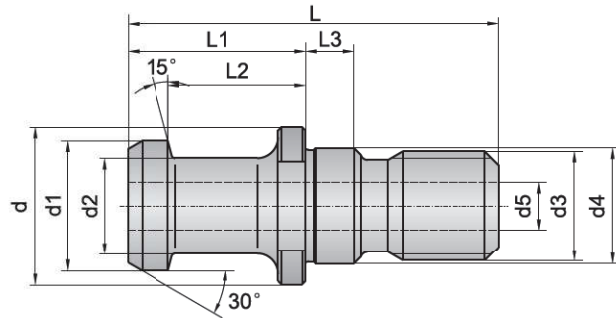

型号 Type	库存 Stock	尺寸(mm) Dimension										重量 (kg)
		L	L1	L2	L3	d	d1	d2	d3	d4	d5	
LDA30	●	44	24	19	5	17	12	8	M12	13	-	0.05
LDA40	●	54	26	20	7	23	19	14	M16	17	-	0.07
LDA50	●	74	34	25	10	36	28	21	M24	25	-	0.22
LDA40C	●	54	26	20	7	23	19	14	M16	17	7	0.07
LDA50C	●	74	34	25	10	36	28	21	M24	25	11.5	0.22

订货示例:LDA30

拉钉ISO7388 B型

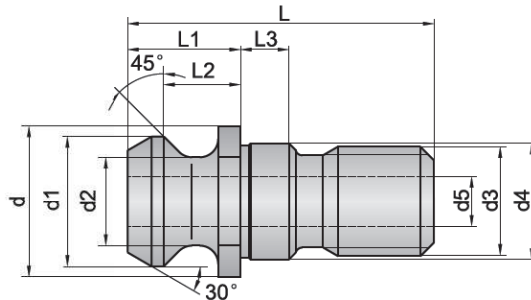

型号 Type	库存 Stock	尺寸(mm) Dimension										重量 (kg)
		L	L1	L2	L3	d	d1	d2	d3	d4	d5	
LDB30	●	27	11.8	8.1	5	17	13.3	9.3	M12	13	-	0.05
LDB40	●	44.5	16.4	11.15	7	22.5	18.95	12.95	M16	17	-	0.07
LDB50	●	66.5	25.55	17.95	10	36	29.1	19.6	M24	25	-	0.22
LDB40C	●	44.5	16.4	11.15	7	22.5	18.95	12.95	M16	17	7	0.07
LDB50C	●	66.5	25.55	17.95	10	36	29.1	19.6	M24	25	11.5	0.22

订货示例:LDB30

● 常备库存
Unallocated stock

● 可备库存
Available stock

○ 订单生产
Order production

D 工具系统 Tool System

拉钉DIN69872

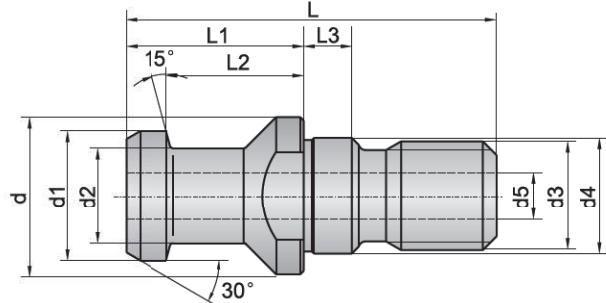

型号 Type	库存 Stock	尺寸(mm) Dimension										重量 (kg)
		L	L1	L2	L3	d	d1	d2	d3	d4	d5	
D30	●	44	24	19	5	17	13	9	M12	13	-	0.05
D40	●	54	26	20	7	23	19	14	M16	17	-	0.07
D50	●	74	34	25	10	36	28	21	M24	25	-	0.20
D40C	●	54	26	20	7	23	19	14	M16	17	7	0.07
D50C	●	74	34	25	10	36	28	21	M24	25	11.5	0.20

订货示例: D30

拉钉ANSI B5.50

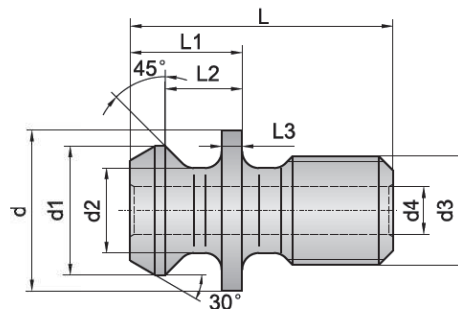

型号 Type	库存 Stock	尺寸(mm) Dimension									重量 (kg)
		L	L1	L2	L3	d	d1	d2	d3	d4	
A30	●	27.94	11.684	8.128	2.54	16.51	13.208	9.779	1/2-13 UNC	-	0.02
A40	●	38.1	16.256	11.176	3.048	23.876	18.796	12.446	5/8-11 UNC	-	0.05
A50	●	58.42	25.4	17.78	5.08	36.576	28.956	20.828	1/8 UNC	-	0.20
A30C	●	27.94	11.684	8.128	2.54	16.51	13.208	9.779	1/2-13 UNC	4.75	0.02
A40C	●	38.1	16.256	11.176	3.048	23.876	18.796	12.446	5/8-11 UNC	7.14	0.05
A50C	●	58.42	25.4	17.78	5.08	36.576	28.956	20.828	1/8 UNC	11.89	0.20

订货示例: A30

● 常备库存
Unallocated stock

● 可备库存
Available stock

○ 订单生产
Order production

D 工具系统 Tool System

拉钉MAS403-1975

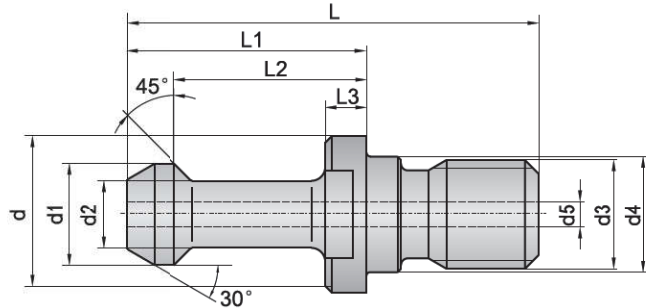

型号 Type	库存 Stock	尺寸(mm) Dimension										重量 (kg)
		L	L1	L2	L3	d	d1	d2	d3	d4	d5	
P30T-I	●	43	23	18	5	16.5	11	7	M12	12.5	-	0.03
P40T-I	●	60	35	28	6	23	15	10	M16	17	-	0.06
P50T-I	●	85	45	35	10	38	23	17	M24	25	-	0.26
P40T-IC	●	60	35	28	6	23	15	10	M16	17	4	0.06
P50T-IC	●	85	45	35	10	38	23	17	M24	25	6	0.26

订货示例: P30T- I

拉钉MAS403-1975

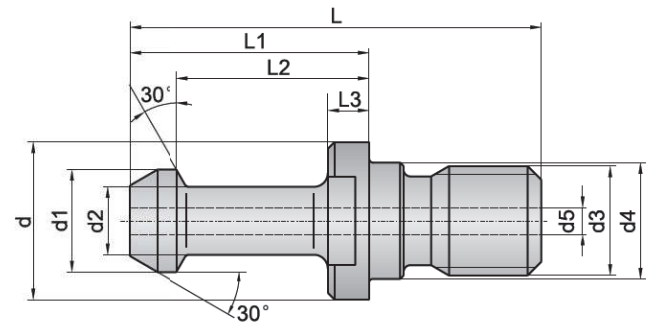

型号 Type	库存 Stock	尺寸(mm) Dimension										重量 (kg)
		L	L1	L2	L3	d	d1	d2	d3	d4	d5	
P30T-II	●	43	23	18	5	16.5	11	7	M12	12.5	-	0.03
P40T-II	●	60	35	28	6	23	15	10	M16	17	-	0.06
P50T-II	●	85	45	35	10	38	23	17	M24	25	-	0.26
P40T-IIC	●	60	35	28	6	23	15	10	M16	17	4	0.06
P50T-IIC	●	85	45	35	10	38	23	17	M24	25	6	0.26

订货示例: P30T- II

● 常备库存
Unallocated stock

◐ 可备库存
Available stock

○ 订单生产
Order production

D 工具系统 Tool System

拉钉MAS430-1975

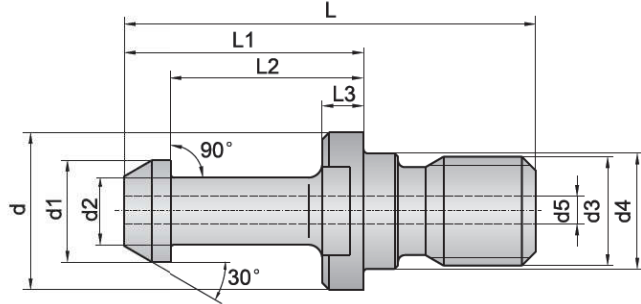

型号 Type	库存 Stock	尺寸(mm) Dimension										重量 (kg)
		L	L1	L2	L3	d	d1	d2	d3	d4	d5	
P30	●	43	23	18	5	16.5	11	7	M12	12.5	-	0.03
P40	●	60	35	28	6	23	15	10	M16	17	-	0.06
P50	●	85	45	35	10	38	23	17	M24	25	-	0.26
P40C	●	60	35	28	6	23	15	10	M16	17	4	0.06
P50C	●	85	45	35	10	38	23	17	M24	25	6	0.26

订货示例:P30

MAZAK拉钉

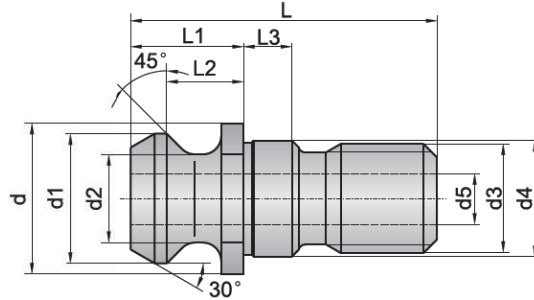

型号 Type	库存 Stock	尺寸 Dimension(mm)										重量 (kg)
		L	L1	L2	L3	d	d1	d2	d3	d4	d5	
MAZAK-BT40	⊙	44.1	19.1	14.02	7	22	18.80	12.45	M16	17	-	
MAZAK-BT50	⊙	65.2	25.2	17.7	10	37	28.96	20.83	M24	25	-	
MAZAK-BT40C	⊙	44.1	19.1	14.02	7	22	18.80	12.45	M16	17	7	
MAZAK-BT50C	⊙	65.2	25.2	17.7	10	37	28.96	20.83	M24	25	10	

订货示例:MAZAK-BT40

● 常备库存 Unallocated stock ● 可备库存 Available stock ○ 订单生产 Order production

D 工具系统 Tool System

ST转接拉钉

DIN2080标准刀柄替代方案：

降低刀柄库存！！

只需要相应的拉钉和键即可实现

BT刀柄（JIS B6339标准）转化为ST接口刀柄
（DIN2080标准）

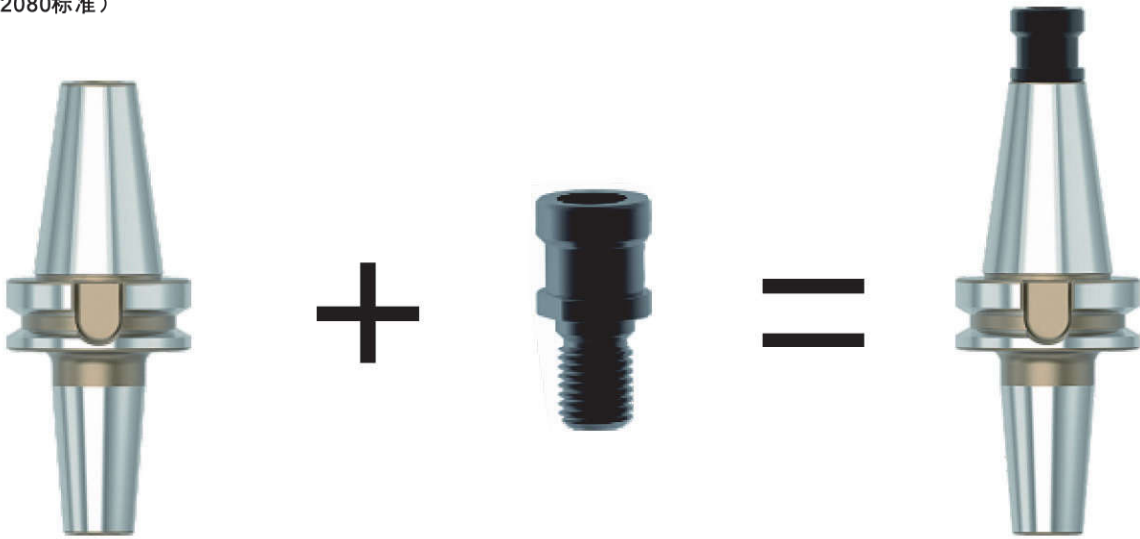

JT刀柄（DIN69871标准）转化为ST接口刀柄
（DIN2080标准）

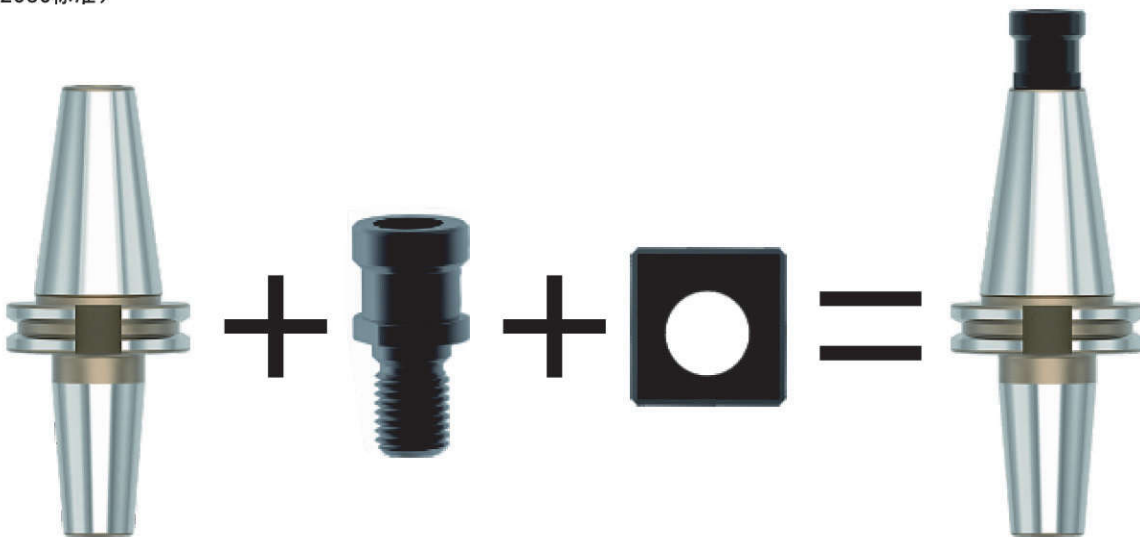

D 工具系统 Tool System

ST转接拉钉

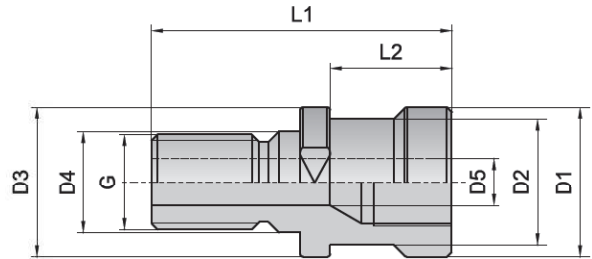

型号 Type	库存 Stock	尺寸(mm) Dimension								适用于 Apply to	重量 (kg)
		G	D1	D2	D3	D4/g6	D5	L1	L2		
LD-ST40	●	M16	25	21.1	25	17	7.5	53	25	SK40	

订货示例: LD-ST40

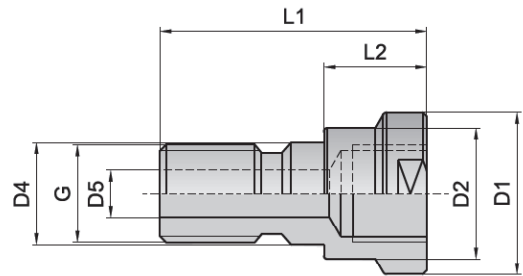

型号 Type	库存 Stock	尺寸(mm) Dimension								适用于 Apply to	重量 (kg)
		G	D1	D2	D3	D4/g6	D5	L1	L2		
LD-ST50	●	M24	39.6	32	25	-	11.5	65.1	25.1	SK50	

订货示例: LD-ST50

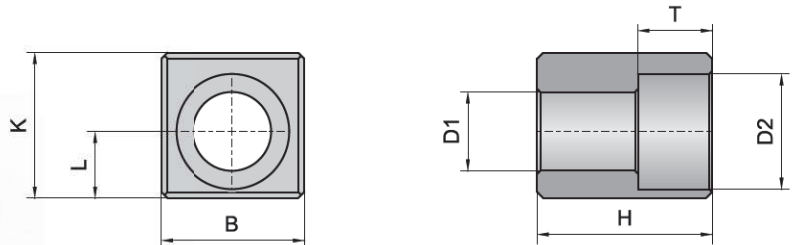

型号 Type	库存 Stock	尺寸(mm) Dimension							螺栓 Screw	适用于 Apply to	重量 (kg)
		K	B	D1	D2	T	H	L			
KST40	●	16.5	15.9	6.4	10.4	6.2	24.5	7	M6x25	SK40	
KST50	●	24	25.4	13	19	12.3	29	11	M12x30	SK50	

订货示例: KST40

● 常备库存
Unallocated stock

● 可备库存
Available stock

○ 订单生产
Order production

D 工具系统 Tool System

工具系统

SHRINK FIT HOLDER
热胀工具系统

HSK TOOL SYSTEM
HSK工具系统

TMG21 TOOL SYSTEM
TMG21工具系统

7:24 TOOL SYSTEM
7:24工具系统

SPECIAL TOOL SYSTEM
其它工具系统

ACCESSORIES
附件

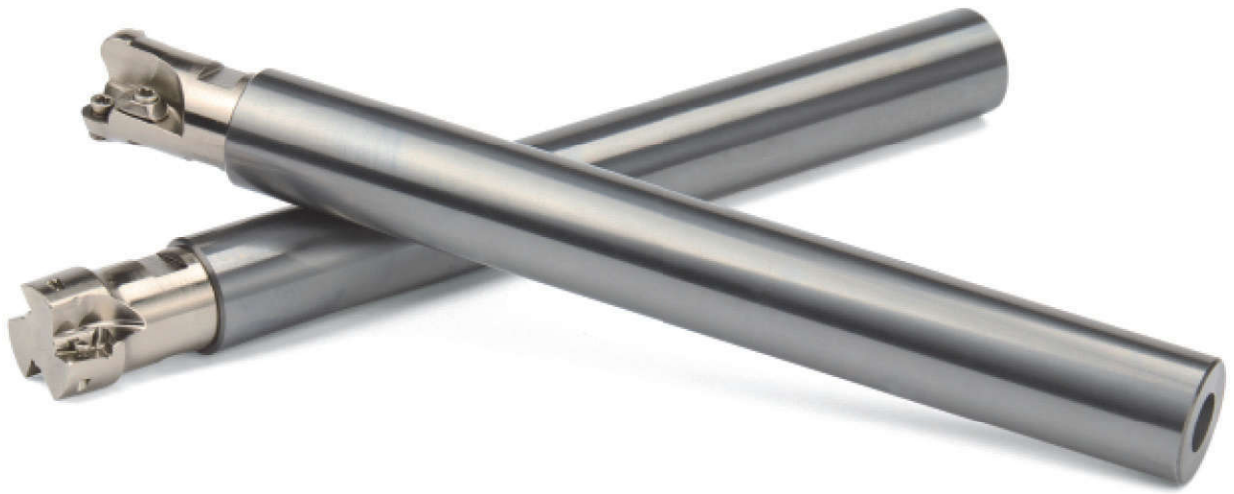

D 工具系统 Tool System

DM 模块式刀具配置图 DM Modular Tool Configuration Diagram

模块式铣刀

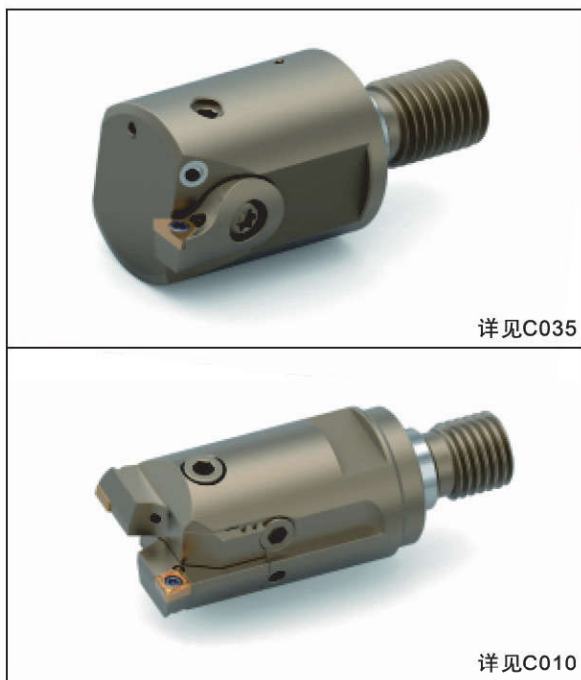

手柄和延长杆

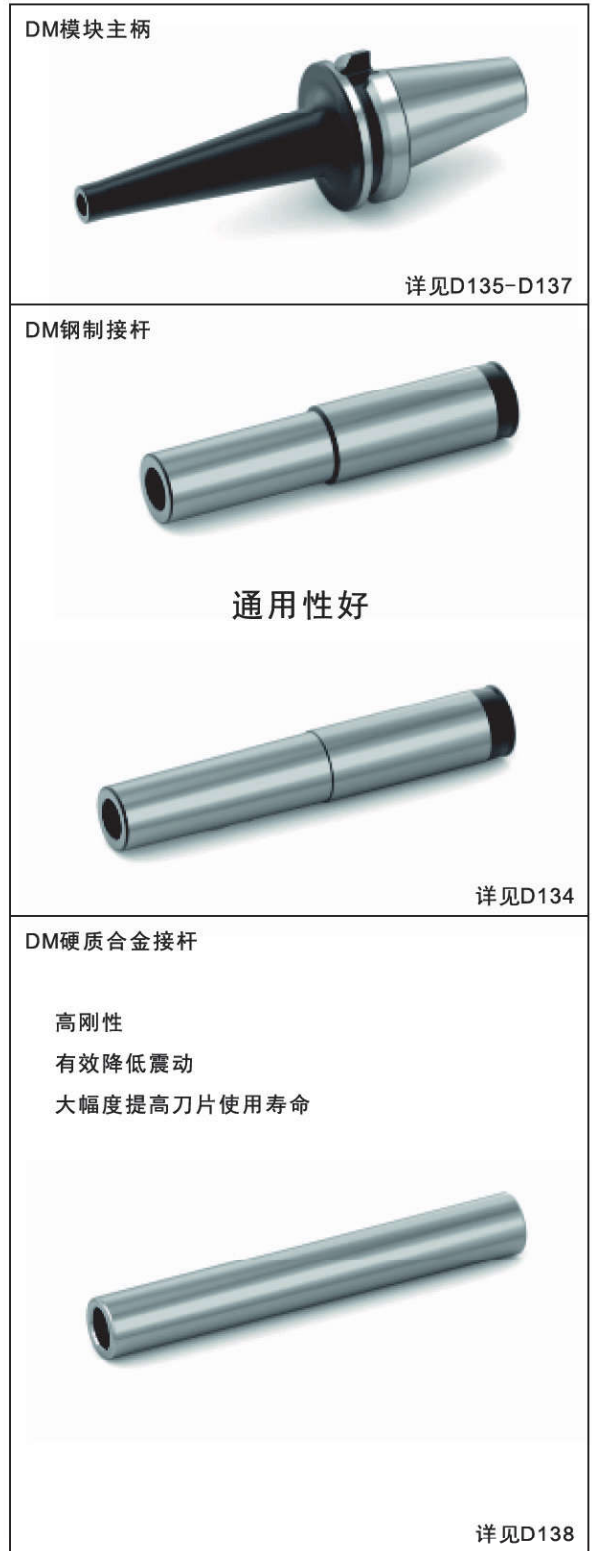

工具系统
HSK工具系统
HSK TOOL SYSTEM
热胀工具系统
SHRINK FIT HOLDER
TMG21工具系统
TMG21 TOOL SYSTEM
7:24工具系统
7:24 TOOL SYSTEM
其它工具系统
SPECIAL TOOL SYSTEM
附件
ACCESSORIES

D 工具系统 Tool System

DM 模块主柄
DM Modular Arbor

加工方式

台阶加工

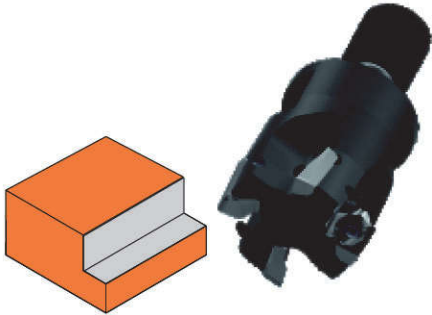

切槽加工

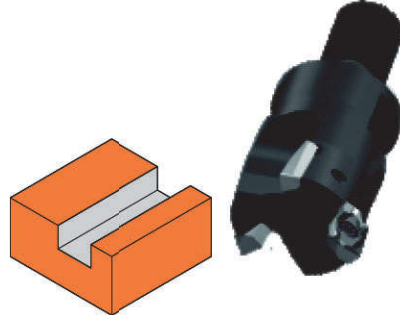

台阶加工使用能提高进给和效率的多刀片密齿刀具，切槽加工使用降低切削阻力的的少刀片疏齿刀具

组合型刀头的安装方法

1请确认刀头及刀柄的紧固部位没有切屑和脏物等附着（图1）紧固部位请勿涂抹润滑剂等。



图1

2请将刀头安装在刀柄上，并用扳手拧紧（图2）推荐紧固扭矩请见表1
注：产品中不带扳手

表1刀头的推荐紧固扭矩

配合螺纹直径	扳手双面宽度	推荐紧固扭矩[N. m]
M6	7	15
M8	10	23
M10	15	46
M12	17	80
M16	22	90



扳手尺寸及推荐紧固扭矩请参阅表1

图2

3请确认是否有间隙（图3）



图3

D 工具系统 Tool System

DM 钢制接杆 Steel Extension for DM Milling Cutters

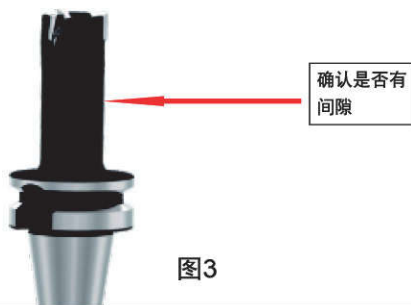
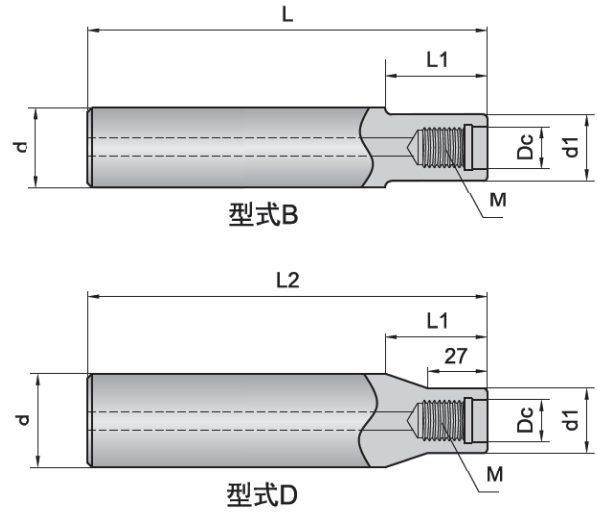
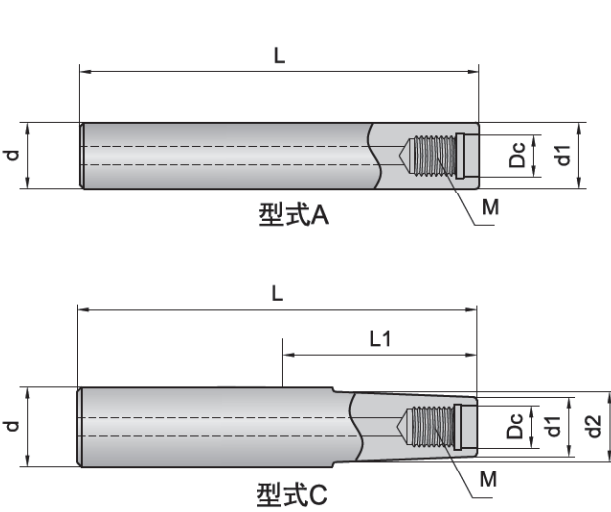

型号 Type	库存 Stock	尺寸(mm) Dimension							型式 Model	适用刀具 Applicable tool	内冷状态 Cooling	重量 (kg)
		Dc	M	d	d1	d2	L1	L				
A10-DM6L75	●	6.5	M6	10	-	-	-	75	A	∅10、∅12	+	
A12-DM6L85	●	6.5	M6	12	9.8	-	4	85	B	∅10、∅12	+	
A16-DM8L95	●	8.5	M8	16	14.5	15.5	15	95	C	∅16、∅18	+	
A20-DM10L100	●	10.5	M10	20	17.8	-	20	100	B	∅20、∅22	+	
A25-DM12L115	●	12.5	M12	25	23	-	35	115	B	∅25、∅28	+	
A32-DM16L110	●	17	M16	32	28.8	-	30	110	B	∅30、∅32、∅35、∅40	+	
A42-DM16L360	●	17	M16	42	28.8	-	90	360	D	∅30、∅32、∅35、∅40	+	

订货示例: A10-DM6L75

● 常备库存 Unallocated stock ● 可备库存 Available stock ○ 订单生产 Order production

工具系统
热胀工具系统 SHRINK FIT HOLDER
HSK工具系统 HSK TOOL SYSTEM
TMG21工具系统 TMG21 TOOL SYSTEM
7:24工具系统 7:24 TOOL SYSTEM
其它工具系统 SPECIAL TOOL SYSTEM
附件 ACCESSORIES

D 工具系统 Tool System

DM 模块主柄-BT30
DM Modular Arbor

JIS B
6339

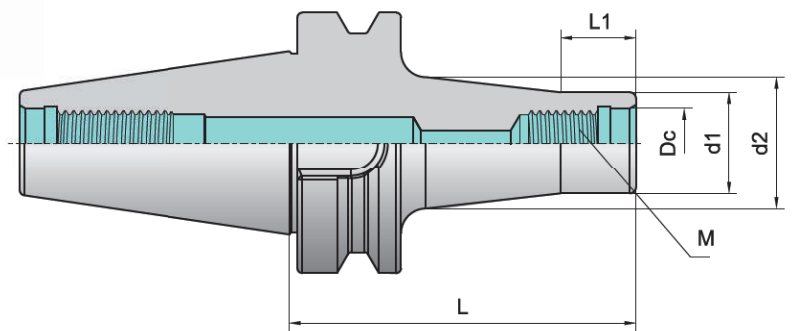
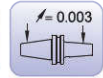

型号 Type	库存 Stock	尺寸(mm) Dimension						适用刀具 Applicable tool	内冷状态 Cooling	重量 (kg)
		Dc	M	d1	d2	L1	L			
BT30-DM6-50	●	6.5	M6	9.8	25	5	50	∅8、∅10、∅12	+	
BT30-DM6-80	●	6.5	M6	9.8	25	10	80	∅8、∅10、∅12	+	
BT30-DM6-100	●	6.5	M6	9.8	25	10	100	∅8、∅10、∅12	+	
BT30-DM8-50	●	8.5	M8	14.5	30	5	50	∅16、∅18	+	
BT30-DM8-70	●	8.5	M8	14.5	30	10	70	∅16、∅18	+	
BT30-DM8-100	●	8.5	M8	14.5	30	10	100	∅16、∅18	+	
BT30-DM10-40	●	10.5	M10	17.8	35	5	40	∅20、∅22	+	
BT30-DM10-70	●	10.5	M10	17.8	35	10	70	∅20、∅22	+	
BT30-DM10-90	●	10.5	M10	17.8	35	10	90	∅20、∅22	+	
BT30-DM12-40	●	12.5	M12	23	40	5	40	∅25、∅28	+	
BT30-DM12-60	●	12.5	M12	23	40	10	60	∅25、∅28	+	
BT30-DM12-90	●	12.5	M12	23	40	10	90	∅25、∅28	+	
BT30-DM12-110	●	12.5	M12	23	40	10	110	∅25、∅28	+	
BT30-DM16-30	●	17	M16	28.8	40	5	30	∅30、∅32、∅35、∅40	+	
BT30-DM16-60	●	17	M16	28.8	40	10	60	∅30、∅32、∅35、∅40	+	
BT30-DM16-80	●	17	M16	28.8	40	10	80	∅30、∅32、∅35、∅40	+	

订货示例: BT30-DM6-50

● 常备库存
Unallocated stock

● 可备库存
Available stock

○ 订单生产
Order production

D 工具系统 Tool System

DM 模块主柄-BT40
DM Modular Arbor

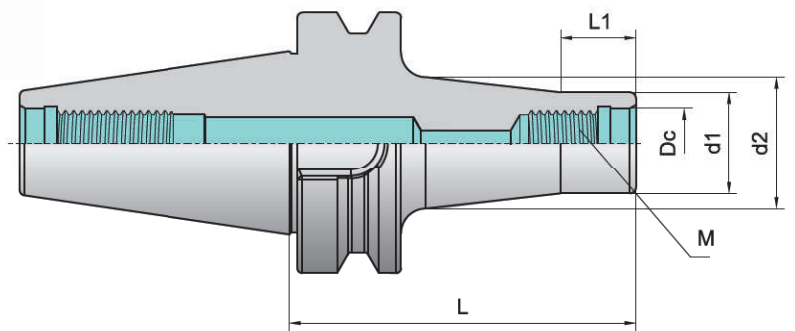
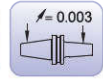

型号 Type	库存 Stock	尺寸(mm) Dimension						适用刀具 Applicable tool	内冷状态 Cooling	重量 (kg)
		Dc	M	d1	d2	L1	L			
BT40-DM6-60	●	6.5	M6	9.8	25	5	60	∅8、∅10、∅12	+	
BT40-DM6-80	●	6.5	M6	9.8	25	10	80	∅8、∅10、∅12	+	
BT40-DM6-110	●	6.5	M6	9.8	25	10	110	∅8、∅10、∅12	+	
BT40-DM6-160	●	6.5	M6	9.8	25	10	160	∅8、∅10、∅12	+	
BT40-DM8-50	●	8.5	M8	14.5	30	5	50	∅16、∅18	+	
BT40-DM8-80	●	8.5	M8	14.5	30	10	80	∅16、∅18	+	
BT40-DM8-100	●	8.5	M8	14.5	30	10	100	∅16、∅18	+	
BT40-DM8-150	●	8.5	M8	14.5	30	10	150	∅16、∅18	+	
BT40-DM10-50	●	10.5	M10	17.8	35	5	50	∅20、∅22	+	
BT40-DM10-70	●	10.5	M10	17.8	35	10	70	∅20、∅22	+	
BT40-DM10-100	●	10.5	M10	17.8	35	10	100	∅20、∅22	+	
BT40-DM10-150	●	10.5	M10	17.8	35	10	150	∅20、∅22	+	
BT40-DM12-40	●	12.5	M12	23	40	5	40	∅25、∅28	+	
BT40-DM12-70	●	12.5	M12	23	40	10	70	∅25、∅28	+	
BT40-DM12-90	●	12.5	M12	23	40	10	90	∅25、∅28	+	
BT40-DM12-140	●	12.5	M12	23	40	10	140	∅25、∅28	+	
BT40-DM16-40	●	17	M16	28.8	48	5	40	∅30、∅32、∅35、∅40	+	
BT40-DM16-60	●	17	M16	28.8	48	10	60	∅30、∅32、∅35、∅40	+	
BT40-DM16-90	●	17	M16	28.8	48	10	90	∅30、∅32、∅35、∅40	+	
BT40-DM16-140	●	17	M16	28.8	48	10	140	∅30、∅32、∅35、∅40	+	

订货示例: BT40-DM6-60

● 常备库存
Unallocated stock

● 可备库存
Available stock

○ 订单生产
Order production

D 工具系统 Tool System

DM 模块主柄-HSK63A
DM Modular Arbor

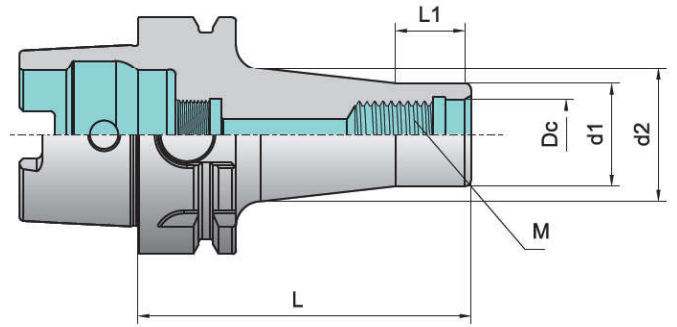

工具系统

SHRINK FIT HOLDER
热胀工具系统

HSK TOOL SYSTEM
HSK工具系统

TMG21 TOOL SYSTEM
TMG21工具系统

7:24 TOOL SYSTEM
7:24工具系统

SPECIAL TOOL SYSTEM
其它工具系统

ACCESSORIES
附件

型号Type	库存Stock	尺寸(mm) Dimension						适用刀具 Applicable tool	内冷状态 Cooling	重量 (kg)
		Dc	M	d1	d2	L1	L			
HSK63A-DM10-60	●	10.5	M10	17.8	20.8	-	60	Ø20、Ø22	+	
HSK63A-DM10-100	●	10.5	M10	17.8	25	10	100	Ø20、Ø22	+	
HSK63A-DM10-100S	●	10.5	M10	17.8	48	10	100	Ø20、Ø22	+	
HSK63A-DM10-150	●	10.5	M10	17.8	30.2	10	150	Ø20、Ø22	+	
HSK63A-DM12-60	●	12.5	M12	23	24.3	-	60	Ø25、Ø28	+	
HSK63A-DM12-90	●	12.5	M12	23	27.5	10	90	Ø25、Ø28	+	
HSK63A-DM12-90S	●	12.5	M12	23	48	10	90	Ø25、Ø28	+	
HSK63A-DM12-140	●	12.5	M12	23	32.7	10	140	Ø25、Ø28	+	
HSK63A-DM16-70	●	17	M16	28.8	31.8	-	70	Ø30、Ø32、Ø35、Ø40	+	
HSK63A-DM16-90	●	17	M16	28.8	33.9	10	90	Ø30、Ø32、Ø35、Ø40	+	
HSK63A-DM16-90S	●	17	M16	28.8	48	10	90	Ø30、Ø32、Ø35、Ø40	+	
HSK63A-DM16-140	●	17	M16	28.8	39.2	10	140	Ø30、Ø32、Ø35、Ø40	+	

订货示例: HSK63A-DM10-60

● 常备库存 Unallocated stock
● 可备库存 Available stock
○ 订单生产 Order production

D 工具系统 Tool System

DM 硬质合金接杆

Carbide Extension for DM Milling Cutters

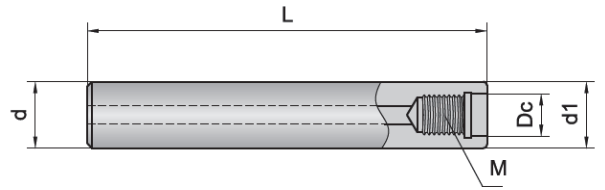

型号 Type	库存 Stock	尺寸(mm) Dimension						适用刀具 Application tool	内冷状态 Cooling	重量 (kg)
		Dc	M	d1	d	L1	L			
E12-DM6L75	●	6.5	M6	12	12	-	75	Φ10、Φ12	+	
E12-DM6L100	●	6.5	M6	12	12	-	100	Φ10、Φ12	+	
E12-DM6L150	●	6.5	M6	12	12	-	150	Φ10、Φ12	+	
E12-DM6L200	●	6.5	M6	12	12	-	200	Φ10、Φ12	+	
E16-DM8L100	●	8.5	M8	16	16	-	100	Φ16、Φ18	+	
E16-DM8L150	●	8.5	M8	16	16	-	150	Φ16、Φ18	+	
E16-DM8L200	●	8.5	M8	16	16	-	200	Φ16、Φ18	+	
E16-DM8L250	●	8.5	M8	16	16	-	250	Φ16、Φ18	+	
E20-DM10L150	●	10.5	M10	20	20	-	150	Φ20、Φ22	+	
E20-DM10L200	●	10.5	M10	20	20	-	200	Φ20、Φ22	+	
E20-DM10L250	●	10.5	M10	20	20	-	250	Φ20、Φ22	+	
E20-DM10L300	●	10.5	M10	20	20	-	300	Φ20、Φ22	+	
E24-DM12L200	●	12.5	M12	24	24	-	200	Φ25、Φ28	+	
E24-DM12L250	●	12.5	M12	24	24	-	250	Φ25、Φ28	+	
E24-DM12L300	●	12.5	M12	24	24	-	300	Φ25、Φ28	+	
E25-DM12L150	●	12.5	M12	25	25	-	150	Φ25、Φ28	+	
E25-DM12L200	●	12.5	M12	25	25	-	200	Φ25、Φ28	+	
E25-DM12L250	●	12.5	M12	25	25	-	250	Φ25、Φ28	+	
E25-DM12L300	●	12.5	M12	25	25	-	300	Φ25、Φ28	+	
E32-DM16L150	●	17	M16	32	32	-	150	Φ30、Φ32、Φ35、Φ40	+	
E32-DM16L200	●	17	M16	32	32	-	200	Φ30、Φ32、Φ35、Φ40	+	
E32-DM16L250	●	17	M16	32	32	-	250	Φ30、Φ32、Φ35、Φ40	+	
E32-DM16L300	●	17	M16	32	32	-	300	Φ30、Φ32、Φ35、Φ40	+	
E32-DM16L400	●	17	M16	32	32	-	400	Φ30、Φ32、Φ35、Φ40	+	

订货示例: E12-DM6L75

● 常备库存
Unallocated stock

● 可备库存
Available stock

○ 订单生产
Order production

D 工具系统 Tool System

DM 硬质合金接杆
Carbide Extension for DM Milling Cutters

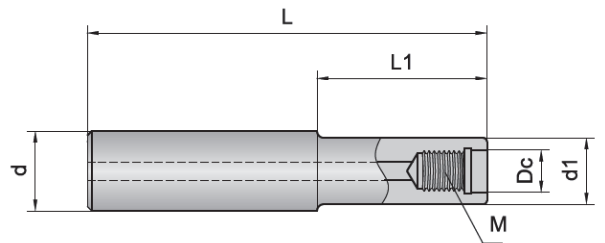

型号 Type	库存 Stock	尺寸(mm) Dimension						适用刀具 Application tool	内冷状态 Cooling	重量 (kg)
		Dc	M	d1	d	L1	L			
ES12-DM6L75	●	6.5	M6	11.5	12	30	75	Φ10、Φ12	+	
ES12-DM6L100	●	6.5	M6	11.5	12	50	100	Φ10、Φ12	+	
ES12-DM6L150	●	6.5	M6	11.5	12	80	150	Φ10、Φ12	+	
ES16-DM8L100	●	8.5	M8	15.5	16	50	100	Φ16、Φ18	+	
ES16-DM8L150	●	8.5	M8	15.5	16	90	150	Φ16、Φ18	+	
ES16-DM8L200	●	8.5	M8	15.5	16	115	200	Φ16、Φ18	+	
ES20-DM10L100	●	10.5	M10	19.5	20	40	100	Φ20、Φ22	+	
ES20-DM10L150	●	10.5	M10	19.5	20	90	150	Φ20、Φ22	+	
ES20-DM10L200	●	10.5	M10	19.5	20	135	200	Φ20、Φ22	+	
ES25-DM12L150	●	12.5	M12	24.0	25	90	150	Φ25、Φ28	+	
ES25-DM12L200	●	12.5	M12	24.0	25	115	200	Φ25、Φ28	+	
ES25-DM12L250	●	12.5	M12	24.0	25	135	250	Φ25、Φ28	+	
ES32-DM16L150	●	17	M16	30.0	32	90	150	Φ30、Φ32、Φ35、Φ40	+	
ES32-DM16L200	●	17	M16	30.0	32	115	200	Φ30、Φ32、Φ35、Φ40	+	
ES32-DM16L250	●	17	M16	30.0	32	135	250	Φ30、Φ32、Φ35、Φ40	+	
ES32-DM16L300	●	17	M16	30.0	32	180	300	Φ30、Φ32、Φ35、Φ40	+	

订货示例: ES12-DM6L75

● 常备库存 Unallocated stock ● 可备库存 Available stock ○ 订单生产 Order production

D 工具系统 Tool System

DM 硬质合金接杆

Carbide Extension for DM Milling Cutters

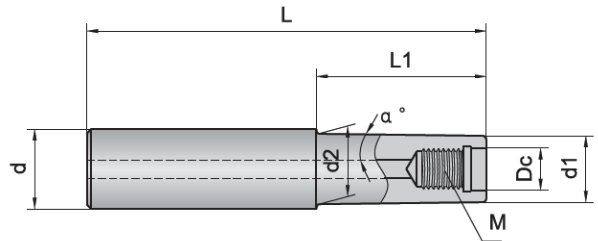

型号 Type	库存 Stock	尺寸(mm) Dimension							适用刀具 Application tool	内冷状态 Cooling	重量 (kg)
		Dc	M	d1	d	L1	L	α°			
ET16-DM6L150	●	6.5	M6	11.8	16	70	150	1.65	$\Phi 10$ 、 $\Phi 12$	+	
ET16-DM6L200	●	6.5	M6	11.8	16	90	200	1.3	$\Phi 10$ 、 $\Phi 12$	+	
ET16-DM6L250	●	6.5	M6	11.8	16	115	250	1	$\Phi 10$ 、 $\Phi 12$	+	
ET20-DM6L300	●	6.5	M6	11.8	20	135	300	1.7	$\Phi 10$ 、 $\Phi 12$	+	
ET20-DM8L200	●	8.5	M8	15.5	20	90	200	1.3	$\Phi 16$ 、 $\Phi 18$	+	
ET20-DM8L250	●	8.5	M8	15.5	20	115	250	1	$\Phi 16$ 、 $\Phi 18$	+	
ET20-DM8L300	●	8.5	M8	15.5	20	135	300	0.85	$\Phi 16$ 、 $\Phi 18$	+	
ET25-DM10L200	●	10.5	M10	19.8	25	90	200	1.6	$\Phi 20$ 、 $\Phi 22$	+	
ET25-DM10L250	●	10.5	M10	19.8	25	115	250	1.25	$\Phi 20$ 、 $\Phi 22$	+	
ET25-DM10L300	●	10.5	M10	19.8	25	135	300	1.1	$\Phi 20$ 、 $\Phi 22$	+	
ET32-DM12L200	●	12.5	M12	24.5	32	90	200	2.3	$\Phi 25$ 、 $\Phi 28$	+	
ET32-DM12L250	●	12.5	M12	24.5	32	115	250	1.75	$\Phi 25$ 、 $\Phi 28$	+	
ET32-DM12L300	●	12.5	M12	24.5	32	135	300	1.5	$\Phi 25$ 、 $\Phi 28$	+	

订货示例: ET16-DM6L150

● 常备库存
Unallocated stock

● 可备库存
Available stock

○ 订单生产
Order production

D 工具系统 Tool System

卡簧接杆 ER Chuck Extension

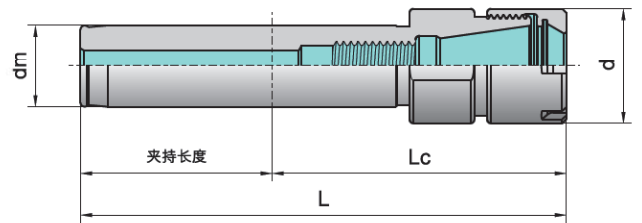

型号 Type	库存 Stock	尺寸(mm) Dimension				螺母 Nut	扳手 Wrench	卡簧 ERcollet	螺钉 Screw	重量 (kg)
		dm	d	Lc	L					
A16-ER11M-100	●	16	16	52	100	LN11M	WER11M	ER11	SGC060150	
-150	●	16	16	102	150	LN11M	WER11M	ER11	SGC060150	
-200	●	16	16	152	200	LN11M	WER11M	ER11	SGC060150	
A20-ER16M-100	●	20	22	50	100	LN16M	WER16M	ER16	SGC100150	
-150	●	20	22	100	150	LN16M	WER16M	ER16	SGC100150	
-200	●	20	22	150	200	LN16M	WER16M	ER16	SGC100150	
-250	●	20	22	200	250	LN16M	WER16M	ER16	SGC100150	
A20-ER20M-100	●	20	28	50	100	LN20M	WER20M	ER20	SGC120200	
-150	●	20	28	100	150	LN20M	WER20M	ER20	SGC120200	
-200	●	20	28	150	200	LN20M	WER20M	ER20	SGC120200	
-250	●	20	28	200	250	LN20M	WER20M	ER20	SGC120200	
A25-ER20M-100	○	25	28	44	100	LN20M	WER20M	ER20	SGC120200	
-150	●	25	28	94	150	LN20M	WER20M	ER20	SGC120200	
-200	○	25	28	144	200	LN20M	WER20M	ER20	SGC120200	
-250	●	25	28	194	250	LN20M	WER20M	ER20	SGC120200	
-300	●	25	28	244	300	LN20M	WER20M	ER20	SGC120200	

订货示例: A16-ER11M-100

● 常备库存 Unallocated stock ● 可备库存 Available stock ○ 订单生产 Order production

D 工具系统 Tool System

卡簧接杆 ER Chuck Extension

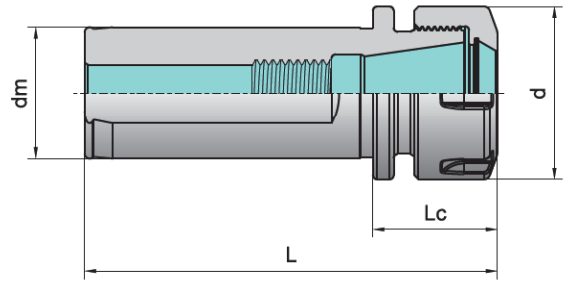

型号 Type	库存 Stock	尺寸(mm) Dimension				螺母 Nut	扳手 Wrench	卡簧 ERcollet	螺钉 Screw	重量 (kg)
		dm	d	Lc	L					
A32-ER16-100	○	32	32	30	100	LN16S	-	ER16	SGC100150	
A32-ER20-105	●	32	35	35	105	LN20S	-	ER20	SGC120200	
A32-ER25-105	●	32	42	35	105	LN25	WER25	ER25	SGC160200	
A40-ER20-115	○	40	35	35	115	LN20S	-	ER20	SGC120200	
A40-ER25-115	●	40	42	35	115	LN25	WER25	ER25	SGC160200	
A40-ER32-120	●	40	50	40	120	LN32	WER32	ER32	SGD220250	
A50-ER25-125	○	50	42	35	125	LN25	WER25	ER25	SGC160200	
A50-ER32-130	○	50	50	40	130	LN32	WER32	ER32	SGD220250	
A50-ER40-130	○	50	63	40	130	LN40	WER40	ER40	SGD280250	

订货示例: A32-ER16-100

● 常备库存 Unallocated stock ● 可备库存 Available stock ○ 订单生产 Order production

工具系统
热胀工具系统 SHRINK FIT HOLDER
HSK工具系统 HSK TOOL SYSTEM
TMG21工具系统 TMG21 TOOL SYSTEM
7:24工具系统 7:24 TOOL SYSTEM
其它工具系统 SPECIAL TOOL SYSTEM
附件 ACCESSORIES

D 工具系统 Tool System

有扁尾莫氏圆锥孔变径套
Morse Taper Shank with Tang

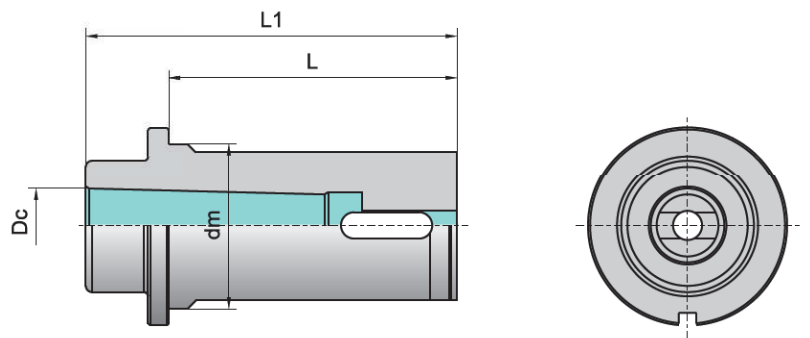

型号 Type	库存 Stock	莫氏锥度 Morse taper	尺寸(mm) Dimension				安装钻头直径 Drill bit dia.	重量 (kg)
			dm	Dc	L	L1		
RS32-M2	●	MT2	32	17.78	70	90	14.25-23	
RS40-M2	●	MT2	40	17.78	70	90	14.25-23	
RS40-M3	●	MT3	40	23.825	70	110	23.25-31.75	
RS50-M2	●	MT2	50	17.78	120	125	14.25-23	
RS50-M3	●	MT3	50	23.825	120	125	23.25-31.75	
RS50-M4	●	MT4	50	31.267	120	135	32-50.5	
RS63-M2	●	MT2	63	17.78	125	130	14.25-23	
RS63-M3	●	MT3	63	23.825	125	130	23.25-31.75	
RS63-M4	●	MT4	63	31.267	125	135	32-50.5	
RS63-M5	●	MT5	63	44.399	125	170	51-76	

订货示例: RS32-M2

常备库存 Unallocated stock
 可备库存 Available stock
 订单生产 Order production

D 工具系统 Tool System

SK卡簧 SK Collet

SK卡簧编号规则:

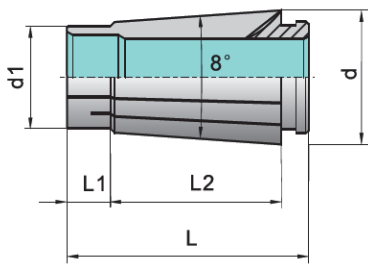
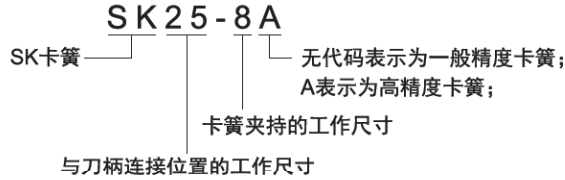

外形尺寸

型号 Type	尺寸(mm) Dimension				
	d	d1	L	L1	L2
SK06	10.4	7.5	25	3.8	17.4
SK10	15.5	12	30.5	5	21.3
SK16	24.6	18.8	45	8	32
SK25	35.6	28.9	57	8.5	43

夹持精度

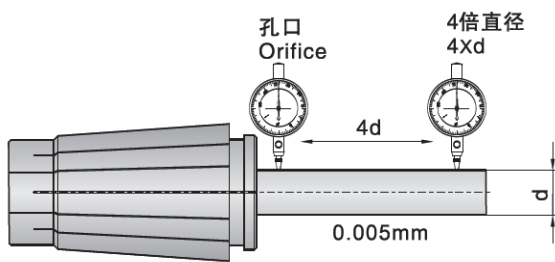

夹持直径 Chuckling dia.	径向跳动 Run out		
	一般精度 General precision	高精度A High precision	精密级P Ultrahigh precision
1.0~1.4	0.01	0.005	0.003
1.5~2.9	0.01	0.005	0.003
3.0~5.9	0.01	0.005	0.003
6.0~9.9	0.01	0.005	0.003
10.0~17.9	0.01	0.005	0.003
18.0~26.9	0.01	0.005	0.003

名称 Name	型号 Type	夹持直径 Holding dia.
SK06	SK06-2	1.8~2.0
	-3	2.8~3.0
	-4	3.5~4.0
	-5	4.5~5.0
	-6	5.5~6.0
SK10	SK10-2	1.75~2.0
	-3	2.75~3.0
	-4	3.5~4.0
	-5	4.5~5.0
	-6	5.5~6.0
	-8	7.5~8.0
-9	8.5~9.0	
-10	9.5~10.0	

名称 Name	型号 Type	夹持直径 Holding dia.
SK16	SK16-3	2.75~3.0
	-4	3.5~4.0
	-5	4.5~5.0
	-6	5.5~6.0
	-8	7.5~8.0
	-9	8.5~9.0
	-10	9.5~10.0
	-12	11.5~12.0
	-14	13.5~14.0
	-15	14.5~15.0
-16	15.5~16.0	

名称 Name	型号 Type	夹持直径 Holding dia.
SK25	SK25-6	5.5~6.0
	-8	7.5~8.0
	-10	9.5~10.0
	-12	11.5~12.0
	-16	15.5~16.0
	-18	17.5~18.0
	-20	19.5~20.0
	-21	20.5~21.0
	-22	21.5~22.0
	-24	23.5~24.0
-25	24.5~25.0	

订货示例: SK16-4; SK25-10A

工具系统
热胀工具系统
HSK工具系统
TMG21工具系统
7:24工具系统
其它工具系统
附件

D 工具系统 Tool System

ER卡簧 ER Collet

ER卡簧编号规则:

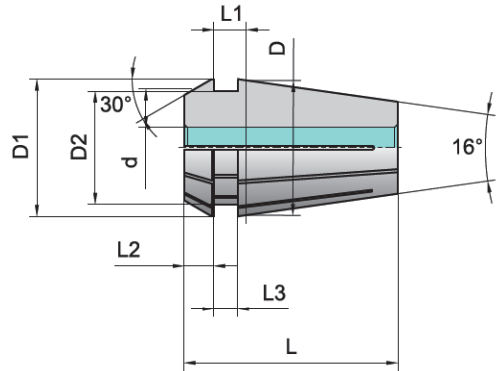
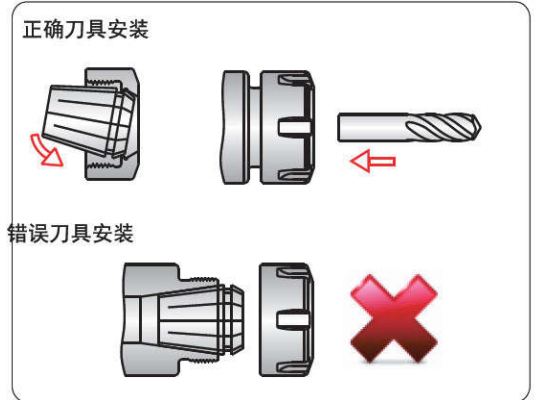
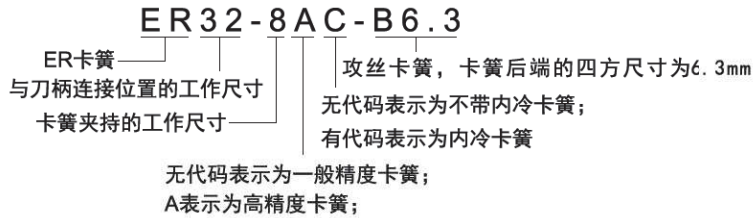

外形尺寸

型号 Type	d	D	D1	D2	L	L1	L2	L3	弹性收缩量 Collapsible capacity
ER11	1.0-7.0	11	11.5	9.5	18	3.8	2.5	2	0.5
ER16	1.0-2.5	16	17	13.8	27.5	6.26	4	2.7	0.5
	>2.5-10.0	16	17	13.8	27.5	6.26	4	2.7	1
ER20	1.0-2.5	20	21	17.4	31.5	6.36	4.8	2.8	0.5
	>2.5-13.0	20	21	17.4	31.5	6.36	4.8	2.8	1
ER25	1.0-2.5	25	26	22	34	6.66	5	3.1	0.5
	>2.5-16.0	25	26	22	34	6.66	5	3.1	1
ER32	2.0-2.5	32	33	29.2	40	7.16	5.5	3.6	0.5
	>2.5-10.0	32	33	29.2	40	7.16	5.5	3.6	1
ER40	3.0-26.0	40	41	36.2	46	7.66	7	4.1	1
ER50	6.0-10.0	50	52	46	60	12.6	8.5	5.5	1
	>10.0-34.0	50	52	46	60	12.6	8.5	5.5	2

ER卡簧(无内冷) ER Collet Without Cooling

夹持精度

夹持直径 Chucking dia.	径向跳动 Run out		
	一般精度 General precision	高精度A High precision	精密级P Ultrahigh precision
1.0~1.4	0.015	0.01	0.005
1.5~2.9	0.015	0.01	0.005
3.0~5.9	0.015	0.01	0.005
6.0~9.9	0.015	0.01	0.005
10.0~17.9	0.02	0.01	0.005
18.0~26.9	0.02	0.01	0.005
27.0~34.0	0.02	0.01	0.005

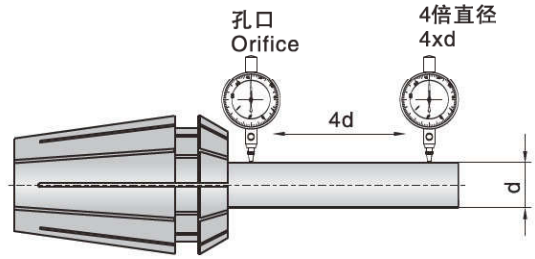

ER11-*		ER16-*		ER20-*		ER25-*		ER32-*		ER40-*	
型号 Type	夹持范围 Range	型号 Type	夹持范围 Range	型号 Type	夹持范围 Range	型号 Type	夹持范围 Range	型号 Type	夹持范围 Range	型号 Type	夹持范围 Range
ER11-1	1-0.5	ER16-1	1-0.5	ER20-1	1-0.5	ER25-2	2-1.5	ER32-3	3-2	ER40-3	3-2
ER11-2	2-1.5	ER16-2	2-1.5	ER20-2	2-1.5	ER25-3	3-2	ER32-4	4-3	ER40-4	4-3
ER11-3	3-2.5	ER16-3	3-2	ER20-3	3-2	ER25-4	4-3	ER32-5	5-4	ER40-5	5-4
ER11-4	4-3.5	ER16-4	4-3	ER20-4	4-3	ER25-5	5-4	ER32-6	6-5	ER40-6	6-5
ER11-5	5-4.5	ER16-5	5-4	ER20-5	5-4	ER25-6	6-5	ER32-8	8-7	ER40-8	8-7
ER11-6	6-5.5	ER16-6	6-5	ER20-6	6-5	ER25-8	8-7	ER32-9	9-8	ER40-9	9-8
ER11-7	7-6.5	ER16-8	8-7	ER20-8	8-7	ER25-9	9-8	ER32-10	10-9	ER40-10	10-9
		ER16-9	9-8	ER20-9	9-8	ER25-10	10-9	ER32-12	12-11	ER40-12	12-11
		ER16-10	10-9	ER20-10	10-9	ER25-12	12-11	ER32-14	14-13	ER40-14	14-13
				ER20-12	12-11	ER25-14	14-13	ER32-15	15-14	ER40-15	15-14
						ER25-15	15-14	ER32-16	16-15	ER40-16	16-15
						ER25-16	16-15	ER32-18	18-17	ER40-18	18-17
								ER32-20	20-19	ER40-20	20-19
										ER40-21	21-20
										ER40-22	22-21
										ER40-24	24-23
										ER40-25	25-24
										ER40-26	26-25

订货示例: ER16-4;ER25-10A

D 工具系统 Tool System

ER卡簧(内冷式) ER Collet with Cooling

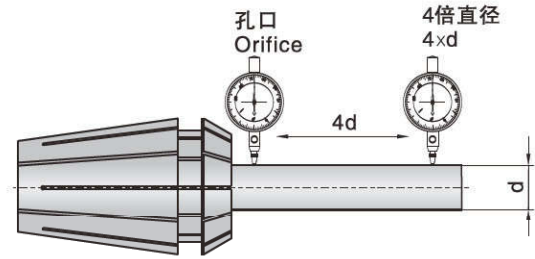
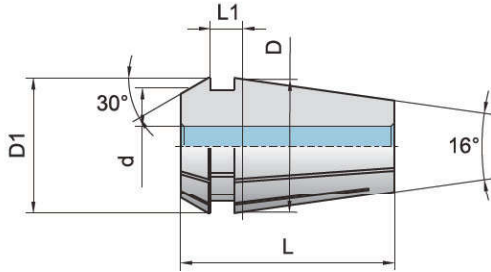

夹持精度

型号 Type	d	夹持范围 Range	D	D1	L	L1
ER11-*C	3~7	0.1	11	11.5	18	3.8
ER16-*C	3~6	0.1	16	17	27.5	6.26
	6~10	0.5	16	17	27.5	6.26
ER20-*C	3~6	0.1	20	21	31.5	6.36
	6~13	0.5	20	21	31.5	6.36
ER25-*C	3~6	0.1	25	26	34	6.66
	6~16	0.5	25	26	34	6.66
ER32-*C	3~8	0.1	32	33	40	7.16
	8~20	0.5	32	33	40	7.16
ER40-*C	4~10	0.1	40	41	46	7.66
	10~26	0.5	40	41	46	7.66

夹持直径 Chuckling dia.	径向跳动 Run out		
	一般精度 General precision	高精度A High precision	精密级P Ultrahigh precision
1.0~1.4	0.015	0.01	0.005
1.5~2.9	0.015	0.01	0.005
3.0~5.9	0.015	0.01	0.005
6.0~9.9	0.015	0.01	0.005
10.0~17.9	0.02	0.01	0.005
18.0~26.9	0.02	0.01	0.005
27.0~34.0	0.02	0.01	0.005

ER11-*C		ER16-*C		ER20-*C		ER25-*C		ER32-*C		ER40-*C	
型号 Type	夹持范围 Range	型号 Type	夹持范围 Range	型号 Type	夹持范围 Range	型号 Type	夹持范围 Range	型号 Type	夹持范围 Range	型号 Type	夹持范围 Range
3C	3-2.9	3C	3-2.9	3C	3-2.9	3C	3-2.9	3C	3-2.9	4C	4-3.9
4C	4-3.9	4C	4-3.9	4C	4-3.9	4C	4-3.9	4C	4-3.9	5C	5-4.9
5C	5-4.9	5C	5-4.9	5C	5-4.9	5C	5-4.9	5C	5-4.9	6C	6-5.9
6C	6-5.9	6C	6-5.5	6C	6-5.5	6C	6-5.5	6C	6-5.9	8C	8-7.9
		8C	8-7.5	8C	8-7.5	8C	8-7.5	8C	8-7.5	9C	9-8.9
		9C	9-8.5	9C	9-8.5	9C	9-8.5	9C	9-8.5	10C	10-9.5
		10C	10-9.5	10C	10-9.5	10C	10-9.5	10C	10-9.5	12C	12-11.5
				12C	12-11.5	12C	12-11.5	12C	12-11.5	14C	14-13.5
						14C	14-13.5	14C	14-13.5	15C	15-14.5
						15C	15-14.5	15C	15-14.5	16C	16-15.5
						16C	16-15.5	16C	16-15.5	18C	18-17.5
								18C	18-17.5	20C	20-19.5
								20C	20-19.5	21C	21-20.5
										22C	22-21.5
										24C	24-23.5
										25C	25-24.5
										26C	26-25.5

订货示例: ER25-10C

D 工具系统 Tool System

攻丝卡簧 Tapping Collet

型号 Type						d	W	L	丝锥标准 TAP Standard	
ER16	ER20	ER25	ER32	ER40	ER50				ISO	JIS
ER16-2.24-B1.8	ER20-2.24-B1.8	ER25-2.24-B1.8	ER32-2.24-B1.8	ER40-2.24-B1.8	-	2.24	1.8	15	M3	
ER16-2.5-B2	ER20-2.5-B2	ER25-2.5-B2	ER32-2.5-B2	ER40-2.5-B2	-	2.5	2		M3.5	
ER16-3-B2.5	ER20-3-B2.5	ER25-3-B2.5	ER32-3-B2.5	ER40-3-B2.5	-	3	2.5	18		M2
ER16-3.15-B2.5	ER20-3.15-B2.5	ER25-3.15-B2.5	ER32-3.15-B2.5	ER40-3.15-B2.5	-	3.15	2.5		M3,M4	
ER16-3.55-B2.8	ER20-3.55-B2.8	ER25-3.55-B2.8	ER32-3.55-B2.8	ER40-3.55-B2.8	-	3.55	2.8	M3.5,M4.5		
ER16-4-B3.1	ER20-4-B3.1	ER25-4-B3.1	ER32-4-B3.1	ER40-4-B3.1	-	4	3.1		M3	
ER16-4-B3.15	ER20-4-B3.15	ER25-4-B3.15	ER32-4-B3.15	ER40-4-B3.15	-	4	3.15	M4,M5		
ER16-4.5-B3.55	ER20-4.5-B3.55	ER25-4.5-B3.55	ER32-4.5-B3.55	ER40-4.5-B3.55	-	4.5	3.55	M6		
ER16-5-B4	ER20-5-B4	ER25-5-B4	ER32-5-B4	ER40-5-B4	-	5	4	M5	M4,M4.5	
ER16-5.5-B4.5	ER20-5.5-B4.5	ER25-5.5-B4.5	ER32-5.5-B4.5	ER40-5.5-B4.5	-	5.5	4.5		M5,M5.5	
ER16-6-B4.5	ER20-6-B4.5	ER25-6-B4.5	ER32-6-B4.5	ER40-6-B4.5	ER50-6-B4.5	6	4.5		M6	
ER16-6.2-B5	ER20-6.2-B5	ER25-6.2-B5	ER32-6.2-B5	ER40-6.2-B5	ER50-6.2-B5	6.2	5		M7,M8	
ER16-6.3-B5	ER20-6.3-B5	ER25-6.3-B5	ER32-6.3-B5	ER40-6.3-B5	ER50-6.3-B5	6.3	5	M6,M8		
ER16-7-B5.5	ER20-7-B5.5	ER25-7-B5.5	ER32-7-B5.5	ER40-7-B5.5	ER50-7-B5.5	7	5.5		M9,M10	
ER16-8-B6	ER20-8-B6	ER25-8-B6	ER32-8-B6	ER40-8-B6	ER50-8-B6	8	6	22		M11
ER16-8-B6.3	ER20-8-B6.3	ER25-8-B6.3	ER32-8-B6.3	ER40-8-B6.3	ER50-8-B6.3	8	6.3		M8,M10	
ER16-8.5-B6.5	ER20-8.5-B6.5	ER25-8.5-B6.5	ER32-8.5-B6.5	ER40-8.5-B6.5	ER50-8.5-B6.5	8.5	6.5		M12	
ER16-9-B7.1	ER20-9-B7.1	ER25-9-B7.1	ER32-9-B7.1	ER40-9-B7.1	ER50-9-B7.1	9	7.1	M12		
ER16-10-B8	ER20-10-B8	ER25-10-B8	ER32-10-B8	ER40-10-B8	ER50-10-B8	10	8	25	M10	
	ER20-10.5-B8	ER25-10.5-B8	ER32-10.5-B8	ER40-10.5-B8	ER50-10.5-B8	10.5	8			M14,M15
	ER20-11.2-B9	ER25-11.2-B9	ER32-11.2-B9	ER40-11.2-B9	ER50-11.2-B9	11.2	9	M14		
	ER20-12.5-B10	ER25-12.5-B10	ER32-12.5-B10	ER40-12.5-B10	ER50-12.5-B10	12.5	10	M16	M16	
	ER20-13-B10	ER25-13-B10	ER32-13-B10	ER40-13-B10	ER50-13-B10	13	10		M17	
		ER25-14-B11	ER32-14-B11	ER40-14-B11	ER50-14-B11	14	11	28		M18
		ER25-14-B11.2	ER32-14-B11.2	ER40-14-B11.2	ER50-14-B11.2	14	11.2		M18,M20	
		ER25-15-B12	ER32-15-B12	ER40-15-B12	ER50-15-B12	15	12		M20	
		ER25-16-B12.5	ER32-16-B12.5	ER40-16-B12.5	ER50-16-B12.5	16	12.5	M22		
			ER32-17-B13	ER40-17-B13	ER50-17-B13	17	13		M22	
			ER32-18-B14	ER40-18-B14	ER50-18-B14	18	14	33	M24	
			ER32-19-B15	ER40-19-B15	ER50-19-B15	19	15			M24,M25
			ER32-20-B15	ER40-20-B15	-	20	15		M26,M27	
				ER50-20-B15		20	15	40		M26,M27
				ER50-21-B17		21	17			M28
				ER50-22.4-B18		22.4	18	M33		
				ER50-23-B17		23	17		M30	
				ER50-25-B19		25	19		M33	
				ER50-25-B20		25	20	M36		
				ER50-28-B21		28	21		M36	

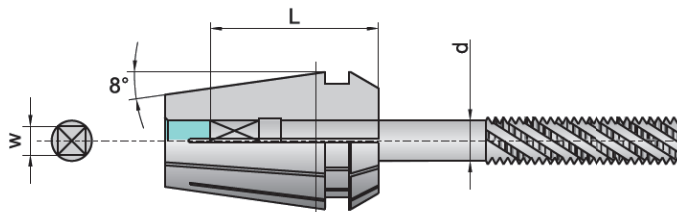

订货示例: ER25-10-B8

D 工具系统 Tool System

液压卡簧 Hydraulic Collet

液压刀柄卡簧编号规则:

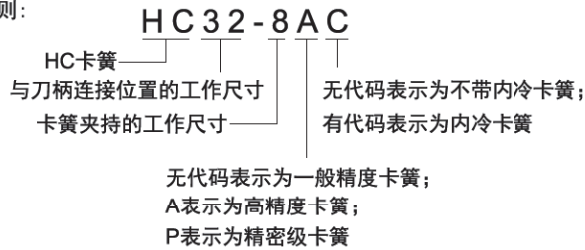

夹持精度

夹持直径 Chuckling dia.	径向跳动 Run out		
	一般精度 General precision	高精度A High precision	精密级P Ultraprecision
<10	0.01	0.005	0.003
10~20	0.01	0.005	0.003
>20	0.01	0.005	0.003

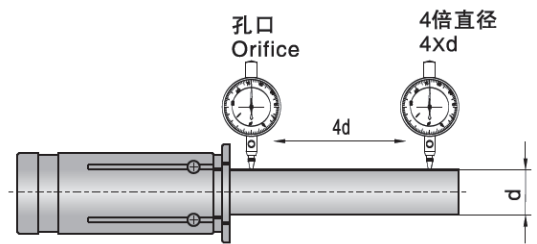

液压卡簧(无内冷) Hydraulic Collet without Cooling

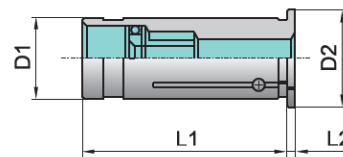

普通卡簧 Simple collet	夹持范围 Holding range	尺寸(mm) Dimension			
		D1	D2	L1	L2
HC12-*	3,4,5,6,7,8	12	16	45	2
HC20-*	3,4,5,6,7,8,9,10,11,12,13,14,15,16	20	24	50.5	2
HC32-*	6,8,10,12,14,16,18,20,25	32	36	60.5	3

订货示例: HC32-10 :

液压卡簧(有内冷) Hydraulic Collet with Cooling

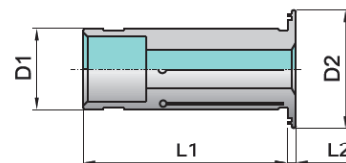

内冷卡簧 Coolant collet	夹持范围 Holding range	尺寸(mm) Dimension			
		D1	D2	L1	L2
HC12-*C	3,4,5,6,8	12	19	45	2
HC20-*C	3,4,5,6,8,9,10,12,14,15,16	20	29	50.5	2
HC32-*C	8,10,12,14,16,18,20,25	32	39	60.5	3

订货示例: HC20-6C

D 工具系统 Tool System

强力夹头刀柄卡簧 Power Chuck Collet

强力夹头刀柄卡簧编号规则:

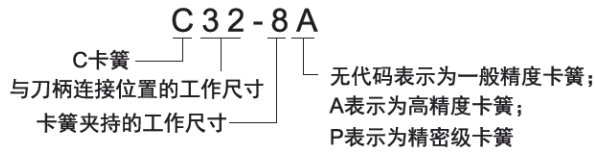

夹持精度

夹持直径 Chucking dia.	径向跳动 Run out		
	一般精度 General precision	高精度A High precision	精密级P Ultrahigh precision
<10	0.01	0.005	-
10~20	0.01	0.005	-
>20	0.01	0.005	-

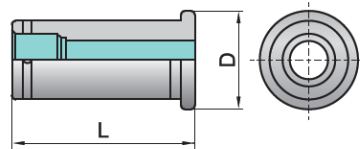
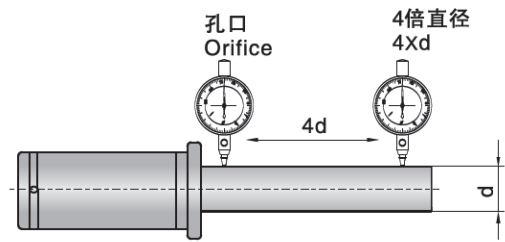

卡簧 Collet	夹持范围 Hold size 公制 Metric	尺寸(mm) Dimension		重量 (kg)
		D	L	
C20-*	6,8,10,12,16	26	55.1	
C25-*	6,8,10,12,16,20	30	63	
C32-*	4,5,6,8,10,12,14,16,18,20,25	38	70	
C42-*	6,8,10,12,16,20,25,32	48	75	

订货示例: C32-10; C25-6A; C25-6P

工具系统
热胀工具系统
SHRINK FIT HOLDER
HSK工具系统
HSK TOOL SYSTEM
TMG21工具系统
TMG21 TOOL SYSTEM
7:24工具系统
7:24 TOOL SYSTEM
其它工具系统
SPECIAL TOOL SYSTEM
附件
ACCESSORIES

D 工具系统 Tool System

GSK高速螺母 GSK Clamping Nut

高速无槽GSK螺母
High speed slotless GSK nut

内形精密加工完成，精度更稳定
Precision machining, more stable accuracy

表面光滑设计，手感舒适，外型更美观
Smooth surface, comfortable feel, beautiful appearance

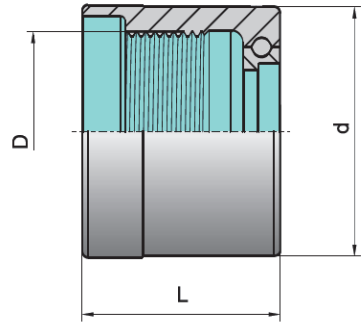

型号 Designation	尺寸 Dimension(mm)			卡簧 Collet
	D	d	L	
LN-GSK06	M15.5x1	19.5	21.3	SK06
LN-GSK10	M22x1	27.1	25	SK10
LN-GSK16	M32x1.5	40	32	SK16
LN-GSK25	M45x1.5	55	37.5	SK25

GSK扳手 GSK Wrench

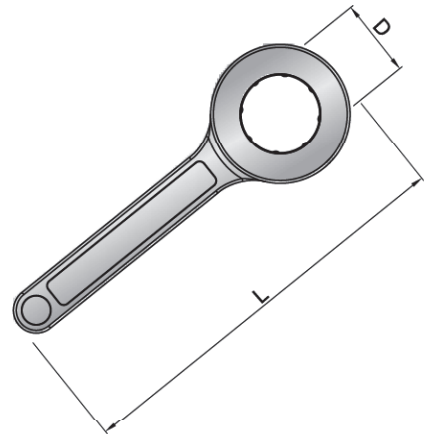

型号 Designation	尺寸 Dimension(mm)	
	D	L
WGSK06	19.5	120
WGSK10	27.1	135
WGSK16	40	180
WGSK25	55	250

D 工具系统 Tool System

GSER螺母
GSER Nut

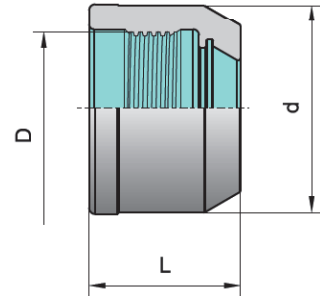

型号 Specification	尺寸(mm) Dimension			卡簧 Collet
	D	d	L	
LN-GSER16	M22x1.5	30	24.7	ER16
LN-GSER20	M25x1.5	35	25.5	ER20
LN-GSER25	M32x1.5	40	25.9	ER25
LN-GSER32	M40x1.5	48	26.6	ER32

GSER扳手 GSER Wrench

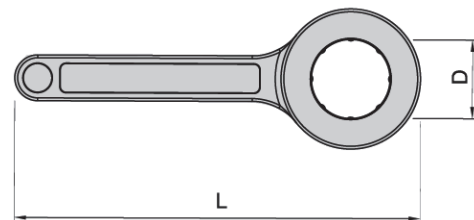

型号 Specification	尺寸(mm) Dimension	
	D	L
WGSER16	30	120
WGSER20	35	135
WGSER25	40	180
WGSER32	48	300

D 工具系统 Tool System

BT测试棒
BT Test Rod

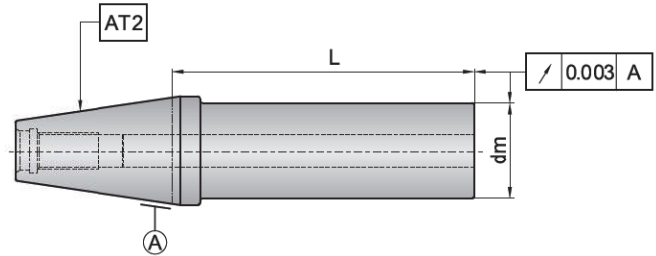

型号 Type	库存 Stock	锥柄型式 Taper type	尺寸(mm) Dimension		重量 (kg)
			dm	L	
BT30-TSB32-250	●	BT30	32	250	1.60
BT40-TSB40-300	●	BT40	40	300	3.10
BT50-TSB50-350	●	BT50	50	350	6.48

JT测试棒
JT Test Rod

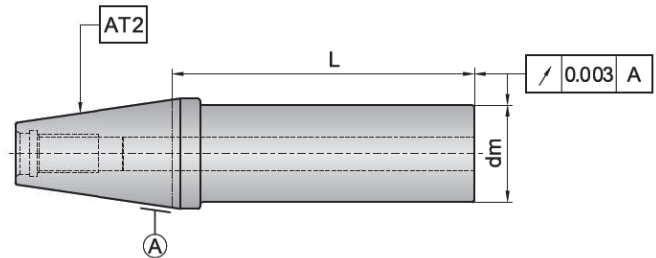

型号 Type	库存 Stock	锥柄型式 Taper type	尺寸(mm) Dimension		重量 (kg)
			dm	L	
JT40-TSB40-300	●	JT40	40	300	3.12
JT50-TSB50-350	●	JT50	50	350	6.47

订货示例: JT50-TSB50-350

● 常备库存 Unallocated stock ● 可备库存 Available stock ○ 订单生产 Order production

工具系统

SHRINK FIT HOLDER
热胀工具系统

HSK TOOL SYSTEM
HSK工具系统

TMG21 TOOL SYSTEM
TMG21工具系统

7:24 TOOL SYSTEM
7:24工具系统

SPECIAL TOOL SYSTEM
其它工具系统

ACCESSORIES
附件

D 工具系统 Tool System

ER螺母

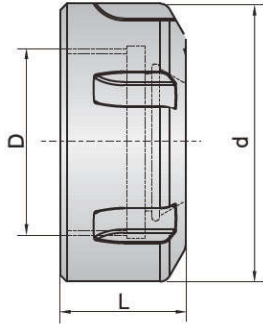

型号 Type	尺寸 (mm) Dimension			
	D	d	L	适用卡簧 Apply for
LN11S	M14X0.75	19	11.3	ER11
LN16S	M22X1.5	28	17.5	ER16
LN20S	M25X1.5	34	19.0	ER20
LN16	M22X1.5	32	17.5	ER16
LN20	M25X1.5	35	19.0	ER20
LN25	M32X1.5	42	20.0	ER25
LN32	M40X1.5	50	22.5	ER32
LN40	M50X1.5	63	25.5	ER40
LN11M	M13X0.75	16	11.3	ER11
LN16M	M19X0.75	22	17.5	ER16
LN20M	M24X1.0	28	19	ER20

外锥端螺钉

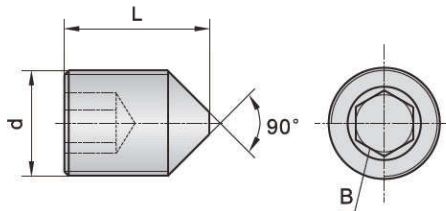

型号 Type	尺寸 (mm) Dimension			
	d	螺距 Pitch	L	B
21A.25-E1	M6	0.75	8.5	S3
21A.32-E1	M8	1.0	11.0	S4
21A.40-E1	M10	1.25	14.0	S5
21A.50-E1	M12	1.5	16.5	S6
21A.63-E1	M16	2.0	20.5	S8
21A.80-E1	M20	2.5	26.0	S10
21A.100-E1	M24	3.0	27.5	S12
21A.125-E1	M30	3.0	37.0	S14

内锥端螺钉

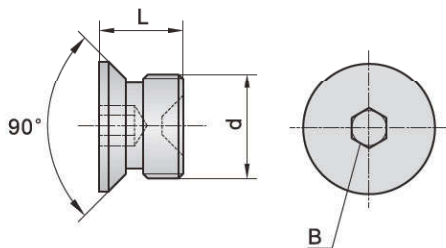

型号 Type	尺寸 (mm) Dimension			
	d	螺距 Pitch	L	B
21A.25-E2	M6	0.75	5.0	S2
21A.32-E2	M8	1.0	6.5	S2
21A.40-E2	M10	1.25	8.0	S3
21A.50-E2	M12	1.5	8.5	S4
21A.63-E2	M16	2.0	12.0	S5
21A.80-E2	M20	2.5	13.8	S6
21A.100-E2	M24	3.0	18.5	S8
21A.125-E2	M30	3.0	23.0	S10

D 工具系统 Tool System

滑销

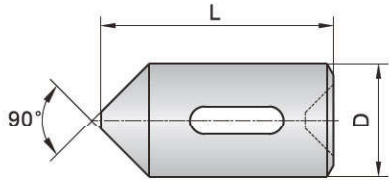

型号 Type

尺寸 (mm) Dimension

D

L

21A.25-E3

7

12.0

21A.32-E3

9

14.5

21A.40-E3

11

18.5

21A.50-E3

13

26.5

21A.63-E3

17

32.0

21A.80-E3

21

43.0

21A.100-E3

25

52.0

21A.125-E3

32

63.0

工具系统

SHRINK FIT HOLDER
热胀工具系统

HSK TOOL SYSTEM
HSK工具系统

TMG21 TOOL SYSTEM
TMG21工具系统

7:24 TOOL SYSTEM
7:24工具系统

SPECIAL TOOL SYSTEM
其它工具系统

ACCESSORIES
附件

定位销

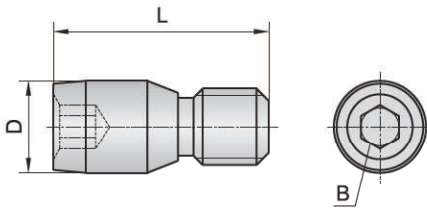

型号 Type

尺寸(mm) Dimension

D

L

B

21A.25-E4

3.0

8

S1.5

21A.32-E4

4.7

11

S1.5

21A.40-E4

5.7

12

S2.0

21A.50-E4

6.5

14

S2.5

21A.63-E4

9.5

20

S4.0

21A.80-E4

11.5

23

S5.0

21A.100-E4

15.5

30

S8.0

21A.125-E4

19.5

40

S8.0